

SIEMENS



Ultrasonic Controllers

HydroRanger 200 HMI

Operating Instructions

Edition

08/2015

Safety Guidelines: Warning notices must be observed to ensure personal safety as well as that of others, and to protect the product and the connected equipment. These warning notices are accompanied by a clarification of the level of caution to be observed.

Qualified Personnel: This device/system may only be set up and operated in conjunction with this manual. Qualified personnel are only authorized to install and operate this equipment in accordance with established safety practices and standards.

Unit Repair and Excluded Liability:

- The user is responsible for all changes and repairs made to the device by the user or the user's agent.
- All new components are to be provided by Siemens.
- Restrict repair to faulty components only.
- Do not reuse faulty components.

Warning: Cardboard shipping package provides limited humidity and moisture protection. This product can only function properly and safely if it is correctly transported, stored, installed, set up, operated, and maintained.

This product is intended for use in industrial areas. Operation of this equipment in a residential area may cause interference to several frequency based communications.

Note: Always use product in accordance with specifications.

Copyright Siemens AG 2015. All Rights Reserved

Disclaimer of Liability

This document is available in bound version and in electronic version. We encourage users to purchase authorized bound manuals, or to view electronic versions as designed and authored by Siemens. Siemens will not be responsible for the contents of partial or whole reproductions of either bound or electronic versions.

While we have verified the contents of this manual for agreement with the instrumentation described, variations remain possible. Thus we cannot guarantee full agreement. The contents of this manual are regularly reviewed and corrections are included in subsequent editions. We welcome all suggestions for improvement.

Technical data subject to change.

Contact Siemens Technical Publications at the following address:

Technical Publications
Siemens Canada Limited
PD PA PI LW
1954 Technology Drive, P.O. Box 4225
Peterborough, Ontario, Canada, K9J 7B1
Email: techpubs.smpi@siemens.com

European Authorized Representative

Siemens AG
Industry Sector
76181 Karlsruhe
Deutschland

- For a selection of Siemens level measurement manuals, go to: **www.siemens.com/processautomation**. Under Process Instrumentation, select *Level Measurement* and then go to the manual archive listed under the product family.
- For a selection of Siemens weighing manuals, go to: **www.siemens.com/processautomation**. Under Weighing Technology, select *Continuous Weighing Systems* and then go to the manual archive listed under the product family.

Table of contents

Introduction	1
The Manual	1
Manual symbols	1
Application examples	2
Firmware revision history	2
Sensor node	2
HMI	2
Safety notes	3
Safety marking symbols	3
FCC Conformity	4
CE Electromagnetic Compatibility (EMC) Conformity	4
Description	7
Overview	7
Features	7
Applications	8
Approvals and certificates	8
Installing and mounting	9
Mounting locations	10
Mounting instructions	11
Wall mount.....	11
Cable routed through a conduit.....	12
.....	12
Cable exposed and entering through the cable glands.....	13
Panel mount.....	14
Mounting the enclosure	15
HydroRanger 200 HMI wiring compartment	16
Replacing the battery	17
Installing the SmartLinX® communications card	18
Connecting	19
Terminal board	20
Cables	21
Transducers	21
Relays	22
Temperature sensor	22
mA Input	23
mA Output	23
Level system synchronization	23
Power	24
Digital communications	24
RS-232 serial connection	25
RS-485 serial connection	25
Discrete inputs	25
Commissioning	27
Local commissioning	27

Activating the HydroRanger 200 HMI	27
RUN Mode	27
Measurement Views in RUN mode	28
The LCD Display	28
Measurement Mode Display: Normal operation	
Auxiliary Reading	29
Multiple readings	30
PROGRAM Mode	31
Key functions in Measurement mode	31
Programming the HydroRanger 200 HMI	31
Parameter menus	31
Quick Start Wizards	35
Setting wizards via graphical display	35
Application examples	58
Level application	58
Flow application	59
General operation	61
Single-point models	62
Average or differential	62
Dual-point models	63
Average or differential	63
Measurement conditions	63
Response rate	64
Dimensions	64
Fail-safe indexes	64
Relays	65
General introduction	65
Relay functions	65
Alarm	65
Pump	66
Totalizing and Sampling	66
Relay status – Navigation View	67
Relay-related parameters	67
Relay wiring test	68
Relay activation	68
Preset applications	69
Relay fail-safe	70
Security	70
Parameter types	70
Display readout	71
Adjusting the Primary Reading:	71
Backup level override	72
Backup level override parameters	72
Discrete inputs	73
Wiring the discrete inputs	73
Adjusting the discrete input logic	73
mA I/O	74

mA Input	74
mA Output	74
Volume	76
Readings	76
Vessel shape and dimensions	76
Characterization chart	77
.....	78
Alarms	79
Level	79
Setting simple level alarms	80
Rate	80
In-bounds/Out-of-bounds Range	80
Cable fault	81
Temperature	81
Loss of Echo (LOE)	82
Pump control	83
Setting a Pump Down Group	83
Setting a Pump Up (Reservoir) Group	84
Other pump control algorithms	86
Set relays to Alternate Duty Backup	86
Set relays to Fixed Duty Assist	86
Set relays to Fixed Duty Backup	87
Set relays to Service Ratio Duty Assist	87
Set relays to First In First Out	88
Optional pump controls	89
Starting pumps by rate of level change	89
Rotating pumps by service ratio	90
Totalizing pumped volume	91
Setting independent fail-safe controls	92
Setting a pump to Run-ON	92
Setting the pump start delays	93
Reducing wall cling	93
Grouping pumps	94
Setting a flush valve	94
Relay controlled by communications	95
Tracking pump usage	95
Rake (Screen) control	96
Setting a rake control	96
Setting common parameters	97
Set Relay 1 (Operate Rake)	97
Set Relays 2 to 4 (Level Alarms)	97
External totalizers and flow samplers	98
Relay contacts	98
Totalizer	98
Flow sampler	99
Based on volume and time	99
Open Channel Monitoring (OCM)	100
Common parameters	100

Setting Zero Head	101
Setting totalized volume	103
Applications supported by HydroRanger 200 HMI	103
BS-3680 / ISO 1438/1 Thin Plate V-Notch weir	103
BS-3680 / ISO 4359 Rectangular Flume	104
Palmer-Bowlus Flume	105
H-Flume	106
PMDs with exponential flow to Head Function	107
Applicable weir profiles	107
Non-applicable weir profiles	108
Parshall Flume	109
Leopold Lagco Flume	110
Cut Throat Flume	111
Universal calculation support	112
Typical flow characterization	112
Example flumes	113
Example weirs	113
Configuration testing	115
I/O Checkout	115
Application test	115
Parameters	117
Key terms	117
Parameter indexing	118
Index selector examples	119
Sensor and measurement	119
Calibration	120
Pumps	120
High level alarm	120
Index types	121
Alphabetical list	206
Service and maintenance	215
Firmware updates	215
Decontamination declaration	215
Troubleshooting	217
Communication troubleshooting	217
General fault codes	218
Common problems chart	219
Noise problems	226
Determine the noise source	226
Non-transducer noise sources	227
Avoiding common wiring problems	227
Reducing electrical noise	227
Reducing acoustical noise	227
Measurement difficulties	228
Loss of Echo (LOE)	228
Adjust transducer aiming	228
Increase fail-safe timer value	228
Install a transducer with a narrower beam	228
Fixed reading	229

Obstructions in the sound beam	229
Nozzle mountings	229
Set the HydroRanger 200 HMI to ignore the bad echo	229
Wrong reading	230
Types of wrong readings	230
Liquid splashing	230
Adjust the Echo Algorithm	230
Transducer ringing	230
Unit repair and excluded liability	231
Technical data	233
Appendix A: Technical reference	239
Transmit pulse	239
Echo processing	239
TVT (Time Varying Threshold) curves	240
Auto False Echo Suppression	240
Algorithm	241
Distance calculation	241
Sound Velocity	242
Scanning	243
Volume calculation	243
Universal Curved	244
Flow calculation	244
Universal Linear	245
Universal Curved	245
Response Rate	246
Analog Output	246
Current Output Function	246
Loss of Echo (LOE)	247
Fail-safe Mode	247
Appendix B: Pump control reference	248
Pump control options	248
Pump groups	248
Pump by rate	248
Pump control algorithms	248
Fixed Duty Assist	249
Fixed Duty Backup	249
Alternate Duty Assist	250
Alternate Duty Backup	250
Service Ratio Duty Assist	251
Service Ratio Duty Backup	252
First In First Out	252
Pump by Rate	252
Other pump controls	252
Appendix C: Communications	253
HydroRanger 200 HMI communication systems	253
Optional SmartLinX® Cards	253
Communication systems	253
Communication ports	254
Modbus	254

SmartLinX®	254
Communications installation	255
Wiring guidelines	255
Configuring communications ports (parameters)	257
SIMATIC Process Device Manager (PDM)	258
Device description	258
Modbus register map	259
Word order (R40,062)	260
Map ID (R40,063)	260
Product ID (R40,064)	261
Point data (R41,010 – R41,031)	261
Totalizer (R41,040 – R41,043)	261
Input/Output (R41,070 – R41,143)	261
Discrete inputs (R41,070)	262
Relay outputs (R41,080)	262
mA Input (R41,090)	262
mA Output (R41,110-41,111)	262
Pump control (R41,400 – R41,474)	262
Pump ON setpoint (R41,420 – R41,425)	262
Pump OFF setpoint (R41,430 – R41,435)	262
Pumped volume (R41,440 – R41,443)	263
Pump hours (R41,450 – R41,461)	263
Pump starts (R41,470 – R41,475)	263
Parameter access (R43,998 – R46,999)	263
Parameter indexing	264
Indexing the parameter access area	264
Reading parameters	264
Global index method.....	264
Parameter-specific index method.....	265
Writing parameters	265
Global index method.....	266
Parameter-specific index method.....	266
Format words (R46,000 to R46,999)	266
Global index method.....	266
Parameter-specific index method.....	266
Format registers	266
Data types	268
Numeric values	268
Bit values	268
Unsigned double precision integer (UINT32)	268
Split values	269
Text messages	270
Relay function codes (<i>2.8.1.4. Relay Function Only</i>)	271
Error handling	272
Modbus responses	272
Error handling	272
Communication troubleshooting	273
General	273

Specific	273
Single Parameter Access (SPA)	274
Mapping	274
Reading parameters	274
Writing parameters	275
Format register	275
Error codes	276
Appendix D: Updating software	277
Appendix E: Upgrading	278
Mounting a HydroRanger 200 HMI	278
Connecting the transducer	278
Co-axial transducer extension	278
Connecting a transducer with RG62 co-axial extension cable	279
Appendix F: Conduit Entry for Class I, Div 2 Applications	280
Programming chart	283
LCD Menu Structure	292
Index	299

Introduction

The HydroRanger 200 HMI (Human Machine Interface) ultrasonic level controller is intended for use in industrial areas. Operation of this equipment in a residential area may cause interference to several frequency based communications.

Please follow the installation and operating procedures for a quick, trouble-free installation and to ensure the maximum accuracy and reliability of your HydroRanger 200 HMI.

The Manual

This manual applies to the HydroRanger 200 HMI series only. It provides information to help set up your device for optimum performance, including:

- How to program the device
- Example applications
- Principles of operation
- Parameter values
- Parameter uses
- Outline diagrams
- Wiring diagrams
- Installation requirements
- Modbus[®] 1 register mapping
- Modem configuration







1. Modbus is a registered trademark of Schneider Electric.

We always welcome suggestions and comments about manual content, design, and accessibility. Please direct your comments to techpubs.smpi@siemens.com.

For other Siemens level measurement manuals, go to: www.siemens.com/level, and look under **Level Measurement**.

Manual symbols

Please note their use carefully.

	Alternating Current
	Direct Current
	Earth (ground) Terminal
	Protective Conductor Terminal
	Caution (refer to instructions)
	Service port

Application examples

The application examples used in this manual illustrate the versatility of the HydroRanger 200 HMI. There is often a number of different ways to approach an application, therefore varying configurations may apply.

In all examples, substitute your own application details. If the examples are not suitable to your application, check the relevant parameter references for other available options.

Firmware revision history

This history establishes the correlation between the current documentation and the valid firmware of the device.

Sensor node

Firmware Rev.	PDM EDD Rev.	Date	Changes
2.00.00	1.13.02	October 1, 2015	Initial release.

HMI

Firmware Rev.	Date	Changes
2.00.00	October 1, 2015	Initial release.

Safety notes

Special attention must be paid to warnings and notes highlighted from the rest of the text by grey boxes.



WARNING: Relates to a caution symbol on the product, and means that failure to observe the necessary precautions can result in death, serious injury, and/or considerable material damage.



WARNING¹: Means that failure to observe the necessary precautions can result in death, serious injury, and/or considerable material damage.

Note: means important information about the product or that part of the operating manual.

Safety marking symbols

In manual	On product	Description
		Earth (ground) Terminal (shield)
		Protective Conductor Terminal
		Dispose of in an environmentally safe manner, and according to local regulations.
		WARNING: refer to accompanying documents (manual) for details.
		CAUTION: Observe electrostatic discharge precautions prior to handling electronic components within the wiring compartment.

¹ This symbol is used when there is no corresponding caution symbol on the product.

FCC Conformity

US Installations only: Federal Communications Commission (FCC) rules

! WARNING: Changes or modifications not expressly approved by Siemens could void the user's authority to operate the equipment.

Notes:

- This equipment has been tested and found to comply with the limits for a Class A digital device, pursuant to Part 15 of the FCC Rules. These limits are designed to provide reasonable protection against harmful interference when the equipment is operated in a commercial environment.
- This equipment generates, uses, and can radiate radio frequency energy and, if not installed and used in accordance with the instruction manual, may cause harmful interference to radio communications. Operation of this equipment in a residential area is likely to cause harmful interference to radio communications, in which case the user will be required to correct the interference at his own expense.
- FCC Compliance for DC version applies to battery powered operation.

CE Electromagnetic Compatibility (EMC) Conformity

This equipment has been tested and found to comply with the following EMC Standards:

EMC Standard	Title
CISPR 11: 2009/EN 55011: 2009, Class A	Limits and methods of measurements of radio disturbance characteristics of industrial, scientific, and medical (ISM) radio-frequency equipment.
EN 61326-1:2013 IEC 61326-1:2012	Electrical Equipment for Measurement, Control and Laboratory Use – Electromagnetic Compatibility.
EN61000-3-2: 2006	Electromagnetic Compatibility (EMC) Part 3-2: Limits for harmonic current emissions (equipment input current \leq 16A per phase).
EN61000-3-3: 2008 A1: 2001 + A2: 2005	Electromagnetic Compatibility (EMC) Part 3-3: Limitation of voltage changes, voltage fluctuations, and flicker in public low voltage supply systems, for equipment with rated current \leq 16A per phase and not subject to conditional connection.
EN61000-4-2:2009	Electromagnetic Compatibility (EMC) Part 4-2: Testing and measurement techniques – Electrostatic discharge immunity test.
EN61000-4-3:2006	Electromagnetic Compatibility (EMC) Part 4-3: Testing and measurement techniques – Radiated, radio-frequency, electromagnetic field immunity test.
EN61000-4-4:2004	Electromagnetic Compatibility (EMC) Part 4-4: Testing and measurement techniques – Electrical fast transient/burst immunity test.

EMC Standard	Title
EN61000-4-5:2006	Electromagnetic Compatibility (EMC) Part 4-5: Testing and measurement techniques – Surge immunity test.
EN61000-4-6:2009	Electromagnetic Compatibility (EMC) Part 4-6: Testing and measurement techniques – Immunity to conducted disturbances, induced by radio-frequency fields.
EN61000-4-8:2010	Electromagnetic Compatibility (EMC) Part 4-8: Testing and measurement techniques – Power frequency magnetic field immunity test.
EN61000-4-11: 2004	Electromagnetic Compatibility (EMC) Part 4-11: Testing and measurement techniques - voltage clips, short interruptions and voltage variations immunity tests.

Description

Overview

The HydroRanger 200 HMI (Human Machine Interface) is a six-relay ultrasonic controller for Level and Volume measurements, available in single- or dual-point models. It has Open Channel Monitoring capabilities, a large number of advanced pump control algorithms, and is equipped with digital communications.

The HydroRanger 200 HMI features menu-driven programming and a host of wizards for plug and play performance, accessed through its four-button navigation panel with backlit graphical display.

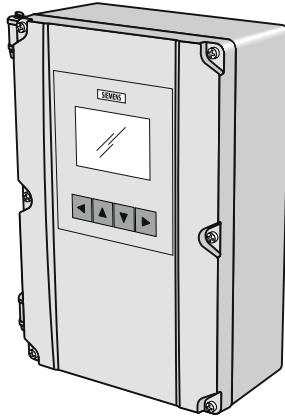

Features

- Easy to use interface with local push-button programming.
- Menu-driven parameters and wizard support for key applications.
- Level, Volume, and Open Channel Flow measurements.
- Six relays combined with a suite of pump, alarm, and relay control features.
- SIMATIC PDM connects directly to the device using Modbus.
- Two discrete inputs for backup level override.
- Communication using built-in Modbus RTU via RS-485.
- Compatible with SmartLinx[®] communications systems for PROFIBUS DPV0, PROFIBUS DPV1, and DeviceNet.
- Auto False Echo Suppression for fixed obstruction avoidance.

Applications

- Liquids, solids and slurry monitoring in small to large process and storage vessels or outdoor applications (open air).
- Fuel oil, municipal waste, acids, woodchips or on materials with high angles of repose.
- Key sample applications include: wet wells, flumes/weirs, bar screen control, hoppers, chemical storage, liquid storage, crusher bins, and dry solids storage.

Approvals and certificates

The HydroRanger 200 HMI is available with General Purpose and Hazardous Area approvals. For details, see the chart below.

Note: The device nameplate lists the approvals that apply to your device.

Application type	HydroRanger 200 HMI approval version	Approval rating	Valid for
Non-hazardous	General Purpose	CSA _{US/C} , CE, FM, UL, RCM	N. America, Europe, Australia
Hazardous	Non-incendive	CSA Class I, Div. 2, Groups A, B, C, D; Class II, Div 2, Groups F, G; Class III	Canada

Installing and mounting

Installing

Notes:

- Installation must only be performed by qualified personnel, and in accordance with local governing regulations.
- This product is susceptible to electrostatic shock. Follow proper grounding procedures.



All field wiring must have insulation suitable for at least 250V.



Hazardous voltages present on transducer terminals during operation.



DC input terminals shall be supplied from a source providing electrical isolation between the input and output, in order to meet applicable safety requirements of IEC 61010-1 (e.g. Class 2 or Limited Energy Source).



CAUTION: Observe electrostatic discharge precautions prior to handling electronic components within the wiring compartment.

- Relay contact terminals are for use with equipment that has no accessible live parts and wiring that has insulation suitable for at least 250 V. The maximum allowable working voltage between adjacent relay contacts shall be 250 V.
- The non-metallic enclosure does not provide grounding between conduit connections. Use grounding type bushings and jumpers.
- Before opening the lid, ensure that the inside of the enclosure will not be contaminated with liquids or dust from the local environment.
- Ensure power is removed from the HydroRanger 200 HMI before servicing. Follow all local electrical safety codes and guidelines.
- Ensure power is removed from the HydroRanger 200 HMI before disconnecting or connecting the HMI.
- The HydroRanger 200 HMI electronics must only be installed in the vented enclosure which accompanies the product.
- The equipment must be protected by a 15 A fuse or circuit breaker on all current-carrying conductors in the building installation.

Mounting locations

Recommended

- Ambient temperature is always within -20 to 50 °C (-5 to 122 °F).
- The HydroRanger 200 HMI display window is at shoulder level, unless most interactions are through a SCADA system.
- Clear access to the device, in order to have easy reach of the local push buttons or to swing the unit lid open unobstructed.
- Cable length requirements are minimal.
- Mounting surface is free from vibration.

Avoid

- Exposure to direct sunlight. (Provide a sun shield to avoid direct sunlight.)
- Close proximity to high voltage/current runs, contacts, SCR or variable frequency motor speed controllers.

Note: Recommended maximum torque for lid screws not to exceed 0.9 Nm (8 in-lbs.).

Mounting instructions

Note: When routing cable through a conduit, please follow the instructions on page 12 before mounting the HydroRanger 200 HMI.

Wall mount

Enclosure dimensions

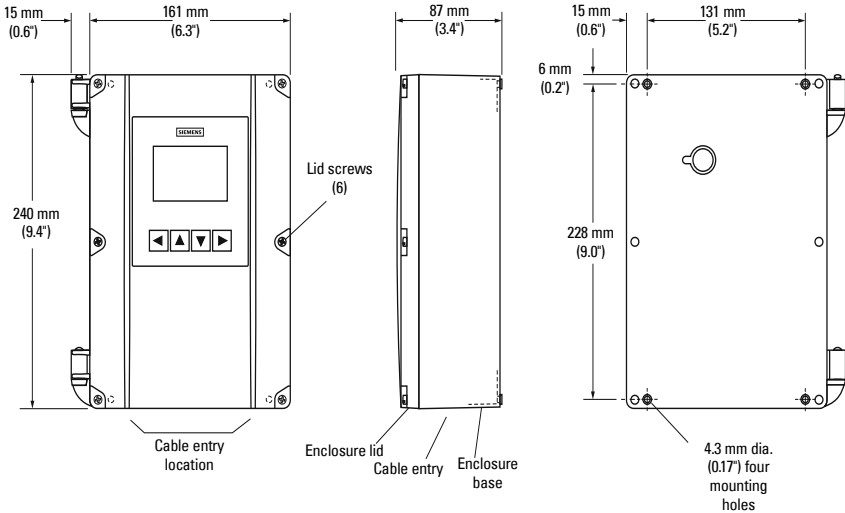

Mounting the enclosure

1. Remove the lid screws and open the lid to reveal the mounting screw holes.
2. Mark and drill four holes in the mounting surface for the four screws (customer supplied).
3. Fasten with a long screwdriver.

Please note:

- Recommended mounting: directly to wall or to electrical cabinet back panel.
- Recommended mounting screws: #6.
- If alternate mounting surface is used, it **MUST** be able to support four times the weight of the unit.

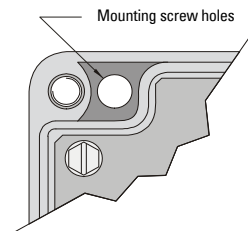

Cable routed through a conduit



CAUTION: Observe electrostatic discharge precautions prior to handling electronic components within the wiring compartment.

1. Disconnect the Display cable by pressing the locking tab and pulling it straight out.
2. Remove the four mounting screws holding the plastic cover and motherboard to the enclosure.
3. Remove the plastic cover by pulling it straight out. Be careful not to damage the motherboard and other electronic components with static electricity.
4. Remove the motherboard from the enclosure by pulling the board straight out. Be careful not to damage the electronics with static electricity.
5. Drill the required cable entry holes. Make sure conduit holes do not interfere with the lower areas on the terminal block, circuit board, or SmartLinx® card. Please see the illustration below.

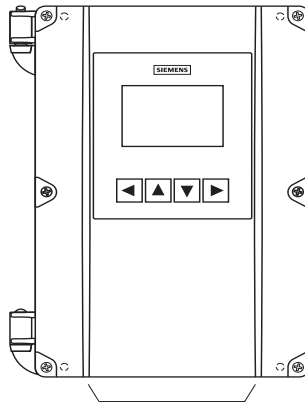

Suitable location for conduit entries. See recommended pattern below.

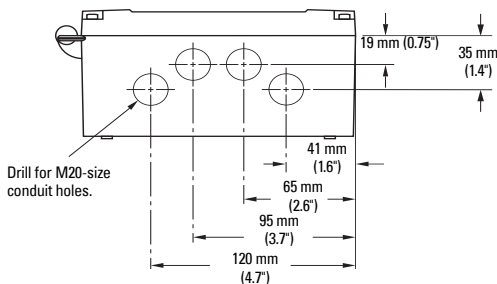

6. Attach the conduit to the hub before connecting the hub to the enclosure, using only approved suitable-sized hubs for watertight applications.
7. Reinstall the motherboard and plastic cover; secure them with the mounting screws.
8. Reconnect the Display cable.

Note: For conduit locations and assembly for hazardous mounting in Class I, Div 2 applications, please see Drawing A5E35806240A in *Appendix F: Conduit Entry for Class I, Div 2 Applications* on page 273.

Cable exposed and entering through the cable glands

1. Unscrew the glands and attach them loosely to the enclosure.
2. Thread the cables through the glands. To avoid interference, ensure that the power cable is kept separated from the signal cables, and then wire the cables to the terminal blocks.
3. Tighten the glands to form a good seal.

Note: Where more holes are required than are supplied in the enclosure, follow the instructions on *Cable routed through a conduit* on page 12.

Panel mount

Installing the panel mount unit requires making a cutout in the panel. The dimensions for the cutout are provided in the illustration below. A full size cutout template is provided with your unit or may be downloaded from www.siemens.com/processinstrumentation.

Cutout dimensions

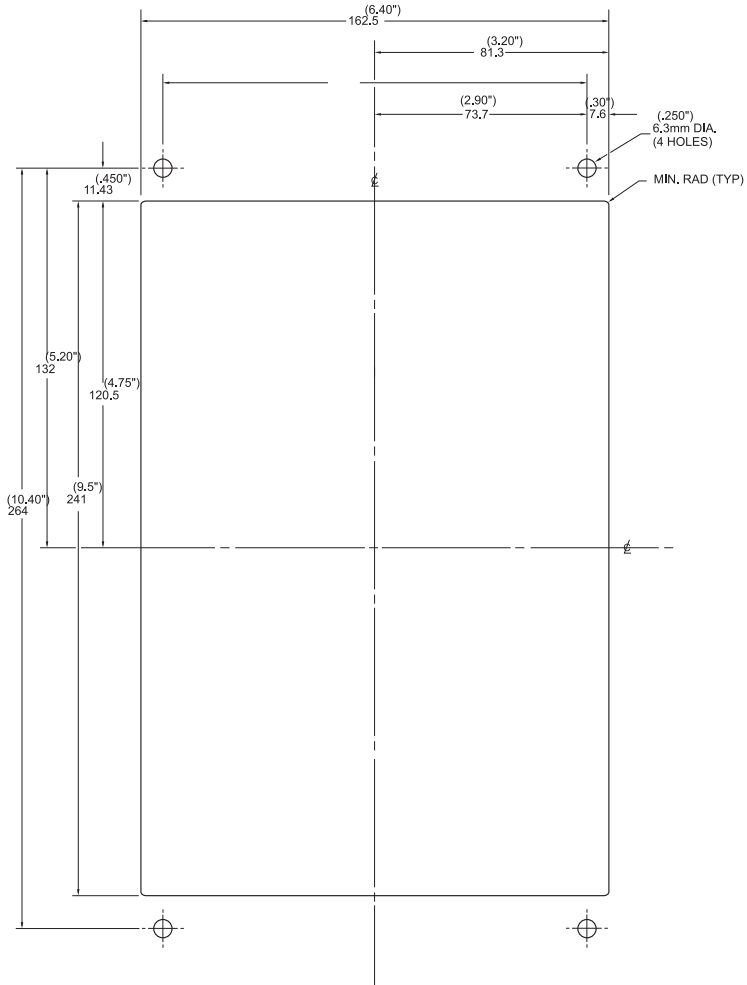

Cutout instructions

1. Select a place for the unit and fasten the template onto the panel (use tape or tacks).
2. Drill the four fastener holes.
3. Make the cutout using the appropriate tools.
4. Mount unit according to the instructions on page 15.

Panel mount dimensions

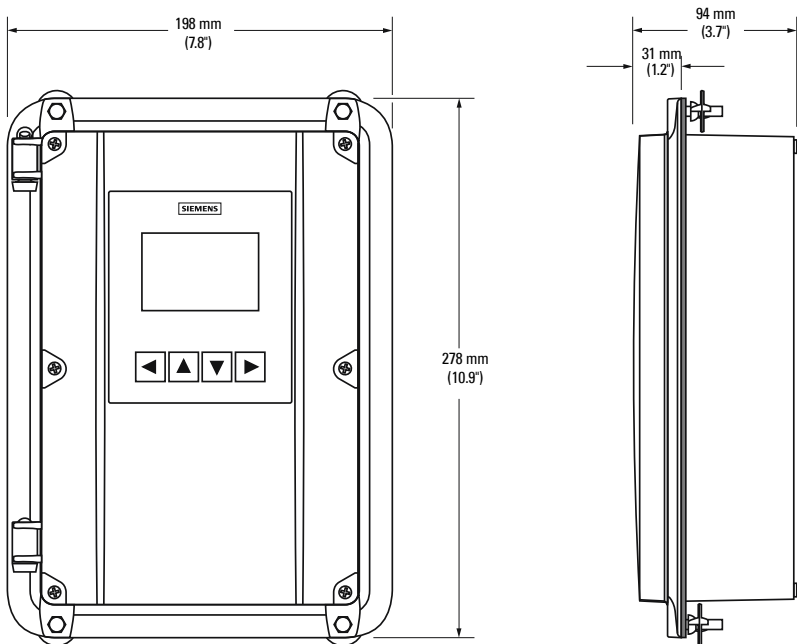

Mounting the enclosure

Once cutout is complete and mounting holes are drilled, follow these steps:

1. Remove the lid from the device by undoing its six lid screws and lifting it off its hinges.
2. Disconnect the display cable by pressing the locking tab and pulling straight out.
3. Remove the four screws holding the plastic cover and motherboard to the enclosure.
4. Remove the plastic cover by pulling it straight out. Be careful not to damage the motherboard electronics with static electricity.
5. Remove the motherboard from the enclosure by pulling the board straight out. Be careful not to damage the electronics with static electricity.
6. Drill the required cable entry holes. Be sure to compensate for panel door dimensions and make sure conduit holes do not interfere with the lower areas on the terminal block, circuit board, or SmartLinx[®] card.
7. Reinstall the motherboard and plastic cover; secure them with the mounting screws.
8. Reconnect the display cable.
9. Place the unit into the panel and insert hexagonal fasteners through bevel slots and pre-drilled panel holes.
10. Fasten with wingnuts and hand tighten.
11. Add conduit or glands and wire as required.

Helpful hint: Use tape to hold the hexagonal heads in slots while attaching the wingnuts.

HydroRanger 200 HMI wiring compartment



WARNING: Check the device label on your instrument to verify the approval rating.

Use appropriate conduit seals to maintain applicable IP and NEMA ratings.



CAUTION: Ensure the terminal strips are terminated to the correct location during re-installation. Failure to do so may result in damage to the device or the external equipment that is attached.

Notes:

- Terminal strips can be removed to improve ease of wiring.
- Separate cables and conduits may be required to conform to standard instrumentation wiring practices or electrical codes.

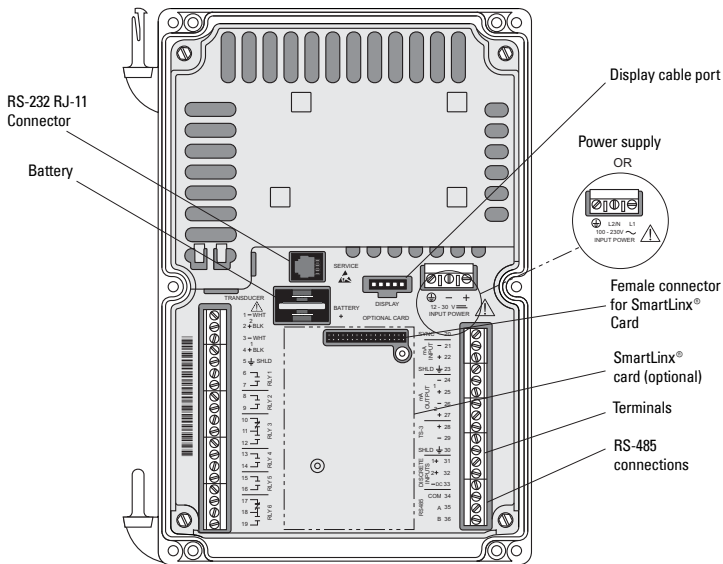

Replacing the battery

The HydroRanger 200 HMI comes pre-installed with a battery to power the RAM that stores parameter settings and totalizer values in between hourly backups to non-volatile memory. It is important to always have a working battery installed in the device to ensure that settings and values are not lost.



WARNING: Disconnect power before replacing the battery.

Notes on the battery:

- Number: BR2032
- Life expectancy: 10 years
- Type: Lithium metal coin cell



Dispose of battery in an environmentally safe manner, and according to local regulations.

Installing a replacement battery

1. To ensure that the most recent data is written to non-volatile memory, use the local push buttons to enter Program mode by pressing **▶**.
2. Return to Measurement mode by pressing **◀**.
3. Disconnect power to the device.
4. Open the enclosure lid.
5. Slide the old battery out of the holder.
6. Slide the new battery into the battery holder. Make sure it is positioned in the correct polarity in accordance to the label.
7. Close and secure the enclosure lid.

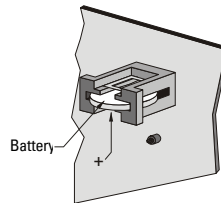

Installing the SmartLinX[®] communications card

SmartLinX[®] communications cards are generally pre-installed. If unit does not have a SmartLinX[®] card, follow these steps to install one:

1. Disconnect power to the device.
2. Align card with the two mounting posts and then press-fit with the female connector.
3. Use the screws supplied with the card to attach it to the mounting posts.
4. Wire in the SmartLinX[®] card according to SmartLinX[®] manual.

⚠ WARNING: Disconnect power before installing the communication card.

Note: For EMC compliance, it is necessary to install the provided clamp-on ferrite to the communications cable, at the connection point to the SmartLinX[®] card.

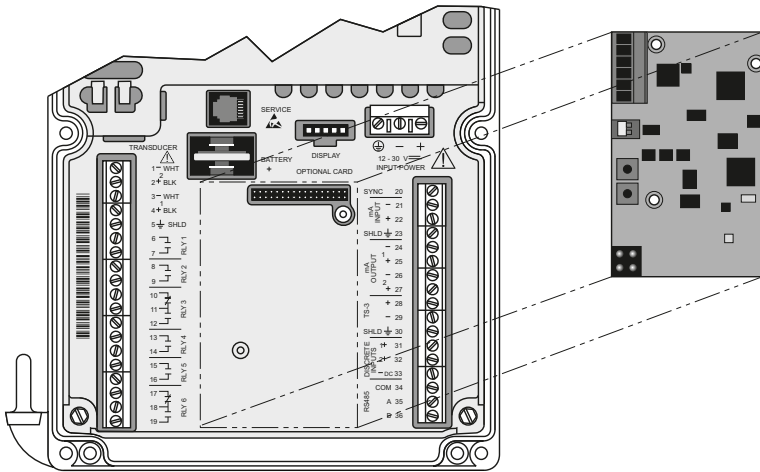

Safety notes for connection

- Verify that all system components are installed in accordance with instructions.
- Connect all cable shields to the HydroRanger 200 HMI shield terminals to avoid differential ground potentials.
- Keep exposed conductors on shielded cables as short as possible to reduce noise on the line caused by stray transmissions and noise pickup.

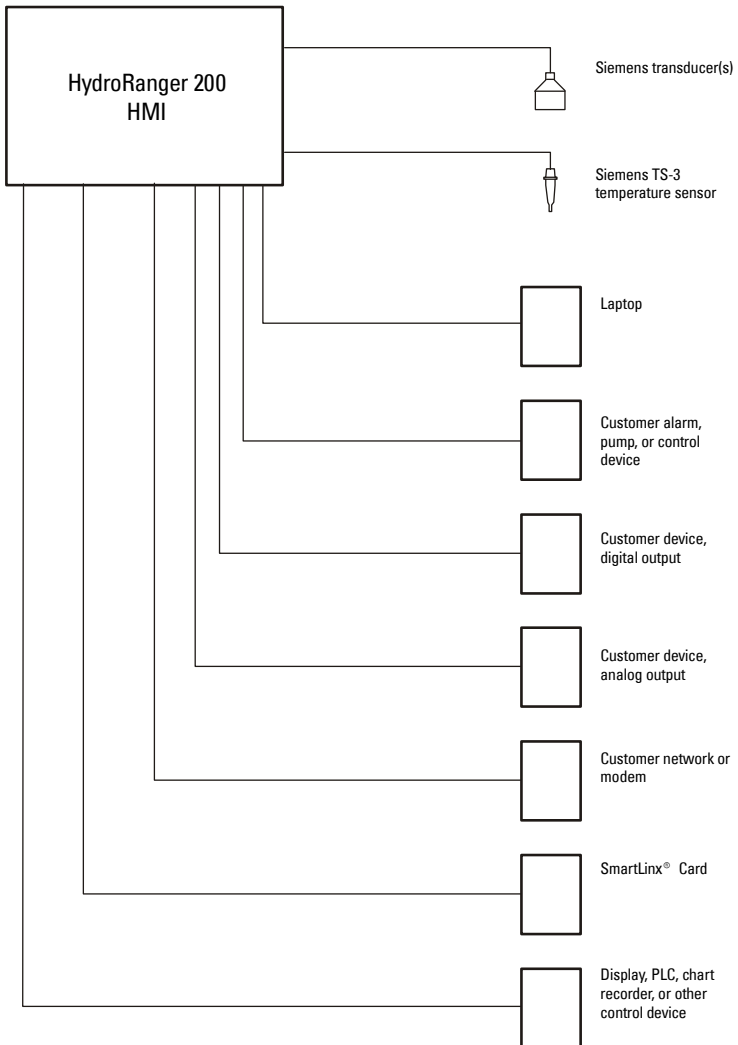

Terminal board

Note: Recommended torque on terminal clamping screws.

- 0.56 - 0.79 Nm
- 5 - 7 in.lbs

Please do not overtighten the screws.

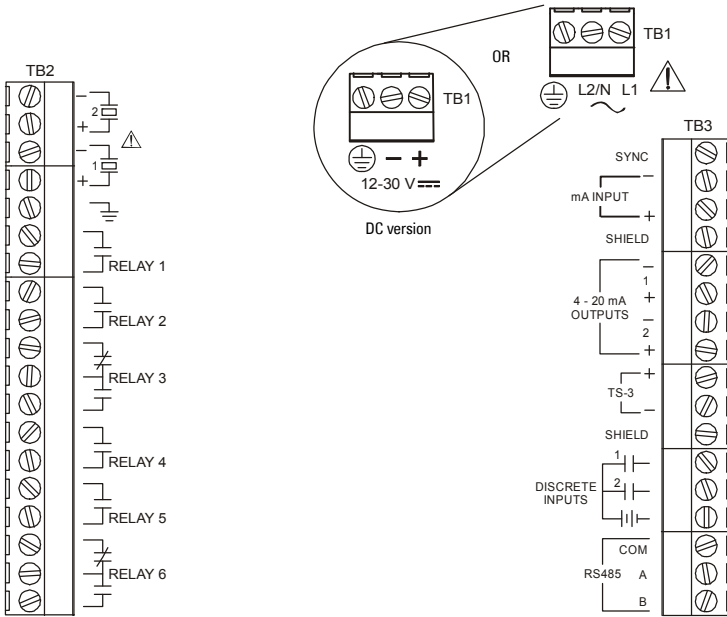

Cables

The HydroRanger 200 HMI transceiver requires a shielded two-wire connection to the transducer.

Connection	Cable type
mA input and mA output sync, temperature sensor, discrete input, DC input, transducer	2 copper conductors, twisted, with shield ¹ /drain wire, 300V 0.324 - 0.823 mm ² (22 - 18 AWG) Maximum length: 365 m
Relay output, AC input	Relay to be copper conductors per local requirements to meet 250 V 5A contact rating.
	Using a co-axial transducer cable extension with the HydroRanger 200 HMI is NOT recommended. If it is really necessary to use this cable, see <i>Appendix E: Upgrading, Co-axial transducer extension</i> on page 271.

1. Preferred shielding is braided screen.

Transducers



Warning: Hazardous voltage present on transducer terminals during operation.

Notes:

- Using a co-axial transducer cable extension with the HydroRanger 200 HMI is NOT recommended. If it is really necessary to use such cable, see *Appendix E: Upgrading, Co-axial transducer extension* on page 271 for instructions..
- Do not connect the shield and white transducer wires together; wire to separate terminals.
- Disregard older transducer manuals that recommend practices different from those listed above.

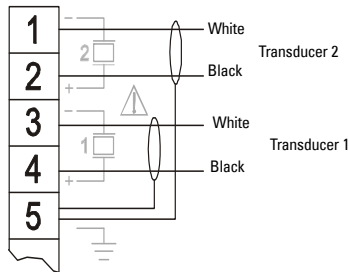

A 0.1 μF (100V or greater) capacitor is included with the HydroRanger 200 HMI for retrofitting old MultiRanger Plus installations. For instruction on how to use a co-axial cable, see *Appendix E: Upgrading, Co-axial transducer extension* on page 271.

Relays

Relay contacts are shown in the de-energized state. All relays are handled identically and can be configured as positive or negative logic using parameter Relay Logic (2.8.1.11.) on page 144.

Relay ratings

- Four Form **A**, NO relays(1,2,4,5)
- Two Form **C**, NO or NC relays (3,6)
- 5A at 250Vac, non-inductive

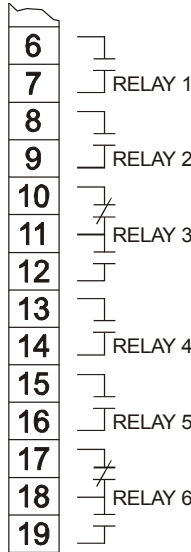

Power Failure

All relays will fail in their de-energized states. Relays 1, 2, 4, and 5 are normally open and will fail open.

Relays 3 and 6 can be wired either normally open or normally closed.

Temperature sensor

Accurate temperature readings are critical to accurate level measurements because the speed of sound changes, depending on air temperature, and all Siemens Echomax and ST-H transducers have an internal temperature sensor.

Having a separate TS-3 temperature sensor will ensure optimum accuracy if the following conditions apply:

- The transducer is exposed to direct sunlight (or other radiant heat source).
- The transducer face and monitored surface temperature differs.
- Faster response to temperature changes is required.

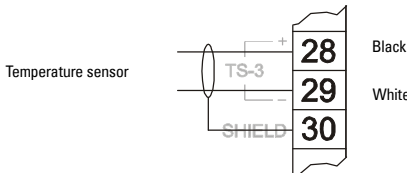

To achieve the best performance of temperature measurement in a typical open channel flow application, the temperature sensor should be shielded from direct sunlight and mounted halfway between the ultrasonic transducer face and the maximum head

achievable in the application. Care should be taken to avoid obstructing the direct sound path of the ultrasonic transducer.

Note: Use a TS-3 Temperature Sensor only. Leave terminals open (unused) if TS-3 is not deployed.

mA Input

For more information, consult parameters Transducer (2.1.5.) on page 118, mA Input Range (2.6.1.) on page 133, 0/4 mA Level Value (2.6.2.) on page 133, and 20 mA Level Value (2.6.3.) on page 133.

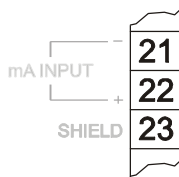

mA Output

For more information, consult parameter Current Output (2.5.) on page 129.

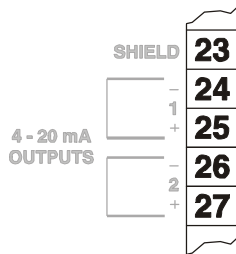

Level system synchronization

Note: The HydroRanger 200 HMI CANNOT be synchronized with the MultiRanger Plus or the HydroRanger.

When using multiple ultrasonic level monitors, running the transducer cables in separate grounded metal conduits is recommended.

When separate conduits are not possible, synchronize the level monitors so that no unit transmits while another is waiting for echo reception.

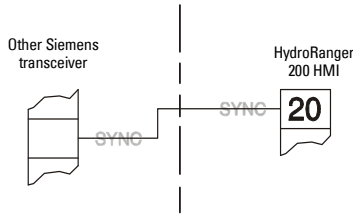

Synchronizing with another HydroRanger 200 HMI, or other Siemens instruments (DPL+, SPL, XPL+, LU01, LU02, LU10, LUC500, Hydro+, EnviroRanger, MiniRanger, SITRANS LUT400):

- Mount the level monitors together in one cabinet.
- Use a common power (mains) supply and ground (earth) for all units.
- Interconnect the SYNC terminals of all level monitors
- Set parameter Shot Synchro (2.1.13.) on page 120.
- For assistance, contact your Siemens representative, or go to www.siemens.com/processinstrumentation.

Power

Warning: Before applying power to the HydroRanger 200 HMI for the first time, ensure any connected alarm/control equipment is disabled until satisfactory system operation and performance is verified.

Notes for AC power connections:

- The equipment must be protected by a 15 A fuse or circuit breaker on all current-carrying conductors in the building installation.
- A circuit breaker or switch in the building installation, marked as the disconnect switch, must be in close proximity to the equipment and within easy reach of the operator, and must disconnect all current-carrying conductors.

Note: Make sure that the device is connected to a reliable ground.

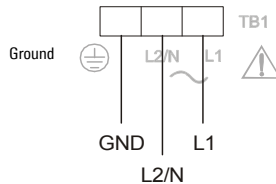

Digital communications

Wiring the HydroRanger 200 HMI for communications allows it to be integrated into a full SCADA system or an industrial LAN.

The HydroRanger 200 HMI can also be directly connected to a computer running SIMATIC PDM.

RS-232 serial connection

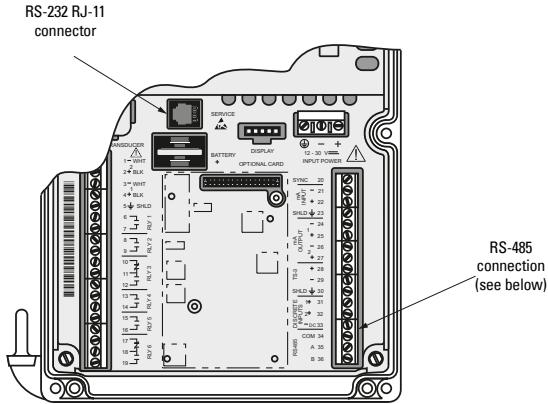

RS-485 serial connection

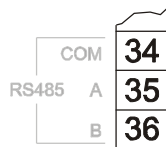

Discrete inputs

Discrete inputs that have a positive and negative terminal require an external power supply.

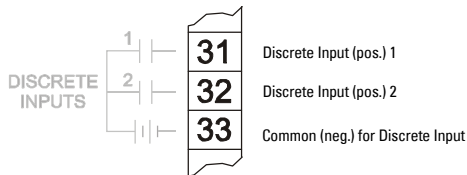

Commissioning

Local commissioning

The HydroRanger 200 HMI is built for easy operation, making it possible to be commissioned quickly. Its parameters are menu-driven and can be modified locally using the LCD and push buttons, also known as the Human Machine Interface (HMI).

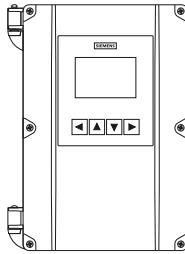

Local push buttons

A Quick Start Wizard provides simple step-by-step procedures to help you configure the device for various applications. We recommend that configuration is done in the following order:

1. Run the appropriate Quick Start Wizard for your application (Level, Volume, Flow).
2. Set up pumps via the Pump Control Wizard (if applicable).
3. Configure alarms, or other controls, totalizers and samplers, referencing the respective parameters (see page 111). It is important that alarms, and other controls are configured last to avoid pump relay assignments being overridden by the Quick Start Wizard.

See *Level application* on page 58 or *Flow application* on page 59 for illustration examples. For the complete range of parameters, see page 111.

Activating the HydroRanger 200 HMI

Notes:

- The HydroRanger 200 HMI has two modes of operation: **RUN** and **PROGRAM**.
- While the device is in PROGRAM mode, outputs are de-activated and the device does not measure the process.
- To enter PROGRAM mode using the device local push buttons, press ►. Press ◀ to return to Measurement mode.
- The display will return to Measurement mode after ten minutes of inactivity (from last button press), when in PROGRAM Mode and from within a Wizard. Pressing ► will then take you to the main navigation menu. (It will not return to the screen from which the timeout occurred.)

RUN Mode

In RUN mode, the HydroRanger 200 HMI detects material level and provides control functions. The HydroRanger 200 HMI automatically starts in RUN mode when power is applied.

System status is shown on the unit's LCD, or on a remote communications terminal.

Measurement Views in RUN mode

The HydroRanger 200 HMI provides two measurement views. Measurement View 1 displays the Primary Reading, while Measurement View 2 displays both the Primary Reading and the Auxiliary Reading. When the HydroRanger 200 HMI is in RUN mode, you can switch between these views using the ▲ and ▼ arrow keys.

The value displayed in Primary Reading is determined by parameter 2.1.3. *Sensor Mode*. On the other hand, the value displayed in Auxiliary Reading is preset when you adjust 2.1.3. *Sensor Mode*, although you can change the selection later using 2.12.7. *Default Auxiliary Reading*.

The LCD Display

Measurement Mode Display: Normal operation

Startup Splash screen

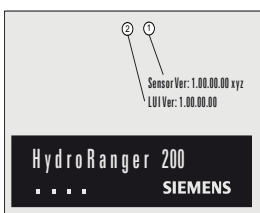

Measurement View 1

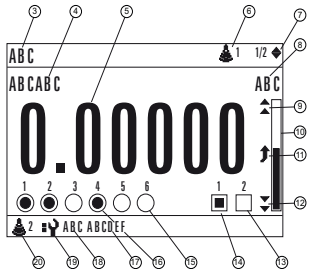

Measurement View 2

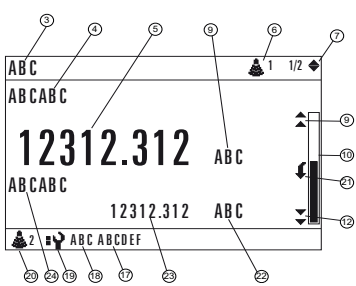

- 1 – Firmware version of sensor board
- 2 – Firmware version of display board
- 3 – Tag
- 4 – Primary reading type
- 5 – Primary reading
- 6 – Point identifier
- 7 – Current view number
- 8 – Primary reading units
- 9 – Level alarm status (high)
- 10 – Level bargraph
- 11 – Filling
- 12 – Level alarm status (low)
- 13 – Discrete inputs (inactive)
- 14 – Discrete inputs (active)
- 15 – Relay (inactive)
- 16 – Relay (active)
- 17 – Fault text
- 18 – Fault number
- 19 – Device status indicator
- 20 – Fault point
- 21 – Emptying
- 22 – Auxiliary reading units
- 23 – Auxiliary reading
- 24 – Auxiliary reading name

1. Press UP or DOWN arrow to switch

Display field descriptions

Display field	Description
Tag	A short description that can be set using parameter <i>3.1.1. Tag</i>
Primary Reading type	Identifies the type of measurement shown in the Primary Reading field.
Primary Reading	Displays the value of the Primary Reading. This value is selected by using a Quick Start Wizard or parameter <i>2.1.3. Sensor Mode</i> . See Operation for more information on how to select a value.
Point Identifier	Level Point number for data currently displayed. See Measurement View scrolling for more information.
Current View Number	Displays the number of the Measurement View (1 or 2).
Primary Reading Units	The measurement of units corresponding to the Primary Reading. The field will be blank if the Primary Reading has no units.
Level Alarm Status (high/low)	Show the Hi/Hi-Hi and Lo/Lo-Lo level alarm statuses. Will display if one or more relays have been programmed for level alarms. See parameter <i>2.8.1.4. Relay Function</i> for information about programming level alarms.
Level Bar Graph	Bar graph indicator that visually represents the level of the Point being displayed
Filling/Emptying	Indicates if the level is rising or falling. See parameters <i>2.3.9. Filling Indicator</i> and <i>2.3.10. Emptying Indicator</i> for information about programming.
Discrete Inputs (active/inactive)	Displays information about which discrete inputs are programmed and the current state of each input. Discrete inputs are used to trigger or alter the way the HydroRanger 200 HMI controls devices such as pumps and alarms.
Relays	Information about which relays are programmed and what the current states of each relay are.
Fault Text	If there is a fault, this displays the description of the active fault. If there is no fault, the field will appear blank.
Fault Number	If there is an active fault, this field displays the number of the fault. See <i>General fault codes</i> on page 213 for descriptions of possible faults.
Device Status Indicator	If two faults are present at the same time, the device status indicator and text for the highest priority will display.
Fault Point	The point number (1 or 2) of the fault.
Auxiliary Reading Units	The measurement units corresponding to the Auxiliary Reading. The field will appear blank if the Auxiliary Reading has no units.
Auxiliary Reading	Displays the value of the Auxiliary Reading. The value shown here is selected using parameter <i>2.12.7. Default Auxiliary Reading</i> . See Auxiliary Reading below for more information on how to select the value display.
Auxiliary Reading Name	Identifies the value shown in the Auxiliary Reading field.

Auxiliary Reading

Measurement View 2 displays an Auxiliary Reading area in addition to the Primary Reading. The Auxiliary Reading can display additional information that you choose.

Setting a specific Auxiliary Reading

To set the value initially displayed in the Auxiliary Reading, use parameter *2.12.7. Default Auxiliary Reading*.

The Auxiliary Reading value that you choose is automatically synchronized with the Primary Reading value as the display scrolls through the Level Points. For example, if the

Primary Reading is **Level** and you have chosen **Volume** for the Auxiliary Reading, the HydroRanger 200 HMI will always show **Level** (in the Primary) and **Volume** (in the Auxiliary) for the same Level Point. The Level Point is shown in Measurement Mode Display as caption number 6 on page 28.

Temporarily overriding the Auxiliary Reading

You can temporarily override the value displayed in the Auxiliary Reading by pressing the ◀ button in RUN mode. This allows you to see values in the Auxiliary Reading area that are not associated with a particular Level Point.

For example, you may have configured the Primary Reading to display Flow, and the Auxiliary Reading to display Head. If you want to see what the milliamp outputs are, you can press the ◀ button. This first press of ◀ will temporarily replace the Auxiliary Reading with milliamp output #1. Press the ◀ button again to display milliamp output #2, and press it a third time to see the milliamp input.

The HydroRanger 200 HMI will continue to display your selected temporary value until the next power cycle. After a power cycle, the HydroRanger 200 HMI will show the default auxiliary reading (see 2.12.7. *Default Auxiliary Reading on page 173*) when you display Measurement View 2.

Multiple readings

During **differential** or **average** operation (2.1.3. *Sensor Mode= Dual-Point Difference/ Dual-Point Average*), Measurement Views 1 and 2 scrolls sequentially through Point Numbers 1, 2, and 3. Point 3 is the difference between (or average of) Points 1 and 2.

Changing number scrolling speed



Parameter	Value	Description
2.12.8. <i>Display Delay</i>	5	Hold each value for 5 seconds

PROGRAM Mode

The HydroRanger 200 HMI is programmed by setting its parameters to match your specific application. Most parameters are indexed, allowing you to set the parameter to specific conditions and to more than one input or output. When the HydroRanger 200 HMI is in PROGRAM mode, you can change these parameter values and set operating conditions.



The HydroRanger 200 HMI's primary programming is through the four-button interface. Please refer to page 111 for a full listing and explanation of parameter values.

Key functions in Measurement mode

Key	Function	Result
	RIGHT arrow opens PROGRAM mode.	Opens the top level menu.
	LEFT arrow displays the next Auxiliary Reading value in Measurement View 2.	Scrolls through a list of available Auxiliary Reading values, such as Distance, Temperature, or Milliamp Output. See <i>2.12.7. Default Auxiliary Reading on page 173</i> for a complete list.
	UP or DOWN arrow toggles between Measurement View 1 and Measurement View 2.	LCD displays Measurement View 1 or 2.

Programming the HydroRanger 200 HMI

Notes:

- To enter PROGRAM mode using the device local push buttons, press . Press  repeatedly to return to RUN mode.
- While the device is in PROGRAM mode, outputs are de-activated and the device does not measure the process.

Change parameter settings and set operating conditions to suit your specific application.

Parameter menus

Note: For the complete list of parameters with instructions, see *Parameters* on page 111.

Parameters are identified by name, organized into function groups, then arranged in a 5-level menu structure, as in the example below. (For the full menu, see *LCD Menu Structure* on page 290.)



- 1. WIZARDS
- 2. SETUP
 - 2.1. SENSOR
 -
 - 2.8. RELAYS
 - 2.8.1. BASIC SETUP
 - 2.8.2. MODIFIERS
 - 2.8.2.6. WALL CLING REDUCTION
 - 2.8.2.6.1. TRANSDUCER SELECTOR

1. Enter PROGRAM mode



Using local push buttons:

RIGHT arrow ► activates PROGRAM mode and opens menu level 1.

2. Navigating: key functions in PROGRAM mode

Notes:

- In PROGRAM mode, **ARROW keys** move to the next menu item in the direction of the arrow.
- Press and hold any arrow key to scroll through a list of options or menus (in the direction of the arrow).
- A visible scroll bar indicates the menu list is too long to display all items.

Key	Name	Menu level	Function
	UP or DOWN arrow	Menu or parameter	Scroll to previous or next menu or parameter.
	RIGHT arrow	Menu	Go to first parameter in the selected menu, or open next menu.
		Parameter	Open Edit mode.
	LEFT arrow	Menu or parameter	Open parent menu.

3. Editing in PROGRAM mode







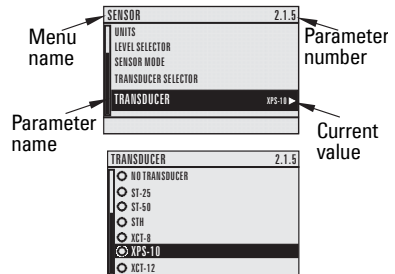

Selecting a listed option



- Navigate to the desired parameter.
- Press **RIGHT arrow** ► to open **Edit** mode. The current selection is highlighted.
- Scroll to a new selection.
- Press **RIGHT arrow** ► to accept it.

The LCD returns to parameter view and displays the new selection.





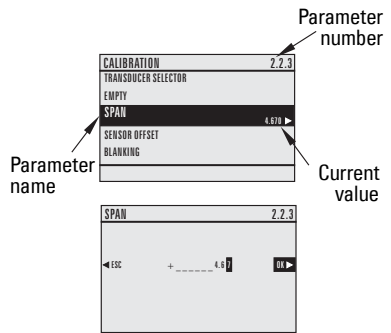

Changing a numeric value

- Navigate to the desired parameter.
- When selected, the current value is displayed.
- Press **RIGHT arrow**  to open **Edit** mode. The cursor position is highlighted.
- Use **LEFT**  and **RIGHT arrow**  to move cursor to digit position you wish to change.
- As each digit is highlighted (selected), use the **UP**  and **DOWN arrow**  to increase or decrease the digit respectively.
- While decimal point is selected, use **UP**  and **DOWN arrow**  to shift decimal position.
- To escape without saving your changes, press **LEFT arrow**  continually until **ESC** is highlighted. Press **LEFT arrow**  again to escape without saving changes.

Otherwise, when new parameter value is correct, press **RIGHT arrow**  continually until **OK** is highlighted.
- Press **RIGHT arrow**  to accept the new value. The LCD returns to parameter view and displays the new selection. Review for accuracy.



Key functions in Edit mode

Key	Name		Function
 	UP or DOWN arrow	Selecting options	Scrolls to item.
		Alpha-numeric editing	- Increments or decrements digits. - Toggles plus and minus sign.
	RIGHT arrow	Selecting options	- Accepts the data (writes the parameter). - Changes from Edit to Navigation mode.
		Numeric editing	- Moves cursor one space to the right - or with selection highlighted, accepts the data and changes from Edit to Navigation mode.
	LEFT arrow:	Selecting options	Cancels Edit mode without changing the parameter
		Numeric editing	- Moves cursor to plus/minus sign if this is the first key pressed - or moves cursor one space to the left. - or with cursor on Enter sign, cancels the entry

Quick Start Wizards

Wizards provide step-by-step Quick Start (QS) procedures that configure the device for simple applications. To configure the HydroRanger for applications of Level, Volume (standard vessel shapes), or Flow, see *Setting wizards via graphical display* below.

The SIMATIC PDM software is meant for applications employing more complex vessel shapes. See page 251 for more information.

Before initiating a Quick Start Wizard to configure the device, you may wish to gather the necessary parameter values. Parameter Configuration Charts that list all parameters and available options for each application type are available at: www.siemens.com/process_automation. You can record data and select from options on the chart that apply to your application, then with this data on hand, complete the *Setting wizards via graphical display* below, or via another Quick Start Wizard, as referenced above.

Setting wizards via graphical display

- 1) Press **RIGHT arrow** ► to enter PROGRAM mode.
- 2) Choose *1. Wizards > 1.1. Quick Start*, and then the appropriate quick start: *1.1.1. QS Level*, *1.1.2. QS Volume*, *1.1.3. QS Flow*, or *1.2. Pump Control*.
- 3) At each step, press **DOWN arrow** ▼ to accept default values and move directly to the next item, or **RIGHT arrow** ► to open Edit mode: the current selection is highlighted.
- 4) In Edit mode, scroll to desired item and press **RIGHT arrow** ► to store the change, then press **DOWN arrow** ▼ to continue.
- 5) Repeat steps 3 and 4 until you complete all the settings and get a prompt to configure another measurement point or relay (for Pump Control wizard). Pressing ► for YES lets you set another point or relay. Pressing ▼ for NO takes you to the end of the chosen wizard.
- 6) Press ▼ to FINISH and apply the settings made in that particular wizard. The display will then return to PROGRAM menu. Press ◀ to return to Measurement mode.

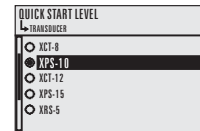
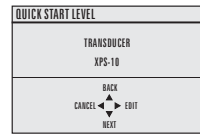

While configuring the device through the wizards, you can press **UP arrow** ▲ to go one step back, or **LEFT arrow** ◀ to cancel.

Notes:

- The Quick Start Wizard settings are inter-related and changes apply only after you choose Finish in the final step.
- Perform customization for your application only after the Quick Start has been completed.
- The following are key terms used throughout the QSW and Parameters:
 - Default** - the factory-set value or option; indicated with an **asterisk (*)** or specified as a **preset value**.
 - Global** - pertains to values that are common for all inputs and outputs on the unit.
 - Index** - when parameters apply to more than one input, they are indexed. The index selector value defines the input/output for that parameter. For example, index relates to transducer inputs or mA outputs, and can also refer to relays, communications ports, and other parameters.

1. Wizards

1.1. Quick Start

1.1.1. QS Level

Use this wizard to configure simple Level applications.

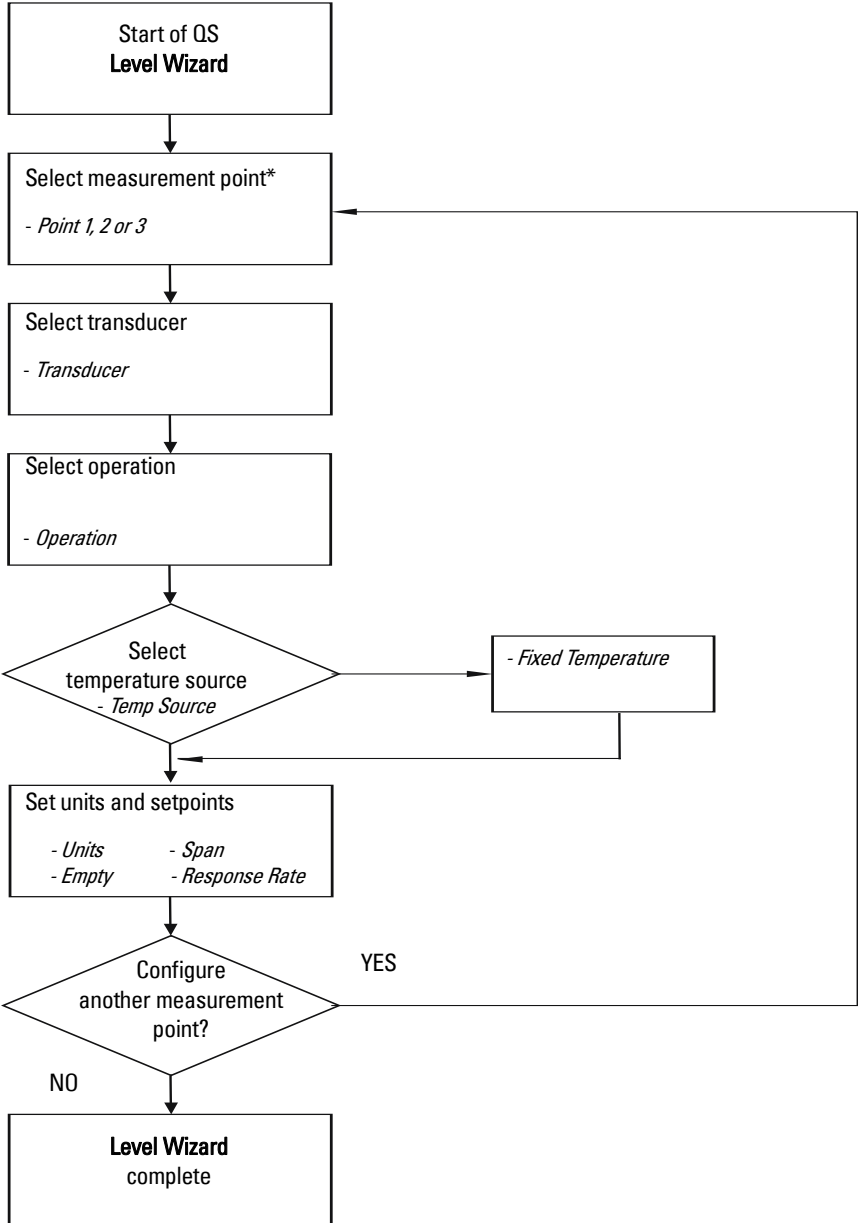

*Available only on dual-point models.

Start of QS Level Wizard

Shows the type of Wizard to be executed.

Options	CANCEL
	START

Measurement Point Selector

Selects the measurement points to configure.

Note: This is available on the dual-point model only.

Options	Point 1
	Point 2
	Point 3

Transducer

Specifies the model of the Siemens transducer connected to the device.

Index	Single-point model	Dual-point model
		Global
Options	*No transducer (dual-point preset)	
	ST-25	
	ST-50	
	STH	
	XCT-8	
	*XPS-10 (single-point preset)	
	XCT-12	
	XPS-15	
	XRS-5	
	mA input	

Operation

Sets the type of measurement (and the corresponding mA output) required for the application.

Mode	Description	Reference point
Out of Service	Level Point is not activated.	Not applicable
Level	Height of material	2.2.4. Empty
Space	Distance to material surface.	2.2.2. Span
Distance		Sensor reference point

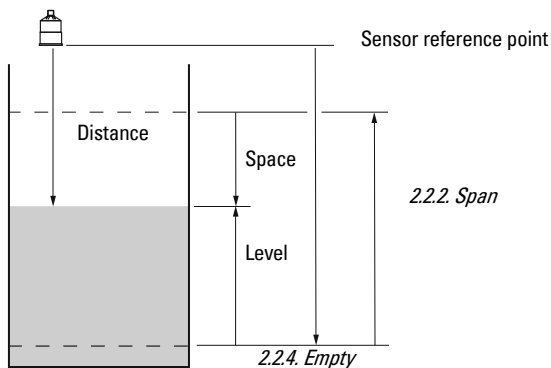

Temperature Source

Selects the source of the temperature reading used to adjust the speed of sound.

Index	Transducer
Options	*AUTO
	Fixed Temperature
	Transducer
	External TS-3
	Average of Sensors

See 2.11.1.4. *Temperature Source* on page 157 for more information.

Fixed Temperature

Sets the temperature of the source when there is no temperature-sensing device connected.

This parameter only displays if Fixed Temperature is selected for Temperature Source.

Value	Range: -100.0 to +150.0 °C
	Default: +20.0 °C

Units

Sensor measurement units.

Options	*M (meters)
	CM (centimeters)
	MM (millimeters)
	FT (feet)
	IN (inches)

Note: For the purpose of this example, all values are assumed to be in meters

Empty

Sets the distance from the face of the transducer to the process empty point.

Index	Level
Values	Range: 0.000 to 99.000 m
	Preset: 5.000 m

Span

Sets the range to be measured.

Index	Level
Options	Range: 0.000 to 99.000 m (or equivalent, depending on 2.1.1. Units)
	Preset: based on 2.2.4. Empty

Response Rate

Sets the reaction speed of the device to measurement changes in the target range.

Notes:

- Any changes made to 2.3.2. Fill Rate/minute, 2.3.3. Empty Rate/minute, or 2.3.4. Response Rate parameters following the completion of the wizard will supersede the Response Rate setting.
- Response Rate always displays in meters per minute (m/min).

Index	Transducer
Options	Slow (0.1 m/min)
	*Medium (1.0 m/min)
	Fast (10.0 m/min)

Use a setting just faster than the maximum filling or emptying rate (whichever is greater). Slower settings provide higher accuracy, faster settings allow for more rapid level fluctuations.

Configure another measurement point

Gives option to configure more measurement points or end the wizard.

Note: This is available on the dual-point model only.

Options	YES	Returns to the Measurement Point menu.
	NO	Completes the QS Level configuration.

End of QS Level Wizard

For QS to be successful, all changes must be applied.

Options	BACK, CANCEL, FINISH (Display returns to 1.1 Quick Start menu when Quick Start is successfully completed or cancelled. If CANCEL is selected, no changes are written to the device.)
----------------	-----------------------------------------------------------------------------------------------------------------------------------------------------------------------------------------

To transfer Quick Start values to the device and return to PROGRAM menu, press **DOWN arrow ▼ (Finish)**. Then press **LEFT arrow ◀** three times to return to Measurement mode.

1.1.2. QS Volume

Use this wizard to configure Volume applications employing standard vessel shapes.

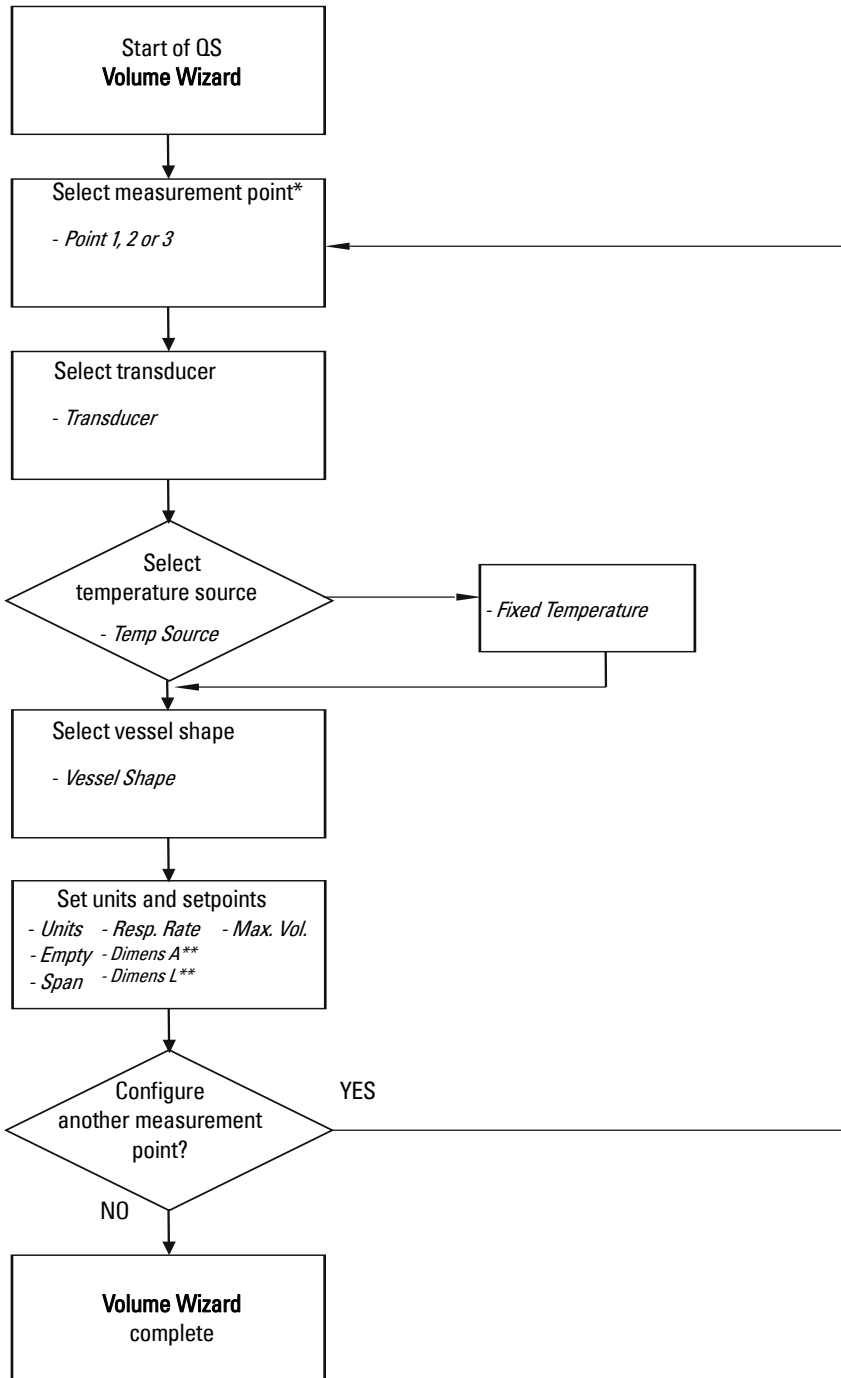

*Available only on dual-point models. **Depends on choice of Vessel Shape.

Start of QS Volume Wizard

Shows the type of Wizard to be executed.

Options	CANCEL
	START

Measurement Point Selector

Selects the measurement points to configure.

Note: This is available on the dual-point model only.

Options	Point 1
	Point 2
	Point 3

Transducer

Specifies the model of the Siemens transducer connected to the device.

Index	Single-point model	Dual-point model
		Global
Options	*No transducer (dual-point preset)	
	ST-25	
	ST-50	
	STH	
	XCT-8	
	*XPS-10 (single-point preset)	
	XCT-12	
	XPS-15	
	XRS-5	
	mA input	

Temperature Source

Selects the source of the temperature reading used to adjust the speed of sound.

Index	Transducer
Options	*AUTO
	Fixed Temperature
	Transducer
	External TS-3
	Average of Sensors

See 2.11.1.4. *Temperature Source* on page 157 for more information.

Fixed Temperature

Sets the temperature of the source when there is no temperature-sensing device connected.

This parameter only displays if Fixed Temperature is selected for Temperature Source.

Value	Range: -100.0 to +150.0 °C
	Default: +20.0 °C

Vessel Shape

Defines the vessel shape and allows the HydroRanger to calculate **Volume** instead of **Level**. If **None** is selected, no volume conversion is performed. Select the vessel shape matching the monitored vessel or reservoir.

Options	* None
	Flat Level Bottom
	Conical Bottom
	Parabolic Bottom
	Half Sphere Bottom
	Flat Sloped Bottom
	Flat Ends
	Parabolic Ends
	Sphere
	Universal Linear
	Universal Curved

See page 134 for illustrations. If Universal Linear or Universal Curved is selected, enter values for level and volume breakpoints after completing the wizard (see page 137).

A vessel shape must be selected to proceed through the QS Volume Wizard.

Units

Sensor measurement units.

Options	*M (meters)
	CM (centimeters)
	MM (millimeters)
	FT (feet)
	IN (inches)

Note: For the purpose of this example, all values are assumed to be in meters.

Empty

Sets the distance from the face of the transducer to the process empty point.

Index	Level
Values	Range: 0.000 to 99.000 m
	Preset: 5.000 m

Span

Sets the range to be measured.

Index	Level
Options	Range: 0.000 to 99.000 m (or equivalent, depending on 2.1.1. Units)
	Preset: based on 2.2.4. Empty

Response Rate

Sets the reaction speed of the device to measurement changes in the target range.

Notes:

- Any changes made to 2.3.2. Fill Rate/minute or 2.3.3. Empty Rate/minute parameters following the completion of the wizard will supersede the Response Rate setting.
- Response Rate always displays in meters per minute (m/min).

Index	Transducer
Options	Slow (0.1 m/min)
	*Medium (1.0 m/min)
	Fast (10.0 m/min)

Use a setting just faster than the maximum filling or emptying rate (whichever is greater). Slower settings provide higher accuracy, faster settings allow for more rapid level fluctuations.

Dimension A

The height of the vessel bottom when the bottom is conical, pyramidal, parabolic, spherical, or flat -sloped.

Dimension A as used in Parameter 2.7.2. Vessel Shape.

Index	Level
Values	Range: 0.0 to 99.00 m or equivalent, depending on 2.1.1. Units
	Preset: 0.000

Enter one of the following:

- Height of the tank bottom, if 2.7.2. *Vessel Shape* = Conical Bottom, Parabolic Bottom, Half Sphere Bottom, or Flat Sloped Bottom
or
- Length of one end section of the tank, if 2.7.2. *Vessel Shape* = Parabolic Ends , in 2.1.1. *Units*.

Dimension L

Length of the cylindrical section of a horizontal parabolic end vessel.

Dimension L as used in 2.7.2. *Vessel Shape*.

Index	Level
Values	Range: 0.0 to 99.00 m or equivalent ,depending on 2.1.1. <i>Units</i>
	Preset: 0.000

Enter: Tank length (excluding both end sections) if 2.7.2. *Vessel Shape* = Parabolic Ends.

Maximum Volume

The maximum volume of the vessel.

Enter the vessel volume corresponding to 2.2.2. *Span*. For example, if your maximum vessel volume is 8000 L, enter a value of 8000.

For readings in volumetric units (rather than percent), enter the equivalent vessel volume for 2.2.2. *Span*.

Index	Level
Values	Range: 0.000 to 99999
	Preset: 100.0

Any volume units can be chosen because volume is calculated from empty to maximum span, and is scaled according to the 2.7.2. *Vessel Shape* value.

Note: Make sure the selected units allow LCD volume display.

Examples:

- If max. volume = 3650 m³, enter 3650
- If max. volume = 267500 gallons, enter 267.5 (thousands of gallons)

Configure another measurement point

Gives option to configure more measurement points or end the wizard.

Note: This is available on the dual-point model only.

Options	YES	Returns to the Measurement Point menu.
	NO	Completes the QS Volume configuration.

End of QS Volume Wizard

For QS to be successful, all changes must be applied.

Options	BACK, CANCEL, FINISH (Display returns to 1.1 Quick Start menu when Quick Start is successfully completed or cancelled. If CANCEL is selected, no changes are written to the device.)
----------------	-----------------------------------------------------------------------------------------------------------------------------------------------------------------------------------------

To transfer Quick Start values to the device and return to PROGRAM menu, press

DOWN arrow ▼ (Finish). Then press **LEFT arrow ◀** three times to return to Measurement mode.

1.1.3. QS Flow

Use this wizard to configure simple Flow applications.

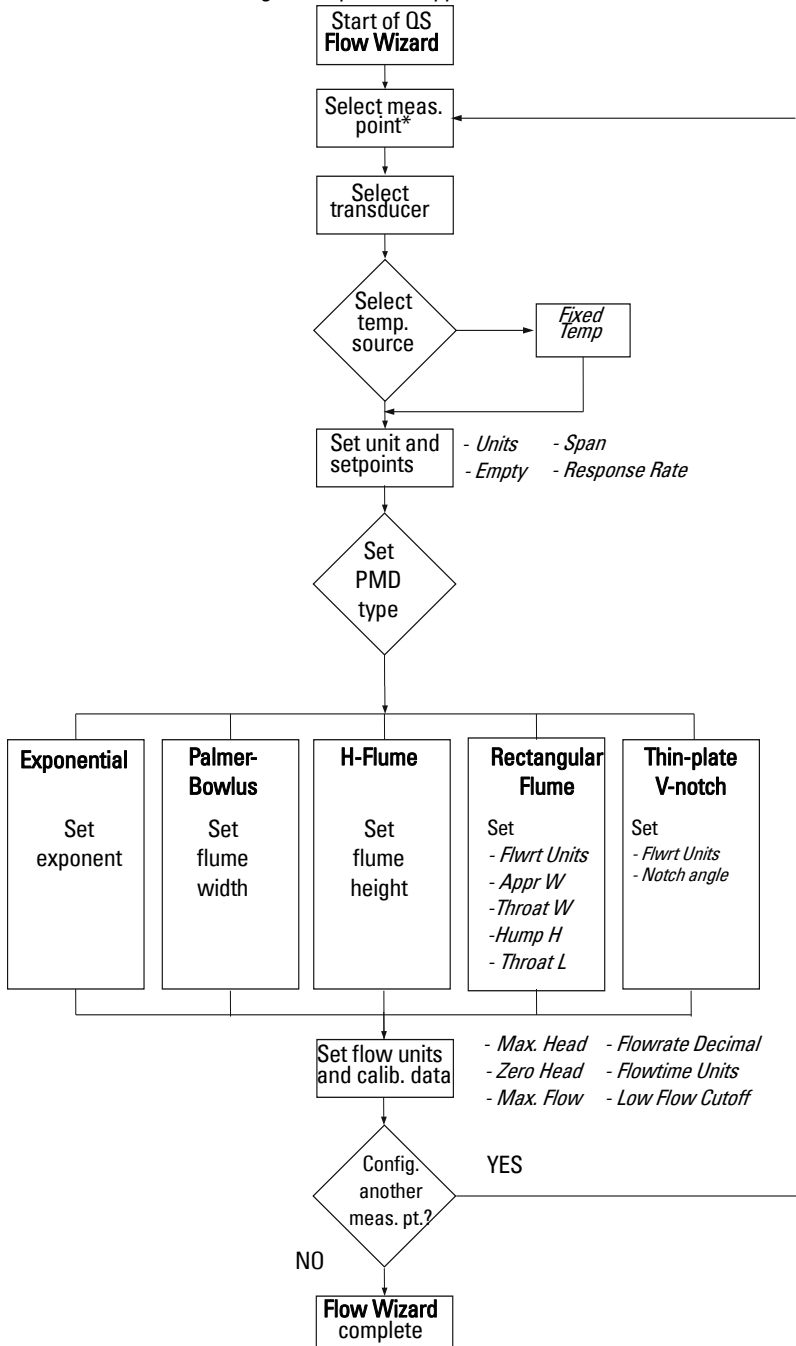

*Available only on dual-point models.

Start of QS Flow Wizard

Shows the type of Wizard to be executed.

Options	CANCEL
	START

Measurement Point Selector

Selects the measurement points to configure.

Note: This is available on the dual-point model only.

Options	Point 1
	Point 2

Transducer

Specifies the model of the Siemens transducer connected to the device.

Index	Single-point model	Dual-point model
		Global
Options	*No transducer (dual-point preset)	
	ST-25	
	ST-50	
	STH	
	XCT-8	
	*XPS-10 (single-point preset)	
	XCT-12	
	XPS-15	
	XRS-5	
	mA input	

Temperature Source

Source of the temperature reading used to adjust the speed of sound.

Index	Transducer
Options	*AUTO
	Fixed Temperature
	Transducer
	External TS-3
	Average of Sensors

See 2.11.1.4. *Temperature Source* on page 157 for more information.

Fixed Temperature

Sets the temperature of the source when there is no temperature-sensing device connected.

This parameter only displays if Fixed Temperature is selected for Temperature Source.

Value	Range: -100.0 to +150.0 °C
	Default: +20.0 °C

Units

Sensor measurement units.

Options	*M (meters)
	CM (centimeters)
	MM (millimeters)
	FT (feet)
	IN (inches)

Note: For the purpose of this example, all values are assumed to be in meters.

Empty

Sets the distance from the face of the transducer to the process empty point.

Index	Level
Values	Range: 0.000 to 99.000 m
	Preset: 5.000 m

Span

Sets the range to be measured.

Index	Level
Options	Range: 0.000 to 99.000 m (or equivalent, depending on 2.1.1. Units)
	Preset: based on 2.2.4. Empty

Response Rate

Sets the reaction speed of the device to measurement changes in the target range.

Notes:

- Response Rate can only be set through the Quick Start Wizard, and any changes made to 2.3.2. Fill Rate/minute or 2.3.3. Empty Rate/minute parameters following the completion of the wizard will supersede the Response Rate setting.
- **Response Rate** always displays in meters per minute (m/min).

Index	Transducer
Options	Slow (0.1 m/min)
	*Medium (1.0 m/min)
	Fast (10.0 m/min)

Use a setting just faster than the maximum filling or emptying rate (whichever is greater). Slower settings provide higher accuracy, faster settings allow for more level fluctuations.

Primary Measuring Device

The type of primary measuring device (PMD) used.

Index	Single-point model Dual-point model
--------------	---------------------------------------------------

Options¹	Global	Transducer
	OFF	
	Exponential devices	(see 2.13.4.1. Flow Exponent on page 175)
	Palmer-Bowlus Flume	(see 2.13.5. PMD Dimensions on page 180)
	H-Flume	(see 2.13.5. PMD Dimensions on page 180)
	Rectangular Flume BS-3680	(see 2.13.5. PMD Dimensions on page 180)
	Thin Plate V-Notch Weir BS-3680	(2.13.5. PMD Dimensions on page 180)

¹:Option will be set to **Other** if the wizard was run previously and the device was set to **OFF** or **Universal Head Vs. Flow**. If this is the initial configuration, the PMD can only be set for no calculation (OFF), or for linearization (Universal Head vs. Flow).

Flow Exponent

(Primary Measuring Device = Exponential devices)

The exponent for the flow calculation formula.

Values	Range: -999.000 to 9999.000
	Default: 1.550

Flowrate Units

(Primary Measuring Device = Rectangular Flume BS-3680 or Thin Plate V-Notch Weir BS-3680)

The units used for flow calculations.

Note: Shown only when 2.13.2. Primary Measuring Device = Rectangular Flume BS-36806 or Thin Plate V-Notch Weir BS-36807.

Index	Single-point model		Dual-point model	
	Global		Transducer	
Options	Ratiometric (2.13.2. Primary Measuring Device = all)		*Ratiometric calculation	
	Absolute (2.13.2. Primary Measuring Device = Rectangular Flume BS-3680 or Thin Plate V-Notch Weir BS-3680 only)		L/S (Liters/second)	
			M ³ /H (Cubic meters/hour)	
			M ³ /D (Cubic meters/day)	
			FT ³ /S (Cubic feet/second)	
			IMPGAL/MIN (Gallons/minute – Imperial)	
			MIMPGAL/D (Million gallons/day – Imperial)	
			GAL/MIN (Gallons/minute – U.S.)	
MUSGAL/D (Million gallons/day – U.S.)				

V-Notch Angle

(Primary Measuring Device = Thin Plate V-Notch Weir BS-3680)

The V-Notch angle used in the flow calculation formula.

Values	Range: 25.000 to 95.000
	Default: 25.000

Use this parameter if the Primary Measuring Device is directly supported. The dimensions required for each PMD vary.

PMD Dimensions

The dimensions of the Primary Measuring Device (PMD).

Notes:

- For each PMD excluding *Exponential Devices*, (see *Primary Measuring Device* on page 174), you must enter up to four dimensions.
- In the wizard, you will be prompted for each dimension required for the PMD selected, and the respective PMD dimension name will be displayed.

Index	Single-point model	Dual-point model
		Global
Index values for supported PMDs	Dimension name (parameter menu reference)	
	Palmer-Bowlus	
	Flume width (2.13.5.1. OCM Dimension 1)	
	H-Flume	
	Flume height (2.13.5.1. OCM Dimension 1)	
	Rectangular Flume BS-3680/ISO 4359	
	Approach width B (2.13.5.1. OCM Dimension 1)	
	Throat width b (2.13.5.2. OCM Dimension 2)	
	Hump height P (2.13.5.3. OCM Dimension 3)	
	Throat Length L (2.13.5.4. OCM Dimension 4)	
	Velocity coefficient (2.13.5.5. OCM Dimension 5), Read only	
	Discharge coefficient (2.13.5.6. OCM Dimension 6), Read only	
	Thin Plate V-Notch Weir	
	Notch angle (2.13.5.1. OCM Dimension 1)	
	Discharge coefficient (2.13.5.2. OCM Dimension 2), Read only	

Maximum Head

The level value associated with Maximum Flow, in 2.1.1. Units.

Index	Single-point model	Dual-point model
		Global
Values	Range: -999 to 999999	
	Preset: 2.2.2. Span value	

This represents the highest head level supported by the PMD and works in conjunction with 2.13.4.3. *Maximum Flow* to define the highest point in the exponential curve. Use it when the PMD requires a maximum head and flow reference point. This would include Exponential, Palmer-Bowlus Flume, H-Flume, and Universal breakpoints.

Zero Head

The distance above 2.2.4. Empty, in 2.1.1. Units representing zero head (and zero flow).

Index	Single-point model	Dual-point model
	Global	Transducer
Values	Range: -999 to 9999	
	Preset: 0.000	

This feature can be used for most weirs and some flumes (e.g. Palmer-Bowlus) where the zero reference is at a higher elevation than the channel bottom

Maximum Flow

The maximum flowrate associated with 2.13.4.2. Maximum Head.

Index	Single-point model	Dual-point model
	Global	Transducer
Values	Range: -999 to 9999	
	Preset: 1000	

This represents the flow at the highest head level supported by the PMD and works in conjunction with 2.13.4.2. Maximum Head to define the highest point in the exponential curve. Use it when the PMD requires a maximum head and flow reference point. This would include Exponential, Palmer-Bowlus Flume, H-Flume, and Universal breakpoints.

Also, use this parameter with 2.13.4.4. Flow Time Units to define the flowrate units. The limitation of four digits is for the LCD only, and the flowrate value is available with greater precision through communications.

Notes:

- The display of the measured value is limited to six digits. A Maximum Flow value larger than seven characters will not display correctly.
- If measured value is larger than seven characters, the screen displays ####. A larger unit (2.13.4.4. Flow Time Units) should be used, or number of decimal points (2.13.4.6. Flowrate Decimal) should be reduced.

Flowrate Decimal

The maximum number of decimal places to be displayed.

Index	Single-point model	Dual-point model
	Global	Transducer
Options	No digits	
	1 digit	
	*2 digits	
	3 digits	

In RUN mode, the number of decimal places displayed is automatically adjusted (if necessary) to prevent the number of Flowrate digits from exceeding display capabilities.

The maximum number of head decimal places is controlled by 2.12.4. *Decimal Position*.

Flow Time Units

Defines the units used to display current flow and logging flow values.

Index	Single-point model	Dual-point model
		Global
Options	Seconds	
	Minutes	
	Hours	
	*Days	
Altered by	2.13.4.7. <i>Flowrate Units</i>	

This is used when the Primary Measuring Device is **Ratiometric** (2.13.4.7. *Flowrate Units*= Ratiometric).

Example:

Conditions	Enter
Flowrate display: millions of gallons/day, maximum flowrate is 376,500,000 gallons/day	376.5 for 2.13.4.3. <i>Maximum Flow</i> and Days for 2.13.4.4. <i>Flow Time Units</i>

Low Flow Cutoff

Eliminates totalizer activity for flows at, or below the cutoff value.

Index	Single-point model	Dual-point model
		Global
Values	Range: 0.000 to 9999	
	Preset = 5.000 %, in equivalent units	

Use this to enter the minimum head in 2.11. *Units*.

Configure another measurement point

Gives option to configure more measurement points or end the wizard.

Note: This is available on the dual-point model only.

Options	YES	Returns to the Measurement Point menu.
	NO	Completes the QS Flow configuration.

End of QS Flow Wizard

For QS to be successful, all changes must be applied.

Options	BACK, CANCEL, FINISH (Display returns to 1.1 Quick Start menu when Quick Start is successfully completed or cancelled. If CANCEL is selected, no changes are written to the device.)
---------	-----------------------------------------------------------------------------------------------------------------------------------------------------------------------------------------

To transfer Quick Start values to the device and return to PROGRAM menu, press **DOWN arrow ▼ (Finish)**. Then press **LEFT arrow ◀** three times to return to Measurement mode.

Note: It is strongly recommended that an Auto Zero Head be performed after completion of the wizard to ensure best accuracy. See *2.13.3. Auto Zero Head on page 175*.

1.2. Pump Control

Use this wizard to configure pumps if they will be used in your application. First, be sure to complete the applicable Quick Start Wizards.

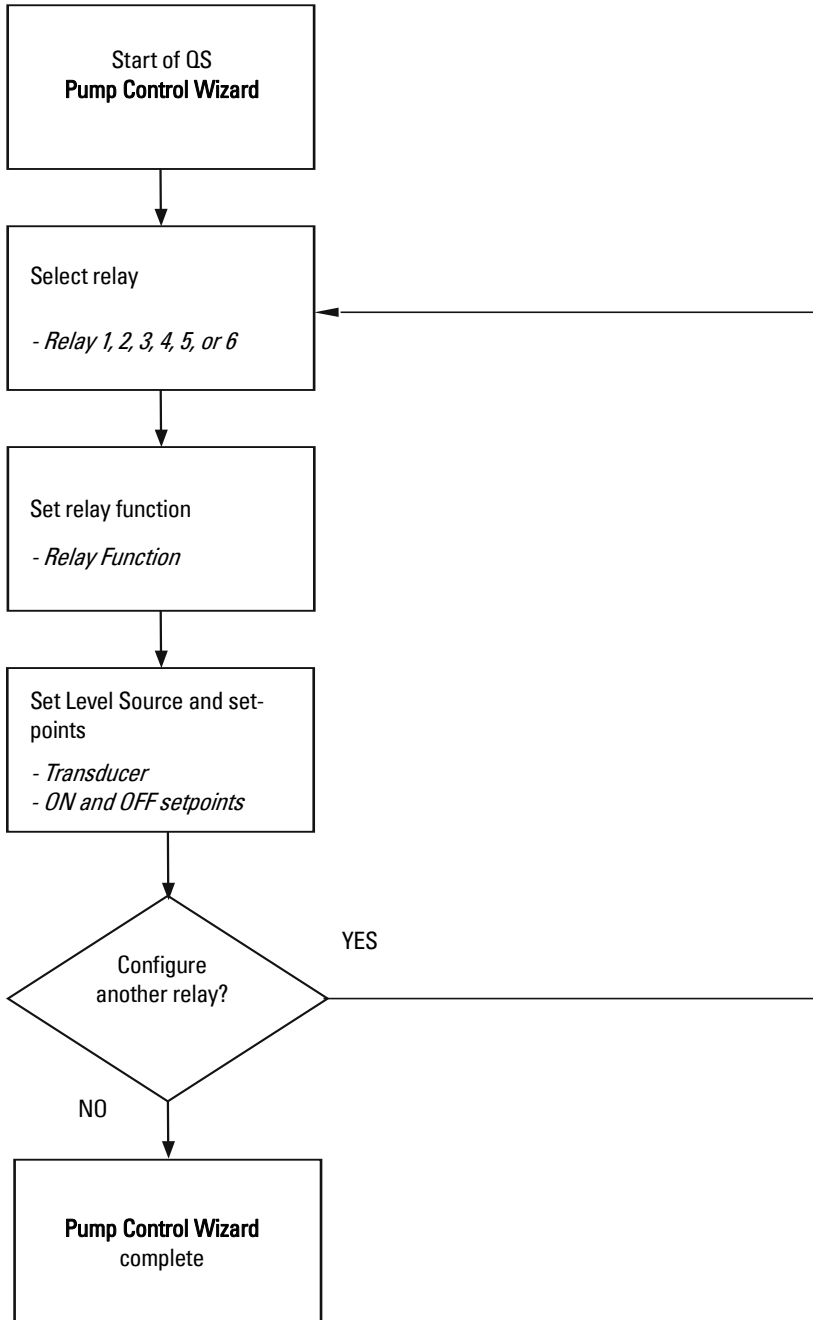

Start of QS Pump Control Wizard

Shows the type of Wizard to be executed.

Options	CANCEL
	START

Relay Selector

Selects the relay to be configured.

Options	*Relay 1
	Relay 2
	Relay 3
	Relay 4
	Relay 5
	Relay 6

Relay Function

Sets the pump function for the relay.

Options	Fixed Duty Assist
	Fixed Duty Backup
	Alternate Duty Assist
	Alternate Duty Backup
	Service Ratio Duty Assist
	Service Ratio Duty Backup
	First In First Out

See 2.8.1.4. Relay Function on page 141 for more details.

Level Source

Sets the level source for the indexed relay.

Index	Relays
Options	*Point 1
	Point 2
	Point 3

See 2.8.1.2. Level Source on page 140 for more details.

Service Ratio

Selects pump usage based on the RUN time ratio rather than last used.

Value	Range: 0 to 255
	Default: 1

This parameter displays only if a Service Ratio algorithm is selected for Relay Function.

Pump Hours

Sets the amount of time that pump relay has run, defined in hours.

Index	Relay
Values	Range: 0 to 999999

This parameter displays only if a Service Ratio algorithm is selected for Relay Function.

ON Setpoint

*Sets the process point at which the relay changes from its **Normal** state.*

Index	Relay
Values	Range: -999 to 9999
	Preset: ----

For most applications, the relay is tripped at this point. This parameter is set according to 2.2.2. *Span* even when another reading, such as volume, is shown on the LCD.

OFF Setpoint

*Sets the process point at which the relay returns to its **Normal** state.*

Index	Relay
Values	Range: -999 to 9999
	Preset: ----

For most applications, the relay is reset at this point. This parameter is set to 2.2.2. *Span*, even when another reading, such as volume, is shown on the LCD.

Configure another relay

Gives option to configure more relays or end the wizard.

Options	YES	Returns to the Relay Function menu.
	NO	Completes the QS Pump Control configuration.

End of QS Pump Control Wizard

For QS to be successful, all changes must be applied.

Options	BACK, CANCEL, FINISH (Display returns to 1.1 Quick Start menu when Quick Start is successfully completed or cancelled. If CANCEL is selected, no changes are written to the device.)
----------------	-----------------------------------------------------------------------------------------------------------------------------------------------------------------------------------------

To transfer Quick Start values to the device and return to PROGRAM menu, press

DOWN arrow ▼ (Finish). Then press **LEFT arrow ◀** three times to return to Measurement mode.

Application examples

In the examples that follow, substitute your own application details. If the examples are not suitable to your application, check the relevant parameter references for other available options.

Level application

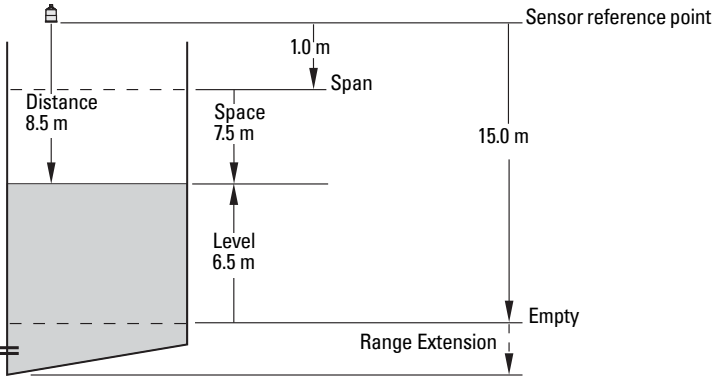

Quick Start Parameter	Setting	Description
Transducer	XPS-15	Transducer to be used with the HydroRanger.
Operation	Level	Material level referenced from Low Cal. Point.
Temperature Source	TS-3	Temperature source.
Units	m	Sensor measurement units.
Empty	15.0	Process empty level.
Span	1.0	Process full level.
Response Rate	Slow	Sets Fill Rate ¹ / Empty Rate to 0.1 m/minute.

¹ See 2.3.2. Fill Rate/minute on page 124.

The application is a vessel that takes an average 3 hours (180 minutes) to fill and 3 weeks to empty.

$$\begin{aligned} \text{Fill rate} &= (\text{Empty} - \text{Span}) / \text{fastest of fill or empty time} \\ &= (15.5 \text{ m} - 1 \text{ m}) / 180 \text{ min.} \\ &= 14.5 \text{ m} / 180 \text{ min.} = 0.08 \text{ m/min.} \end{aligned}$$

Flow application

Parshall Flume

In this example, a 12-inch (0.305 m) Parshall Flume has been installed in an open channel. As per the supplier's data sheet, the device has been rated for a maximum flow of 1143 m³ per hour at a maximum head of 0.6 m.

The Parshall Flume is considered an exponential device, therefore the supplier's data sheet includes a flow exponent value of 1.522.

The HydroRanger 200 HMI, and the XRS-5 transducer have been installed 1.6 m above the channel beside the TS-3 external temperature sensor.

During intermittent peak flow times, the head level can be expected to rise at a rate of approximately 0.12 m/min. The application also calls for a flow sampler to be activated every 1000 m³, or 24 hours (whichever comes first), and for a fail-safe alarm to activate in the event of a loss of echo or cable fault.

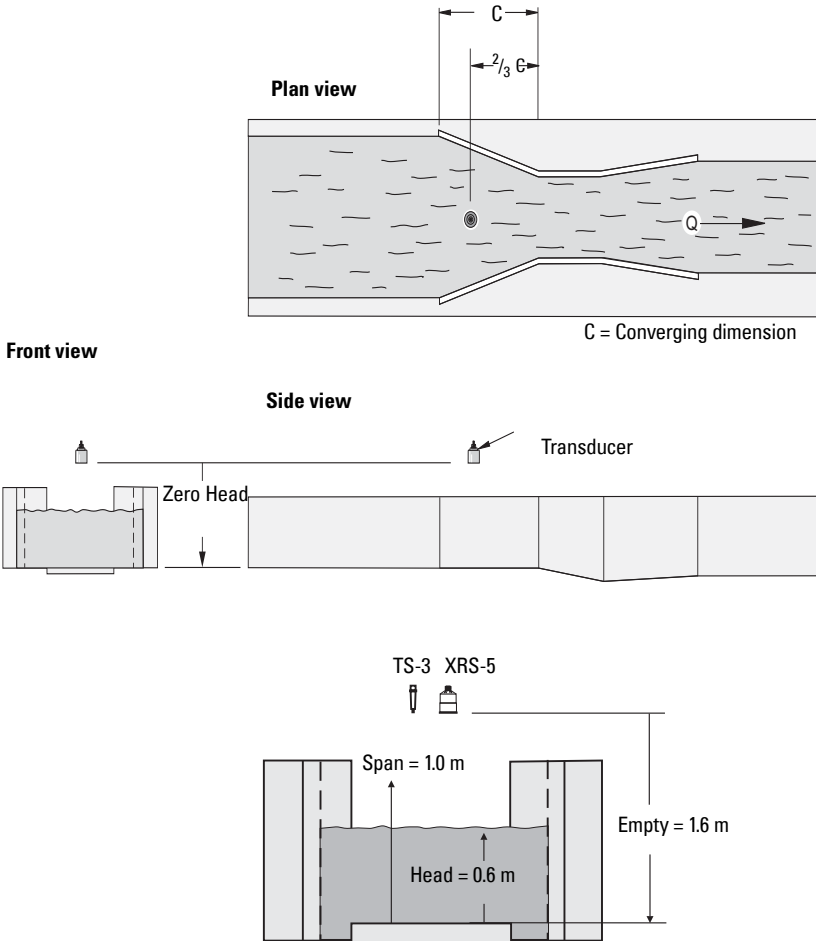

General operation

This chapter provides details on the general operation and functionality of the HydroRanger 200 HMI. For instructions on the use of the device LCD and local push buttons, refer to *The LCD Display* on page 25.

Note: Power up display

- Single-point model
 - Preset to display distance from the face of the transducer to the material.
 - Transducer selection is preset for the XPS-10.
 - Empty distance is preset to 5 m (meters).
- Dual-point model
 - Starts in an OFF state and does not take **Level** measurements.
 - To set up measurement, the quick start parameters must be configured.
 - See *Quick Start Wizards* on page 31.

Note: The number of points is an order option and is set by the factory. On a single-point model, the index for *2.1.3. Sensor Mode* is Global. On a dual-point model, the index for *2.1.3. Sensor Mode* is 1 or 2. (See *The LCD Display* on page 25 for the index number location)

Single-point models

The HydroRanger 200 HMI starts in **Distance** mode with the transducer preset for the XPS-10 and an empty distance of 5 meters. Change the following parameters to reflect your application parameters.

Parameter	Index	Value/Mode	Description
<i>2.1.3. Sensor Mode</i>	Global	*Level	Operation = *Level
<i>2.1.6. Material</i>	Global	Liquid	Material = *Liquid
<i>2.3.4. Response Rate</i>	Global	Medium	Maximum Process Speed= *Medium (1.0 m/min)
<i>2.1.5. Transducer</i>	Global	XPS-15	Read only = XPS-15
<i>2.1.1. Units</i>	Global	Meters	Units = Meters
<i>2.2.4. Empty</i>	Global	12	Empty = 12 m
<i>2.2.2. Span</i>	Global	10	Span = 10 m

Average or differential

For differential or average operation with a single-point HydroRanger 200 HMI, set Operation to *2.1.3. Sensor Mode* = Dual-Point Difference (differential) or Dual-Point Average (average) and connect two transducers of the same type. All of the relevant parameters then become indexed by the correct transducer:

Index	Description
2	Indexed by Transducer 1 or 2
3	Indexed by Level measurement 1 = Transducer 1 2 = Transducer 2 3 = Calculated Level (average or difference)

Dual-point models

The HydroRanger 200 HMI starts in an OFF state and does not take **Level** measurements. For measurement setup, configure these basic parameters:

If the application uses two Level Points, provide the basic information for each point separately.

Parameter	Index	Value/ Mode	Description
<i>2.1.3. Sensor Mode</i>	1	*Level	Operation = *Level
	2	*Distance	Operation = *Distance
<i>2.1.6. Material</i>	1	Liquid	Material = *Liquid
	2	Liquid	
<i>2.3.4. Response Rate</i>	1	Medium	Max. Process Speed = *Medium (1.0 m/min)
	2	Fast	Max. Process Speed = Fast (10.0 m/min)
<i>2.1.5. Transducer</i>	1	XPS-15	Transducer = XPS-15
	2	XPS-10	Transducer = XPS-10 (single-point preset)
<i>2.1.1. Units</i>	Global	Meters	Units = Meters
<i>2.2.4. Empty</i>	1	12	Empty = 12 m
	2	4	Empty = 4 m
<i>2.2.2. Span</i>	1	11	Span = 11 m
	2	3.5	Span = 3.5 m

Average or differential

For differential or average operation dual-point HydroRanger 200 HMI, set Operation to *2.1.3. Sensor Mode* = Dual-Point Difference (differential) or Dual-Point Average (average) and connect two transducers of the same type.

All the relevant parameters are filtered by the transducer selector.

Transducer Selector	Description
2	Indexed by Transducer 1 or 2
3	Indexed by Level measurement
	1 = Transducer 1
	2 = Transducer 2
	3 = Calculated Level (average or difference)

Measurement conditions

The following information will help you configure your HydroRanger 200 HMI for optimal performance and reliability.

Response rate

The response rate of the device influences the measurement reliability. Use the slowest rate possible with the application requirements.

The response rate is also important to functions connected to the filling or emptying indicators.

Dimensions

The dimensions of the vessel, wet well, or reservoir (except empty and span) are only important if you require volume.

Volume is required to report the level value in terms of **Volume**. The pumped volume function can also report pumped volume or pump efficiencies.

Fail-safe indexes

The fail-safe parameters ensure that the devices controlled by the HydroRanger 200 HMI default to an appropriate state when a valid level reading is not available.

- *2.4.2. LOE Timer* – Fail-safe timer activates if an error condition is detected. Upon expiration of the timer, relay status defaults to values based on *2.4.5. Material Level*.
- *2.4.5. Material Level* – Fail-safe material level determines the level reading if the fail-safe timer expires and the unit is still in an error condition.
- *2.8.2.3. Relay Fail-safe* – Relay fail-safe controls the reaction of each relay. See *Relay fail-safe* on page 70 for more information.

If Fail-safe Operation activates frequently, see *Troubleshooting* on page 212.



Relays

Relays are the primary controls of external devices such as pumps or alarms. The HydroRanger 200 HMI comes with extensive functions for relays.

General introduction

The HydroRanger 200 HMI has six relays. Each one may be independently assigned to one function and has a corresponding status icon on the LCD.

The functions fall under three modes of operation:

Mode	Function
Alarm	Alarm ON = LCD Icon ON  = relay coil de-energized
Pump	Pump ON = LCD Icon ON  = relay coil energized
Miscellaneous	Contact closed = LCD Icon ON  = relay coil energized

Relay functions

Each relay on the HydroRanger 200 HMI can be programmed for a wide range of functions according to your application needs. The available function categories are Alarms, Pumps, Totalizing and Sampling, and Miscellaneous.

Setpoint - ON/OFF

If the ON setpoint is higher than the OFF setpoint, the relay operates as:

- High alarm
- Pump down control

If the ON setpoint is lower than the OFF setpoint, the relay operates as:

- Low alarm
- Pump up control

The ON and OFF setpoints can not be the same on an individual relay but may be common to other relays. The dead band or hysteresis is the difference between the ON and OFF setpoints. For in and out of bounds level alarms, the hysteresis is set at $\pm 2\%$ of span from either boundary.

Alarm

Level

In high alarm, the alarm is activated when the level rises to the ON setpoint and turns off when the level lowers to the OFF setpoint. In low alarm, the alarm is activated when the level lowers to the ON setpoint and turns off when the level rises to the OFF setpoint.

In-bounds

The relay will be in alarm if the level is inside the zone between the setpoints.

Out-of-bounds

The relay will be in alarm if the level is outside the zone between the setpoints.

Rate of Change

The filling alarm **activates** when the rate of filling increases to the ON setpoint and **deactivates** when the rate of filling drops to the OFF setpoint.

The emptying alarm **activates** when the rate of emptying increases to the ON setpoint and **deactivates** when the rate of emptying drops to the OFF setpoint. For emptying alarm, the setpoints must be entered as negative values.

Temperature

In high alarm, the function goes on when the temperature rises to the ON setpoint and goes off when the temperature lowers to the OFF setpoint. In low alarm, the function goes on when the temperature lowers to the ON setpoint and goes off when the temperature rises to the OFF setpoint.

Loss of Echo (LOE)

The function starts when the fail-safe timer expires. The function stops when a valid echo is received (fail-safe timer is reset).

Cable Fault

The alarm is activated when a transducer cable is not connected properly (shorted or open).

Pump

Level

In pump down, the function goes on when the level rises to the ON setpoint and goes off when the level lowers to the OFF setpoint. In pump up, the function goes on when the level lowers to the ON setpoint and goes off when the level rises to the OFF setpoint.

Totalizing and Sampling

Refer to *Totalizing pumped volume* on page 91 for more details. Relays are normally de-energized; contact closure is approximately 200 ms duration.

Relay status – Navigation View

When the fail-safe timer expires, pump control relays respond as previously described. However, alarm relays will respond in the following manner:

Fail-safe mode	Relay status	
	High Alarm	Low Alarm
Fail-safe High	ON	OFF
Fail-safe Low	OFF	ON
Fail- safe Hold	HOLD	HOLD

Upon entering the Navigation View, all pump control relays will be turned OFF. Alarm relays will hold their prior status.

Cautions:

- If the relay status can affect plant operation or personnel safety, it is advisable to override the relay functions or disconnect the relay wiring during calibration.
- Keep power disconnected at main breaker when HydroRanger 200 HMI cover is opened.

Relay-related parameters

Some parameters affect how relays react during normal conditions:

Setpoints

When a setpoint is reached, the corresponding action is taken. The setpoint can be an ON or OFF setpoint related to a process variable.

ON and OFF setpoints

Sets the process point at which the relay is activated (ON setpoint) then reset (OFF setpoint). These setpoints are set separately for each pump within each pump control, and for each alarm type.

2.8.1.3. Preset Applications

Sets the HydroRanger 200 HMI to a preset application. These preset applications quickly set up the device with a minimum number of parameters.

2.8.1.4. Relay Function

Sets the default state differently, depending on whether the relay is programmed as an alarm or a control.

The alarm function de-energizes the relay coils. During normal operation (no alarms), the relay coils are energized.

The control function energizes the relay coils. When the instrument is at rest (no controls operating) the relay coils are de-energized.

2.8.1.5. ON Setpoint

Sets the process point at which the relay is activated.

2.8.1.6. OFF Setpoint

Sets the process point at which the relay is de-activated.

2.8.1.11. Relay Logic

Affects relay reaction. Reverses the logic (normally-open to normally-closed or vice versa).

2.8.2.3. Relay Fail-safe

Changes how individual relays react to a failsafe condition on the instrument.

Relay wiring test

3.2.5. Relay Logic Test

Checks the application wiring by forcing a relay control function, such as a level alarm or pump control setpoint. Ensure all the relay programming and wiring works properly.

Please verify that ON and OFF respond correctly. Use this parameter as a final test once all of the relay programming is done.

Relay activation

The flexibility of the relay functions ensures that the HydroRanger 200 HMI can support relay wiring for different systems and applications. Use the following as a guide to the most common parameters.

Relay setpoints and functionality

The setpoint can be an ON or OFF setpoint related to a process variable, or a timed setpoint based on interval and duration.

Functions affected by setpoint are configured by parameters that determine the application requirements such as timing. *2.8.1.4. Relay Function* (page 141) sets the function requirements. Other function parameters:

- *2.8.2.8.1. Delay Between Starts*
- *2.8.2.8.2. Power Resumption Delay*
- *2.10.1.3. Relay Duration*



Relay logic is modified

Normal operating conditions mean that alarm relays are energized and pumps are de-energized. This can be reversed using *2.8.1.11. Relay Logic*.

Preset applications

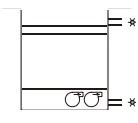
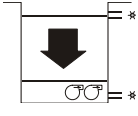
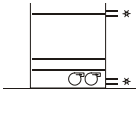
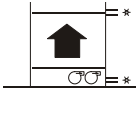
Preset applications set up the relay parameters to predetermined values shown below:

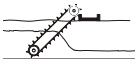
Value	#	Parameters affected						
OFF	0	All relays set to OFF						
Wet Well 1 	1	Pump down with the following settings:						
		Parameter	Relay #					
			1	2	3	4	5	6
		<i>2.8.1.4. Relay Function</i>	Alternate Duty Assist	Alternate Duty Assist	Level (H)	Level (L)	*OFF	*OFF
		<i>2.8.1.5. ON Setpoint</i>	70%	80%	90%	10%	–	–
<i>2.8.1.6. OFF Setpoint</i>	20%	20%	85%	15%	–	–		
Wet Well 2 	2	Pump down with the following level and rate settings:						
		Parameter	Relay #					
			1	2	3	4	5	6
		<i>2.8.1.4. Relay Function</i>	Alternate Duty Assist	Alternate Duty Assist	Level (H)	Level (L)	*OFF	*OFF
		<i>2.8.1.5. ON Setpoint</i>	70%	80%	90%	10%	–	–
		<i>2.8.1.6. OFF Setpoint</i>	20%	20%	85%	15%	–	–
<i>2.8.1.8. Pump by Rate</i>	ON							
<i>2.8.1.8. Pump by Rate</i> sets the pump relays to accept control by rate of level change once the first ON setpoint is reached. Because the pumps are started by rate, you must change <i>2.3.10. Emptying Indicator</i> to desired empty rate.								
Reservoir 1 	3	Pump up with the following level settings:						
		Parameter	Relay #					
			1	2	3	4	5	6
		<i>2.8.1.4. Relay Function</i>	Alternate Duty Assist	Alternate Duty Assist	Level (H)	Level (L)	*OFF	*OFF
		<i>2.8.1.5. ON Setpoint</i>	30%	20%	90%	10%	–	–
<i>2.8.1.6. OFF Setpoint</i>	80%	80%	85%	15%	–	–		
Reservoir 2 	4	Pump up with the following level and rate settings:						
		Parameter	Relay #					
			1	2	3	4	5	6
		<i>2.8.1.4. Relay Function</i>	Alternate Duty Assist	Alternate Duty Assist	Level (H)	Level (L)	*OFF	*OFF
		<i>2.8.1.5. ON Setpoint</i>	20%	20%	90%	10%	–	–
		<i>2.8.1.6. OFF Setpoint</i>	80%	80%	85%	15%	–	–
<i>2.8.1.8. Pump by Rate</i>	ON							
<i>2.8.1.8. Pump by Rate</i> sets the pump relays to accept control by rate of level change once the first ON setpoint is reached. Because the pumps are started by rate, you must change <i>2.3.9. Filling Indicator</i> to desired fill rate.								

Value	#	Parameters affected						
Screen Note: 2.1.3. <i>Sensor Mode</i> must be set to Dual-Point Difference before activating this preset. 	5	Differential control of a screen or rake:						
		Parameter	Relay #					
			1	2	3	4	5	6
		2.8.1.2. <i>Level Source</i>	Difference or average	Transducer 1	Transducer 2	Difference or average	*OFF	*OFF
		2.8.1.4. <i>Relay Function</i>	Fixed Duty Assist	Level (H)	Level (L)	Level (H)	–	–
		2.8.1.5. <i>ON Setpoint</i>	80%	90%	10%	90%	–	–
2.8.1.6. <i>OFF Setpoint</i>	20%	85%	15%	10%	–	–		
Alarms 	6	General alarms at four setpoints:						
		Parameter	Relay #					
			1	2	3	4	5	6
		2.8.1.4. <i>Relay Function</i>	Level (H)	Level (L)	Level (HH)	Level (LL)	*OFF	*OFF
		2.8.1.5. <i>ON Setpoint</i>	80%	20%	90%	10%	–	–
2.8.1.6. <i>OFF Setpoint</i>	75%	25%	85%	15%	–	–		

Relay fail-safe

Adjusts how individual relays react to a fail-safe condition. Relays can be set to:

- OFF Response set by 2.4.5. *Material Level*.
- HOLD Stay at the last-known state.
- ENERGIZE Energizes the relay.
- DE-ENERGIZE De-energizes the relay coil.

Security

The unit can still be put into PROGRAM mode when locked. Parameter values can also be viewed, but they cannot be changed.

When 5.1. *Write Protection* is set, programming is enabled. To disable programming, enter another value.

Parameter types

Read only parameters

Parameter values indicating status only. They cannot be altered.

Global values

Parameter values common to all inputs and outputs on the HydroRanger 200 HMI.

Default values

Parameter default values are indicated with an * in the parameter tables.

Parameter reset

3.2.1. *Master Reset* returns all parameters to factory default values.

Use conditions:

- Before initial system installation.
- Following a software upgrade.

Display readout

The following readouts are shown when the HydroRanger 200 HMI cannot display a number.

Display	Definition
▲ ▲ ▲ ▲	Parameter has not been set.
####	Value too large to display.

Adjusting the Primary Reading:

Parameter	Action
2.12.4. <i>Decimal Position</i>	Sets number of decimals.
2.12.5. <i>Convert Reading</i>	Scales the reading to fit.
2.12.6. <i>Offset Reading</i>	Shifts the reading up or down by a fixed amount.

Example

To reference the displayed level to sea level, enter the distance in 2.1.1. *Units*, between 2.2.4. *Empty* and sea level. (Enter a negative value if Empty is below sea level.)

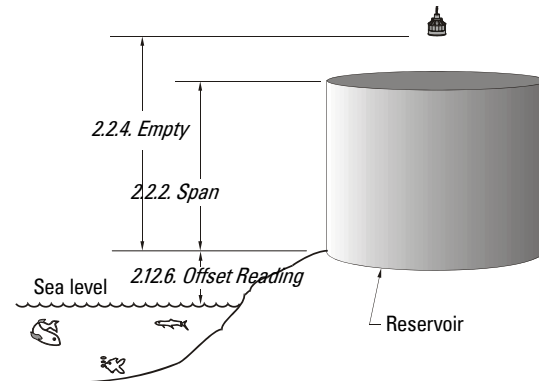

2.12.6. *Offset Reading* is the distance between sea level and Empty.

Backup level override

Backup level override provides the option of overriding the ultrasonic input with another contacting point level device (for example, the Pointek CLS200). The ultrasonic reading is fixed at the programmed switch level until the discrete input is released; the override is then removed, and the HydroRanger 200 HMI returns to normal measurement.

Backup level override parameters

2.9.1.2. Discrete Input Number

Sets the discrete input as the source of a level reading override.

2.9.1.3. Level Override Value

Substitutes value for current reading when *2.9.1.2. Discrete Input Number* is activated. Value is added in current units and is valid only for the following:

- Level
- Space
- Distance
- Difference
- Average modes of operation
- Head level in OCM mode

Example:

A high level backup switch is connected to Digital Input 2 in the same application as Transducer 1 at level value 4.3 m.

Settings

Parameter	Index	Value
<i>2.9.1.2. Discrete Input Number</i>	1	DI 2 Override Signal
<i>2.9.1.2. Discrete Input Number</i>	2	*No Override
<i>2.9.1.3. Level Override Value</i>	1	4.3
<i>2.9.1.3. Level Override Value</i>	2	–

When the level rises to 4.3 m and the switch is activated, the reading is forced to 4.3 m where it stays until the switch is de-activated.

2.9.1.4. Override Time Delay

Sets the time (in seconds) used to calm the override condition input.

Discrete inputs

Discrete input logic affects the reaction of the discrete input. Normal state is the standard operation, with the HydroRanger 200 HMI sensing the material level and controlling the pumps.

Wiring the discrete inputs

The contacts of the signalling device connected to the discrete inputs may be **Normally Open** or **Normally Closed**.

Example:

Normal state for a backup high level switch is open, and the contacts on the discrete input are wired as normally open. This logic can also be reversed (Normally Open to Normally Closed or vice versa).

Use the *2.9.2. Discrete Input Logic* parameters to set the state of each discrete input.

Adjusting the discrete input logic

The default for discrete inputs is **Normally Open**, which is an **Inactive** state because no signal is present on the terminal block connector. It becomes **Active** only when a signal is present on the terminal block. To change between **Inactive** and **Active**, use *2.9.2. Discrete Input Logic*.

mA I/O

To integrate the HydroRanger 200 HMI with other equipment, use the mA input and outputs. The mA input can be used as a **Level** measurement or can be passed on to a SCADA system.

mA Input

Level reading parameters

Parameter	Value	Description
2.1.5. Transducer	mA input	Transducer = mA input
2.6.1. mA Input Range	*4 to 20 mA	Scale = *4 to 20 mA
2.6.2. 0/4 mA Level Value	0	4 mA = 0% of span
2.6.3. 20 mA Level Value	100	20 mA = 100% of span
2.6.4. mA Damp Filter	0	Do not damp the input signal.

To pass the mA input on to a SCADA system, read the value from the appropriate communication registers. For more information, see *Input/Output (R41,070 – R41,143)* on page 254.

mA Output

The HydroRanger 200 HMI has two mA outputs used to send measurements to other devices.

Below are settings for configuring the mA output to send a 4 to 20 mA signal, scaled from 10% to 90% of span, of the second transducer:

Parameter	Index	Value	Description
2.5.2. mA Output Range	1	*4 to 20 mA	Set to *4 to 20 mA range.
2.5.3. Current Output Function	1	Level	Send mA proportional to Level reading.
2.5.4. mA Output Allocation	1	Point 2	Base mA on Level Point 2.
2.5.5. 4 mA Setpoint	1	10	Set 4 mA at 10% of span ¹
2.5.6. 20 mA Setpoint	1	90	Set 20 mA at 90% of span ²
2.4.4. Fail-safe Mode	1	0	Set fail-safe action as 0 mA

1. If the level reading drops below 10% of span, the mA output drops below 4 mA.
2. If the level reading rises above 90% of span, the mA output rises above 20 mA.

Calibrating 4 mA Output

1. Connect the mA receiving device to the HydroRanger 200 HMI.
2. Put the HydroRanger 200 HMI into Navigation View.
3. Set *2.5.9. Milliamp Output* to 4.0 for the selected mA output.
4. View the mA level on the receiving device.
5. If there is a discrepancy, do the following steps:
 - a. Attach an ammeter to HydroRanger 200 HMI mA output.
 - b. Enter the exact value displayed on the ammeter into *2.5.11. 4 mA Output Trim*.
 - c. The ammeter should then read exactly 4.00 mA.

The unit is now calibrated for 4 mA for the receiving device.

Calibrating 20 mA Output

1. Connect the mA receiving device to the HydroRanger 200 HMI.
2. Put the HydroRanger 200 HMI into Navigation View.
3. Set *2.5.9. Milliamp Output* to 20.0 for the selected mA output.
4. View the mA level on the receiving device.
5. If there is a discrepancy, do the following steps:
 - a. Attach an ammeter to HydroRanger 200 HMI mA output.
 - b. Enter the exact value displayed on the ammeter into *2.5.12. 20 mA Output Trim*.
 - c. The ammeter should then read exactly 20.00 mA.

The unit is now calibrated for 20 mA for the receiving device.

Volume

Volume is used in two situations:

1. Calculate and display **Volume** instead of **Level**.
2. Calculate pumped volume to accomplish the following:
 - Totalize the volume of material that is pumped out of the wet well.
 - Set an alarm on pump efficiency.

Readings

When using volume, volume values are presented in the same units specified in *2.7.3. Maximum Volume*.

The default is 100, which gives a reading in percent of total. Use whatever unit is applicable. If the value is too large for the six-digit LCD, use a larger unit.

Vessel shape and dimensions

The HydroRanger can be configured to suit many common vessel or tank shapes. (See *2.7.2. Vessel Shape* on page 134. Whenever possible, use one of those pre-defined selections.) Each shape uses the Empty distance (*2.2.4. Empty*) in its calculations of volume.

Some tank shapes also require extra dimensions to calculate the volumes. Do not estimate these values as they must be exact to ensure the accuracy of your volume calculations.

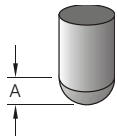

To configure volume for a tank with a half-sphere bottom, set the following:

Parameter	Index	Mode/Value	Description
<i>2.7.2. Vessel Shape</i>	1	Half Sphere Bottom	Selects the correct tank shape
<i>2.7.3. Maximum Volume</i>	1	100	Sets maximum volume at 100 (percent).
<i>2.7.4. Dimension A</i>	1	1.3	Sets A to 1.3 m

Notes:

- The default reading changes to a range from 0 to 100 (the value in *2.7.3. Maximum Volume*).
- Empty (*2.2.4. Empty*) is still measured to the bottom of the tank, not the top of **A**.

Characterization chart

If you cannot use a pre-defined tank, then use one of the universal tank shapes and program the characterization curve.

1. Plot a volume-to-height chart. Usually, a tank supplier provides this chart. However, for custom-built wet wells, you need to have the complete drawings of the well or its accurate measurements.
2. Enter the curve values from this chart into the Volume tables under 2.7.8. Table 1-8, 2.7.9. Table 9-18, 2.7.10. Table 17-24, and 2.7.11. Table 25- 32.
3. Ensure extra points are added around sharp transitions in the wet well volume (for example, as steps in the well wall).

Note: The end points in the curve are 0,0 (fixed) and the point defined by 2.2.2. Span and 2.7.3. Maximum Volume.

Example chart

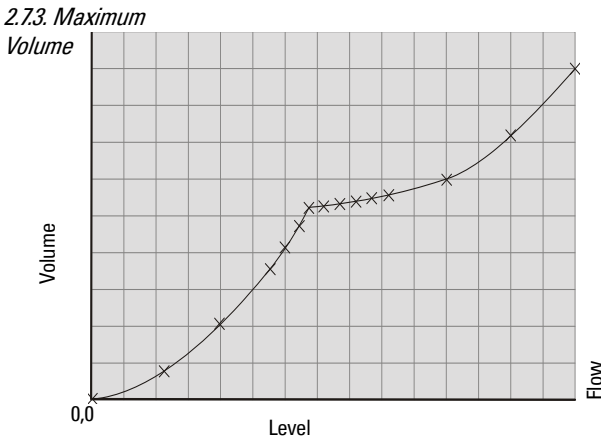

Parameter	Transducer Selector ¹	Value	Description
3.2.6.3. Level	1	0.0	Determines the Level breakpoints at which the volumes are known.
		0.8	
		2.0	
		3.5	
		4.1	
		4.7	
		5.1	
		5.2	
		5.3	
		5.4	
		5.5	
		5.6	
		6.0	
		7.2	
9.0			
3.2.6.13. Head	1	0.0	Determines the volumes which correspond to the level breakpoints. The universal calculations interpret between the breakpoints to produce an accurate model of the volume at all level readings. Settings 2.7.2. Vessel Shape = Universal Linear (for linear approximation) 2.7.2. Vessel Shape = Universal Curved (for curved approximation) Linear approximation uses a linear algorithm; curved approximation uses a cubic spline algorithm.
		2.1	
		4.0	
		5.6	
		5.9	
		6.3	
		6.7	
		7.1	
		7.8	
		8.2	
		8.8	
		9.2	
		10.9	
		13.0	
15.0			

1. To configure the breakpoint table for Level Point 1, set the Transducer Selector to 1. Enter the appropriate Level and Volume values into the menus <x.y.z> and <x.y.t> where x.y.z refers to Level and x.y.t refers to Volume.

Alarms

Level

The level alarm is the most common. Use this alarm to warn you when the process is in danger of being upset due to high or low levels.

Generally, the four alarms used are Hi, Hi-Hi, Lo, and Lo-Lo.

Set the common parameters

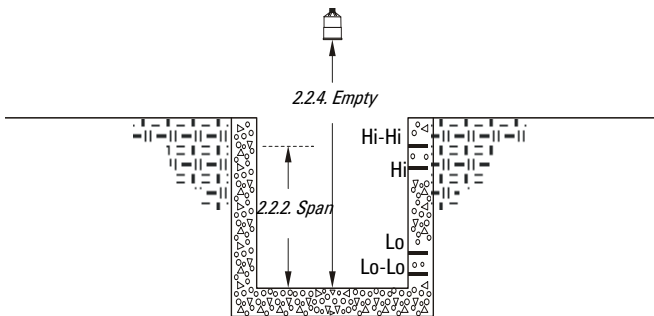

Prerequisite: You must know the details of your application and substitute the values for the sample values provided. If you are bench testing the unit, set your test values to be the same as the sample values.

Parameter	Index ¹	Value	Description
2.1.3. Sensor Mode	Global	*Level	Operation = *Level
2.1.6. Material	Global	Liquid	Material = *Liquid
2.3.4. Response Rate	Global	Medium	Maximum Process Speed = *Medium (1.0 m/min)
2.1.5. Transducer	Global	XPS-10	Transducer = XPS-10 (single-point preset)
2.1.1. Units	Global	Meters	Units = Meters
2.2.4. Empty	Global	1.8	Empty = 1.8 m
2.2.2. Span	Global	1.4	Span = 1.4 m

1. This example assumes a base, single measurement unit. If your unit has optional dual-point software installed, then some parameters are indexed by two level points.

Setting simple level alarms

Set 2.8.1.1. *Relay Selector* to Relay 5 and set the other parameters according to the table below:

Parameter	Index	Mode/Value	Description
2.8.1.2. <i>Level Source</i>	5	Trans. 1	Set 2.8.1.2. <i>Level Source</i> , indexed to relay, to option Transducer 1.
2.8.1.4. <i>Relay Function</i>	5	Level	Set 2.8.1.4. <i>Relay Function</i> , indexed to relay, to option Level for level alarm. Choose H, HH, L, or LL from the list of available designations, below.
2.8.1.5. <i>ON Setpoint</i>	5	1.2 m	Set the ON setpoint
2.8.1.6. <i>OFF Setpoint</i>	5	1.15 m	Set the OFF setpoint

Rate

Rate alarms can trigger an alarm if the vessel is filling/emptying too quickly.

Setting a Filling Rate Alarm

Parameter	Index	Mode/Value	Description
2.8.1.4. <i>Relay Function</i>	5	Rate of Change	These settings trip the alarm when the reservoir is filling faster than 1 m per minute, and reset it at 0.9 m per minute.
2.8.1.5. <i>ON Setpoint</i>	5	1 m	
2.8.1.6. <i>OFF Setpoint</i>	5	0.9 m	

Setting an Emptying Rate Alarm

Parameter	Index	Mode/Value	Description
2.8.1.4. <i>Relay Function</i>	5	Rate of Change	These settings trip the alarm when the reservoir is emptying faster than 1 meters per minute, and reset the alarm when emptying falls to -0.5 meters per minute.
2.8.1.5. <i>ON Setpoint</i>	5	-1 m	
2.8.1.6. <i>OFF Setpoint</i>	5	-0.5 m	

In-bounds/Out-of-bounds Range

Use the bounded range alarms to detect when the level is inside or outside the range. By using a bounded range alarm, you can effectively put two level alarms (high and low) on one relay.

Setting an Out-of-bounds Alarm

Parameter	Index	Mode/Value
2.8.1.4. Relay Function	5	Out-of-bounds
2.8.1.5. ON Setpoint	5	1.3
2.8.1.6. OFF Setpoint	5	0.3
2.8.2.5. Relay Dead Band	5	0.05

Results:

- Trips alarm above 1.35 m and below 0.25 m.
- Resets alarm below 1.25 m and above 0.35 m.

Setting an In-bounds Alarm

Parameter	Index	Mode/Value
2.8.1.4. Relay Function	5	In-bounds
2.8.1.5. ON Setpoint	5	1.3
2.8.1.6. OFF Setpoint	5	0.3
2.8.2.5. Relay Dead Band	5	0.05

Results:

- Trips alarm below 1.25 m and above 0.35 m.
- Resets alarm above 1.35 m and below 0.25 m.

Cable fault

Activates an alarm if transducer cable circuit enters a shorted or opened state.

Parameter	Index	Mode/Value	Description
2.8.1.4. Relay Function	5	Cable Fault	Alarm on transducer cable fault.
2.8.1.2. Level Source	5	Transducer 1	Alarm on Transducer 1.

Temperature

Use the temperature alarm to activate an alarm when the temperature reaches the **ON** setpoint (2.8.1.5. *ON Setpoint*). This alarm uses the same setpoint parameters as the level alarms (2.8.1.5. *ON Setpoint* and 2.8.1.6. *OFF Setpoint*).

You can set a high alarm (2.8.1.5. *ON Setpoint* > 2.8.1.6. *OFF Setpoint*) or a low alarm (2.8.1.5. *ON Setpoint* < 2.8.1.6. *OFF Setpoint*).

This shows a high alarm:

Parameter	Index	Mode/ Value	Description
<i>2.8.1.4. Relay Function</i>	5	Temperature	Alarm on temperature.
<i>2.8.1.5. ON Setpoint</i>	5	45	ON setpoint at 45 °C.
<i>2.8.1.6. OFF Setpoint</i>	5	43	OFF setpoint at 43 °C.
<i>2.8.1.2. Level Source</i>	5	Transducer 1	Take the temperature reading from Transducer 1.

The temperature source can be the temperature sensor built into the transducer or an external TS-3, as set by *2.11.1.4. Temperature Source*.

Loss of Echo (LOE)

Activates an alarm when the HydroRanger 200 HMI loss of echo timer passes without detecting a valid echo.

Parameter	Index	Mode/ Value	Description
<i>2.8.1.2. Level Source</i>	5	Transducer 1	Alarm on LOE for Transducer 1.
<i>2.8.1.4. Relay Function</i>	5	LOE	Alarm on LOE
<i>2.4.2. LOE Timer</i>	Global	0.5	Trip alarm when 0.5 minutes (30 seconds) pass without detecting a valid echo.

Pump control

Setting a Pump Down Group

Example: Sewage wet well

Set a group of three pumps to pump down a wet well.

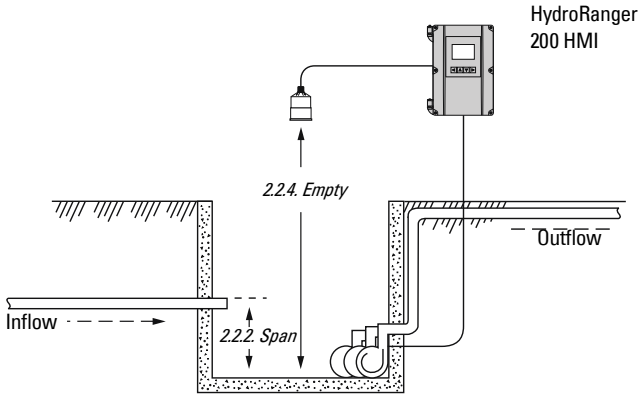

Set the common parameters

Prerequisite: Substitute the details of your application in place of the sample values provided. If you are bench testing the unit, set your test values to be the same as the sample values.

Parameter	Index ¹	Value/ Mode	Description
2.1.3. Sensor Mode	Global	*Level	Operation = *Level
2.1.6. Material	Global	Liquid	Material = *Liquid
2.3.4. Response Rate	Global	Medium	Maximum Process Speed = *Medium (1.0 m/min)
2.1.5. Transducer	Global	XPS-10	Transducer = XPS-10 (single-point preset)
2.1.1. Units	Global	Meters	Units = Meters
2.2.4. Empty	Global	1.8	Empty = 1.8 m
2.2.2. Span	Global	1.4	Span = 1.4 m

¹ Example assumes a single measurement unit. If your HydroRanger 200 HMI has dual-point software installed, then some parameters are indexed by two level points.

Set relays to Alternate Duty Assist

Parameter	Index	Mode	Description
2.8.1.4. Relay Function	1	Alternate Duty Assist	Sets the pump relays
2.8.1.4. Relay Function	2	Alternate Duty Assist	(Relays 1, 2, and 3) to
2.8.1.4. Relay Function	3	Alternate Duty Assist	Alternate Duty Assist.

Set the ON setpoints

Parameter	Index	Value	Description
2.8.1.5. ON Setpoint	1	1.0 m	Sets the three setpoints for the pump
2.8.1.5. ON Setpoint	2	1.1 m	relays. The first cycle will use these
2.8.1.5. ON Setpoint	3	1.2 m	setpoints. Subsequent cycles rotate

Set the OFF setpoints

Parameter	Index	Value	Description
2.8.1.6. OFF Setpoint	1	0.5 m	Sets the three setpoints for the pump
2.8.1.6. OFF Setpoint	2	0.5 m	relays. The first cycle will use these
2.8.1.6. OFF Setpoint	3	0.5 m	setpoints. Subsequent cycles rotate

Setting a Pump Up (Reservoir) Group

Set a group of three pumps to pump up a reservoir.

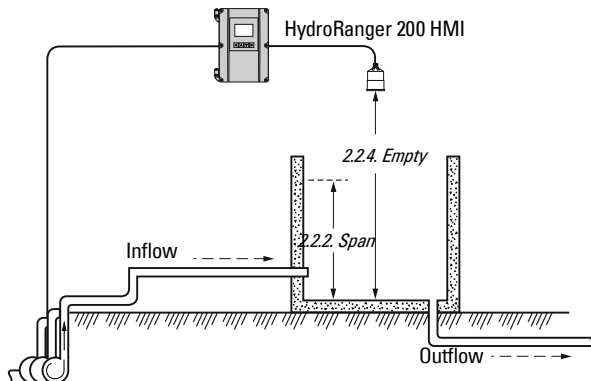

Set the common parameters

Prerequisite: Substitute the details of your application in place of the sample values provided. If you are bench testing the unit, set your test values to be the same as the sample values.

Parameter	Index ¹	Mode/ Value	Description
2.1.3. <i>Sensor Mode</i>	Global	*Level	Operation = *Level
2.1.6. <i>Material</i>	Global	Liquid	Material = Liquid
2.3.4. <i>Response Rate</i>	Global	Medium	Maximum Process Speed = *Medium (1.0 m/min)
2.1.5. <i>Transducer</i>	Global	XPS-10	Transducer = XPS-10 (single-point preset)
2.1.1. <i>Units</i>	Global	-	Units = Meters
2.2.4. <i>Empty</i>	Global	1.8	Empty = 1.8 m
2.2.2. <i>Span</i>	Global	1.4	Span = 1.4 m

- ¹ Example assumes a single measurement unit. If your HydroRanger 200 HMI has dual-point software installed, then some parameters are indexed by two level points.

Set relays to Alternate Duty Assist

Parameter	Index	Mode	Description
2.8.1.4. <i>Relay Function</i>	1	Alternate Duty Assist	Sets the pump relays
2.8.1.4. <i>Relay Function</i>	2	Alternate Duty Assist	(Relays 1, 2, and 3) to
2.8.1.4. <i>Relay Function</i>	3	Alternate Duty Assist	Alternate Duty Assist.

Set the Relay ON Setpoints

Parameter	Index	Value	Description
2.8.1.5. <i>ON Setpoint</i>	1	0.4 m	Sets the three setpoints for the pump
2.8.1.5. <i>ON Setpoint</i>	2	0.3 m	relays. The first cycle will use these
2.8.1.5. <i>ON Setpoint</i>	3	0.2 m	setpoints. Subsequent cycles rotate the setpoints among the pumps.

Set the Relay OFF Setpoints

Parameter	Index	Value	Description
2.8.1.6. <i>OFF Setpoint</i>	1	1.3 m	Sets the three setpoints for the pump
2.8.1.6. <i>OFF Setpoint</i>	2	1.3 m	relays.
2.8.1.6. <i>OFF Setpoint</i>	3	1.3 m	

For more information, see *Appendix B: Pump control reference* on page 241.

Other pump control algorithms

Set relays to Alternate Duty Backup

Parameter	Index	Mode	Description
2.8.1.4. Relay Function	1	Alternate Duty Backup	Sets the pump relays (Relays 1, 2, and 3) to Alternate Duty Backup.
2.8.1.4. Relay Function	2	Alternate Duty Backup	
2.8.1.4. Relay Function	3	Alternate Duty Backup	

Set the Relay ON Setpoints

Parameter	Index	Value	Description
2.8.1.5. ON Setpoint	1	0.4 m	Sets the three setpoints for the pump relays. The first cycle will use these setpoints. Subsequent cycles rotate the setpoints among the pumps.
2.8.1.5. ON Setpoint	2	0.3 m	
2.8.1.5. ON Setpoint	3	0.2 m	

Set the Relay OFF Setpoints

Parameter	Index	Value	Description
2.8.1.6. OFF Setpoint	1	1.3 m	Sets the three setpoints for the pump relays.
2.8.1.6. OFF Setpoint	2	1.3 m	
2.8.1.6. OFF Setpoint	3	1.3 m	

Set relays to Fixed Duty Assist

Parameter	Index	Mode	Description
2.8.1.4. Relay Function	1	Fixed Duty Assist	Sets the pump relays (Relays 1, 2, and 3) to Fixed Duty Assist. Multiple pumps can run simultaneously.
2.8.1.4. Relay Function	2	Fixed Duty Assist	
2.8.1.4. Relay Function	3	Fixed Duty Assist	

Set the Relay ON Setpoints

Parameter	Index	Value	Description
2.8.1.5. ON Setpoint	1	0.4 m	Sets the three setpoints for the pump relays. The setpoints remain attached to the pump relays.
2.8.1.5. ON Setpoint	2	0.3 m	
2.8.1.5. ON Setpoint	3	0.2 m	

Set the Relay OFF Setpoints

Parameter	Index	Value	Description
2.8.1.6. OFF Setpoint	1	1.3 m	Sets the three setpoints for the pump relays.
2.8.1.6. OFF Setpoint	2	1.3 m	
2.8.1.6. OFF Setpoint	3	1.3 m	

Set relays to Fixed Duty Backup

Parameter	Index	Mode	Description
<i>2.8.1.4. Relay Function</i>	1	Fixed Duty Backup	Sets the pump relays (Relays 1, 2, and 3) to Fixed Duty Backup. Only one pump will ever run at one time.
<i>2.8.1.4. Relay Function</i>	2	Fixed Duty Backup	
<i>2.8.1.4. Relay Function</i>	3	Fixed Duty Backup	

Set the Relay ON Setpoints

Parameter	Index	Value	Description
<i>2.8.1.5. ON Setpoint</i>	1	0.4 m	Sets the three setpoints for the pump relays. The setpoints remain attached to the pump relays.
<i>2.8.1.5. ON Setpoint</i>	2	0.3 m	
<i>2.8.1.5. ON Setpoint</i>	3	0.2 m	

Set the Relay OFF Setpoints

Parameter	Index	Value	Description
<i>2.8.1.6. OFF Setpoint</i>	1	1.3 m	Sets the three setpoints for the pump relays.
<i>2.8.1.6. OFF Setpoint</i>	2	1.3 m	
<i>2.8.1.6. OFF Setpoint</i>	3	1.3 m	

Set relays to Service Ratio Duty Assist

Parameter	Index	Mode/Value	Description
<i>2.8.1.4. Relay Function</i>	1	Service Ratio Duty Assist	Sets the pump relays (Relays 1, 2, and 3) to Service Ratio Duty Assist.
<i>2.8.1.4. Relay Function</i>	2	Service Ratio Duty Assist	
<i>2.8.1.4. Relay Function</i>	3	Service Ratio Duty Assist	
<i>2.8.1.12. Service Ratio</i>	1	25	Sets the ratio to: 25% – Pump 1 50% – Pump 2 25% – Pump 3
<i>2.8.1.12. Service Ratio</i>	2	50	
<i>2.8.1.12. Service Ratio</i>	3	25	

Set the Relay ON Setpoints

Parameter	Index	Value	Description
<i>2.8.1.5. ON Setpoint</i>	1	0.4 m	Sets the three setpoints for the pump relays. The first cycle will use these setpoints. Subsequent cycles rotate the setpoints among the pumps.
<i>2.8.1.5. ON Setpoint</i>	2	0.3 m	
<i>2.8.1.5. ON Setpoint</i>	3	0.2 m	

Set the Relay OFF Setpoints

Parameter	Index	Value	Description
<i>2.8.1.6. OFF Setpoint</i>	1	1.3 m	Sets the three setpoints for the pump relays.
<i>2.8.1.6. OFF Setpoint</i>	2	1.3 m	
<i>2.8.1.6. OFF Setpoint</i>	3	1.3 m	

Set relays to First In First Out

Parameter	Index	Mode	Description
<i>2.8.1.4. Relay Function</i>	1	FIFO	Sets the pump relays (Relays 1, 2, and 3) to First In First Out.
<i>2.8.1.4. Relay Function</i>	2	FIFO	
<i>2.8.1.4. Relay Function</i>	3	FIFO	

Set the Relay ON Setpoints

Parameter	Index	Value	Description
<i>2.8.1.5. ON Setpoint</i>	1	0.4 m	Sets the three setpoints for the pump relays. The first cycle will use these setpoints. Subsequent cycles rotate the setpoints among the pumps.
<i>2.8.1.5. ON Setpoint</i>	2	0.3 m	
<i>2.8.1.5. ON Setpoint</i>	3	0.2 m	

Set the Relay OFF Setpoints

Parameter	Index	Value	Description
<i>2.8.1.6. OFF Setpoint</i>	1	1.3 m	Sets the three setpoints for the pump relays.
<i>2.8.1.6. OFF Setpoint</i>	2	1.3 m	
<i>2.8.1.6. OFF Setpoint</i>	3	1.3 m	

Optional pump controls

Starting pumps by rate of level change

Use this function when multiple pumps will be controlled by rate of level change rather than setpoints. Pumping costs can be reduced because only the highest ON setpoint needs to be programmed. This results in a lower difference in head to the next wet well which, in turn, results in less energy being used to pump out the well.

Parameter	Index	Mode/Value	Description
2.8.1.5. ON Setpoint	1	1.35	Starting pumps by rate allows all setpoints to be set higher, to save money by pumping from the highest safe level of the wet well.
2.8.1.5. ON Setpoint	2	1.35	
2.8.1.5. ON Setpoint	3	1.35	
2.8.1.6. OFF Setpoint	1	0.5 m	Notice that all indexed relays for both 2.8.1.5. ON Setpoint and 2.8.1.6. OFF Setpoint are set to the same levels.
2.8.1.6. OFF Setpoint	2	0.5 m	
2.8.1.6. OFF Setpoint	3	0.5 m	
2.8.1.8. Pump by Rate	1	ON	The pumps will start on 20-second intervals until the rate set in 2.3.10. Emptying Indicator is met.
2.8.1.8. Pump by Rate	2	ON	
2.8.1.8. Pump by Rate	3	ON	
2.8.2.8.1. Delay Between Starts	Global	20.0	

When the first ON setpoint is reached, the pumps will start, one by one, until the material level rate of change is set at the same value or greater than the value in:

- 2.8.1.9. Filling Indicator (pump up applications)
- 2.8.1.10. Emptying Indicator (pump down applications)

Set delay between pump starts using 2.8.2.8.1. Delay Between Starts.

Single- and dual-point

- Single-point Mode: One pump by rate control available that affects all pumps.
- Dual-point Mode: A single pump by rate control can be set up for each of the three available level points. Set Operation for difference or average (2.1.3. Sensor Mode = Dual-Point Difference or Dual-Point Average).

Notes:

- Set all pump control relay ON and OFF setpoints to the same value.
- If the level is within 5% of 2.2.2. Span of the OFF setpoint, then the next pump is not started.

Rotating pumps by service ratio

Prerequisite: Set pump relays to a service ratio value (*2.8.1.4. Relay Function* = Service Ratio Duty Assist or Service Ratio Duty Backup).

Parameter	Index	Value	Description
<i>2.8.1.12. Service Ratio</i>	1	1	These values will start Pump 2 fifty percent of the time, and Pumps 1 and 3 each, twenty-five percent of the time.
<i>2.8.1.12. Service Ratio</i>	2	2	
<i>2.8.1.12. Service Ratio</i>	3	1	

Notes:

- The HydroRanger 200 HMI will not sacrifice other pumping strategies to ensure that the ratio is held true.
- If the pump relays are set to the same value, then the ratio equals 1:1 and all pumps are used equally (preset).

When more than one pump is assigned a pump service ratio value (in any time units) and a pump start is required (*2.8.1.5. ON Setpoint*), the pump with the fewest running hours (with respect to the assigned ratio values) starts.

Conversely, when a pump stop is required (*2.8.1.6. OFF Setpoint*), the pump with the most running hours (as compared to the assigned ratio values) stops.

Totalizing pumped volume

Prerequisite: The volume of the vessel must be known.

Parameter	Index	Mode/Value	Description
2.1.3. <i>Sensor Mode</i>	Global	<i>Pump Totalizer</i>	Operation = Pumped volume
2.1.6. <i>Material</i>	Global	*Liquid	These parameters are as shown above.
2.3.4. <i>Response Rate</i>	Global	*Medium (1.0 / min)	
2.1.5. <i>Transducer</i>	Global	XPS-10 (single-point preset)	
2.1.1. <i>Units</i>	Global	Meters	
2.2.4. <i>Empty</i>	Global	1.8	
2.2.2. <i>Span</i>	Global	1.4	
2.7.2. <i>Vessel Shape</i>	Global	Flat Level Bottom	Tank shape is Flat Level Bottom.
2.7.3. <i>Maximum Volume</i>	Global	17.6	Max volume is 17.6m ³ or 17,600 liters.
2.8.1.4. <i>Relay Function</i>	1	Alternate Duty Assist	Sets Relays 1, 2, and 3 as a pump group using Alternate Duty Assist..
2.8.1.4. <i>Relay Function</i>	2	Alternate Duty Assist	
2.8.1.4. <i>Relay Function</i>	3	Alternate Duty Assist	
2.8.1.5. <i>ON Setpoint</i>	1	1.0	Sets the ON setpoints for the pump group.
2.8.1.5. <i>ON Setpoint</i>	2	1.2	
2.8.1.5. <i>ON Setpoint</i>	3	1.4	
2.8.1.6. <i>OFF Setpoint</i>	1	0.2	Sets the OFF setpoints for the pump group.
2.8.1.6. <i>OFF Setpoint</i>	2	0.2	
2.8.1.6. <i>OFF Setpoint</i>	3	0.2	

Set in RUN Mode

1. Press the **LEFT arrow** ◀ to go to Measurement View mode.
2. Once there, press the **DOWN arrow** ▼ to show Measurement View 2.
3. Press the **LEFT arrow** ◀ until Totalizer is shown.

Setting independent fail-safe controls

Independent fail-safe controls allow you to vary an individual relay from the global fail-safe controls programmed in *2.4.5. Material Level*, *2.4.2. LOE Timer*, and *2.4.6. Fail-safe Advance*

Example:

The global fail-safe controls are set to hold, and Relay 5 is set to trigger an alarm bell.

Parameter	Index	Mode/Value	Description
<i>2.4.4. Fail-safe Mode</i>	Global	HOLD	Keep level at last known value.
<i>2.8.2.3. Relay Fail-safe</i>	5	DE-ENERGIZE	De-energize Relay 5, and trigger alarm.

Setting a pump to Run-ON

When you need to pump below the normal OFF setpoint, use *2.8.2.71. Run-ON Interval* and *2.8.2.73. Run-ON Duration* to control this event.

Example:

The pump connected to Relay 3 is set to pump for an extra 60 seconds every 5 hours.

Parameter	Index	Value	Description
<i>2.8.2.71. Run-ON Interval</i>	Global	5	Time in hours of Run-ON interval.
<i>2.8.2.73. Run-ON Duration</i>	3	60	Run-ON for 60 seconds.

Note: *2.8.2.71. Run-ON Interval* counts when the indexed relay is tripped, not the number of pump cycles. If the indexed relay only trips once every four pump cycles, then the actual interval of the run-ON will be 20 pump cycles, or five cycles of Relay 3.

General operation

Setting the pump start delays

The pump start delay ensures that all of the pumps do not start at once to avoid power surges. There are two parameters used: *2.8.2.8.1. Delay Between Starts* and *2.8.2.8.2. Power Resumption Delay*. The default is 10 seconds, but you can increase this if your pumps take longer to spin up.

Example:

The delay between pumps is set to 20 seconds and the delay of the first pump is set to 30 seconds.

Parameter	Index	Value	Description
<i>2.8.2.8.1. Delay Between Starts</i>	Global	20	Wait at least 20 seconds between pump starts.
<i>2.8.2.8.2. Power Resumption Delay</i>	Global	30	Wait for 30 seconds when power is restored.

Reducing wall cling

Use the wall cling parameter to randomly alter the ON and OFF setpoints over a range. This eliminates the ridge of material buildup at the setpoint that can give false echoes.

This setting may increase the number of days between trips to clean the wet well.

Wall cling reduction is set by *2.8.2.6.2. Level Setpoint Variation*. The relay setpoints ON and OFF are randomly varied inside a range so the material level does not stop at the same point.

Example :

A range of 0.5 meters is used to vary the setpoint. The randomly-selected setpoints are always **inside** the ON and OFF setpoints.

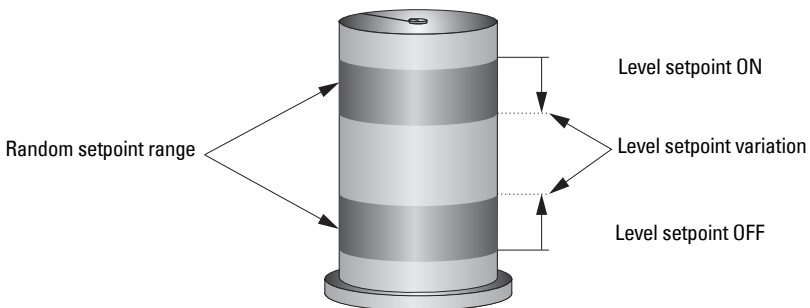

Grouping pumps

You can group pumps and use the same pumping algorithm separately on each group. If you specify different pumping algorithms, then you do not need to use this parameter because the pumps are already grouped by algorithm.

Group pumps only when four pumps are using the same algorithm, and you want to split them into two groups.

Example:

Pumps 1 and 2 will operate as a group, and Pumps 3 and 4 will operate as another group.

Parameter	Index	Mode	Description
2.8.2.2. Pump Group	1	*Group 1	Groups Pumps 1 and 2
2.8.2.2. Pump Group	2	*Group 1	
2.8.2.2. Pump Group	3	Group 2	Groups Pumps 3 and 4
2.8.2.2. Pump Group	4	Group 2	

Setting a flush valve

A flush valve stirs up the sediment at the bottom of the well during pumping, so that it doesn't accumulate. These parameters will control any relays set with 2.8.1.4. *Relay Function* = Flush Valve.

Most sets of parameters will work with only one or two changes; however, for these parameters to work, all of them must be set to a value.

Example:

The flush valve connects to Relay 4 and the watched pump is on Relay 1.

Parameter	Index	Value	Description
2.10.3.1. Relay Selector	-	4	Flush valve is connected to Relay 4.
2.10.3.2. Flush Pump	Global	1	Watch Relay 1 to count pump cycles.
2.10.3.3. Flush Cycles	Global	3	Open the flush valve for 3 cycles.
2.10.3.4. Flush Interval	Global	10	Use the flush value every 10 cycles.
2.10.3.5. Flush Duration	Global	120	Open the flush valve for 120 seconds.

Relay controlled by communications

A relay can be controlled directly by a remote system through communications. No other control schemes can then be used with a relay configured this way. Communications can be used to force status of some control relays, such as pumps.

Settings:

Parameter	Index	Mode	Description
<i>2.8.1.4. Relay Function</i>	5	Communication	Sets Relay 5 to communications control.

Tracking pump usage

You can find out how much an individual pump has been used by viewing the pump records parameters.

Information available	Parameter access
Current RUN time	<i>3.2.7.3. Pump Run Time</i>
Total pump hours	<i>3.2.7.2. Pump Hours</i>
Total pump starts	<i>3.2.7.4. Pump Starts</i>
Total pump RUN on occurrences	<i>3.2.7.5. Pump Run-ONs</i>

Rake (Screen) control

Rakes or screens are mounted on the inflow channel of the wastewater treatment plant to prevent debris from clogging the equipment.

When material builds up on the screen, a level differential is created, and the water level is higher in front of the screen than behind it. When this differential reaches the programmed setpoint, the HydroRanger 200 HMI activates a relay to operate mechanical rakes that clean the screen and ensure a steady flow.

Setting a rake control

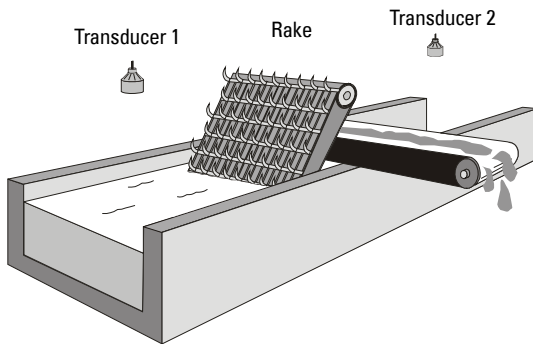

2.2.2. Span
Maximum differential between Point 1 and Point 2 reading also sets 100% scale for bargraph and mA output.

General operation

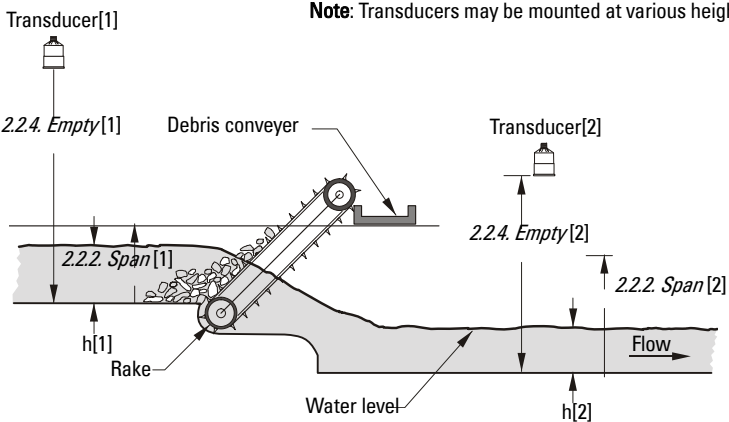

Note: Transducers may be mounted at various heights.

Point 3: Level distance = $h[1] - h[2]$

Setting common parameters

Prerequisite: Substitute the details of your application in place of the sample values provided. If you are bench testing the unit, set your test values to be the same as the sample values.

Parameter	Index	Mode/Value	Description
2.1.3. <i>Sensor Mode</i>	Global	Dual-Point Difference	Operation = Differential
2.1.6. <i>Material</i>	Global	*Liquid	Material = Liquid
2.3.4. <i>Response Rate</i>	1,2	*Medium (1.0 m/min)	Max. Process Speed = Medium
2.1.5. <i>Transducer</i>	1,2	XPS-10 (single-point preset)	Transducer = XPS-10
2.1.1. <i>Units</i>	Global	1	Units = Meters
2.2.4. <i>Empty</i>	1	1.8	Empty = 1.8 m
	2	2.2	Empty = 2.2 m
2.2.2. <i>Span</i>	1	1.4	Span = 1.4 m
	2	1.4	Span = 1.4 m
	3	1.4	Max Differential = 1.4 m

Set Relay 1 (Operate Rake)

Parameter	Index	Mode/Value	Description
2.8.1.2. <i>Level Source</i>	1	Difference or average	Starts the rake when the difference between the two levels rises above 0.4 m and stops the rake when the difference falls below 0.1 m.
2.8.1.4. <i>Relay Function</i>	1	Fixed Duty Assist	
2.8.1.5. <i>ON Setpoint</i>	1	0.4	
2.8.1.6. <i>OFF Setpoint</i>	1	0.1	

Set Relays 2 to 4 (Level Alarms)

Parameter	Index	Mode/Value	Description
2.8.1.2. <i>Level Source</i>	2	Transducer 1	Sets Relay 2 as a high level alarm for Transducer 1, with an ON setpoint of 1.3 m and an OFF setpoint of 1.2 m.
2.8.1.4. <i>Relay Function</i>	2	Level	
2.8.1.5. <i>ON Setpoint</i>	2	1.3	
2.8.1.6. <i>OFF Setpoint</i>	2	1.2	
2.8.1.2. <i>Level Source</i>	3	Transducer 2	Sets Relay 3 as a low level alarm for Transducer 2, with an ON setpoint of 0.2 m and an OFF setpoint of 0.4 m.
2.8.1.4. <i>Relay Function</i>	3	Level	
2.8.1.5. <i>ON Setpoint</i>	3	0.2	
2.8.1.6. <i>OFF Setpoint</i>	3	0.4	
2.8.1.2. <i>Level Source</i>	4	Difference or average	Sets Relay 4 as a rake failure alarm as it uses the differential level point (3), with an ON setpoint of 1.0 and an OFF setpoint of 0.9 m.
2.8.1.4. <i>Relay Function</i>	4	Level	
2.8.1.5. <i>ON Setpoint</i>	4	1.0	
2.8.1.6. <i>OFF Setpoint</i>	4	0.9	

External totalizers and flow samplers

External totalizers are simple counters which count the number of relay clicks produced by the HydroRanger 200 HMI. This is generally used to keep track of Open Channel Monitoring (OCM) or pumped volume totals. Note that both of these values are also stored in the HydroRanger 200 HMI and are available through communications.

Flow samplers are devices which take a sample of liquid when triggered by a relay click. These samples are used to monitor water quality over time. Flow samplers can be driven by OCM volume or by relay click volume settings depending on the application requirements.

Relay contacts

Pumped volume is calculated at the end of the pump cycle. Totalized volume given through a relay set up for totalizer (2.8.1.4. *Relay Function* = Totalizer) will be given in bursts at this time.

Both the open and closed times for the relay contact are provided by 2.10.1.3. *Relay Duration* and are preset to 0.2 seconds. Partial units are added to the next pump cycle.

Example: A relay set up to make one contact for every cubic meter (m^3) of liquid.

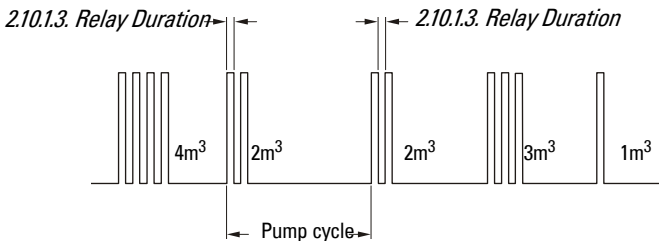

Totalizer

To set the totalizer to provide relay contact to an external counter, use the following:

Counter formula	
1 Contact per $10^{2.10.1.2. Multiplier}$ units	2.10.1.2. <i>Multiplier</i> is preset to 0 so the default number of contacts for a pumped volume cycle is equivalent to the number of volume units.

The source of units depends on the operation:

Operation	Units source parameter
OCM (2.1.3. <i>Sensor Mode</i> = Flow rate in open channel)	2.13.4.3. <i>Maximum Flow</i> or 2.13.4.7. <i>Flowrate Units</i>
Pumped Volume (2.1.3. <i>Sensor Mode</i> = Pump Totalizer)	2.7.3. <i>Maximum Volume</i>

Flow sampler

Based on volume and time

To trigger a flow sampler relay based on flow, use *2.8.1.4. Relay Function=Flow Sampler* and set the other parameters for the selected relay:

Counter formula

1 Contact per *2.10.1.2. Multiplier* x $10^{2.10.2.3. Exponent}$ units

Operation

Units source parameter

OCM (*2.1.3. Sensor Mode=Flow rate* in open channel) *2.13.4.3. Maximum Flow* or *2.13.4.7. Flowrate*
Units

By using a mantissa (*2.10.2.2. Mantissa*) and an exponent (*2.10.2.3. Exponent*), the relay contacts can be based on a volume other than a multiple of ten.

During the periods of low flow, the sampler may be idle for lengths of time. Program *2.8.2.4. Relay Interval Setpoint* to a time interval in hours, to drive the sampler. The sampler will operate based on the volume of flow or the time interval, whichever comes first.

Open Channel Monitoring (OCM)

An OCM installation is defined three ways, with each one based on the Primary Measuring Device (PMD) used:

1. Dimensional (*2.13.2. Primary Measuring Device = Palmer-Bowlus Flume, H-Flume, Rectangular Flume BS-3680, or Thin Plate V-Notch Weir BS-3680*)

For some common weir and flume types. PMD dimensions (*2.13.5. PMD Dimensions*) are entered directly.

- BS-3680 / ISO 1438/1 Thin Plate V-Notch weir on page 103.
- BS-3680 / ISO 4359 Rectangular Flume on page 104.
- Palmer-Bowlus Flume on page 105.
- H-Flume on page 106.

2. Exponential (*2.13.2. Primary Measuring Device = Exponential devices*)

For most other weir and flume types. PMD exponents provided by the manufacturer are entered. Flow is calculated using the exponent (*2.13.4.1. Flow Exponent*) and the maximum values (*2.13.4.2. Maximum Head* and *2.13.4.3. Maximum Flow*).

- Standard weirs on page 107.
- Parshall Flume on page 109.
- Leopold Lagco Flume on page 110.
- Cut Throat Flume on page 111.

3. Universal (*2.13.2. Primary Measuring Device = Universal Linear Flow Calculation, Universal Curved Flow Calculation*)

For all other PMDs, the head-to-flow curve can be plotted based on known breakpoints, usually supplied by the PMD manufacturer.

- Typical flow characterization on page 112.
- Example flumes on page 113.
- Example weirs on page 113.

Common parameters

These parameters are required for all installations.

Parameter	Index	Mode/Value	Description
<i>2.1.3. Sensor Mode</i>	Global	Flow rate in open channel	Operation
<i>2.1.6. Material</i>	Global	Liquid	Material
<i>2.3.4. Response Rate</i>	Global	Medium	Max. Process Speed
<i>2.1.5. Transducer</i>	Global	XPS-10	Transducer
<i>2.1.1. Units</i>	Global	Meters	Units

Parameter	Index	Mode/Value	Description
2.2.4. Empty	Global	1.8	Empty
2.2.2. Span	Global	1.0	Span
2.2.7. Range Extension	Global	0.8	Range Extension to avoid LOE

Setting Zero Head

Many PMDs start flowing higher than the traditional empty distance of the application. You can account for the flow in one of two ways:

1. Use 2.13.4.5. *Zero Head* to have OCM calculations ignore levels below that value.
Possible head = 2.2.2. *Span* minus 2.13.4.5. *Zero Head*.

Note: 2.13.4.2. *Maximum Head* is preset to 2.2.2. *Span*, and is not updated when 2.13.4.5. *Zero Head* is used. Make sure you set 2.13.4.2. *Maximum Head* to the correct value when using 2.13.4.5. *Zero Head*.

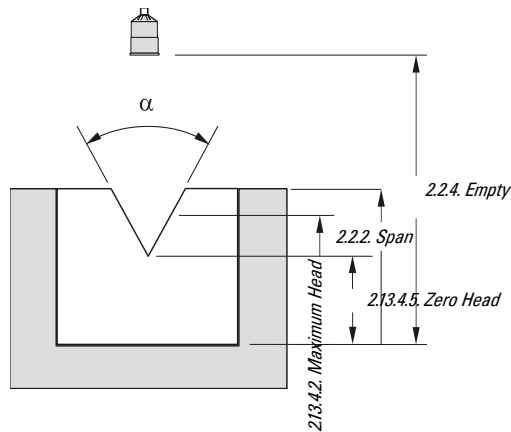

- Use *2.2.7. Range Extension* where the *2.2.4. Empty* level is set to the bottom of the weir, and above the bottom of the channel. It should be used if the surface monitored can fall past the Empty level in normal operation without reporting an LOE. The value in *2.2.7. Range Extension* is added to *2.2.4. Empty* and can be greater than the range of the transducer.

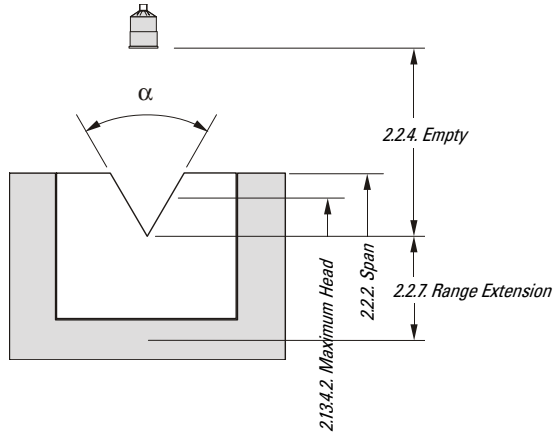

The examples on the following pages show both methods.

Setting totaled volume

The HydroRanger 200 HMI displays the totaled volume in the auxiliary reading area of Measurement View 2 by default.

Applications supported by HydroRanger 200 HMI

BS-3680 / ISO 1438/1 Thin Plate V-Notch weir

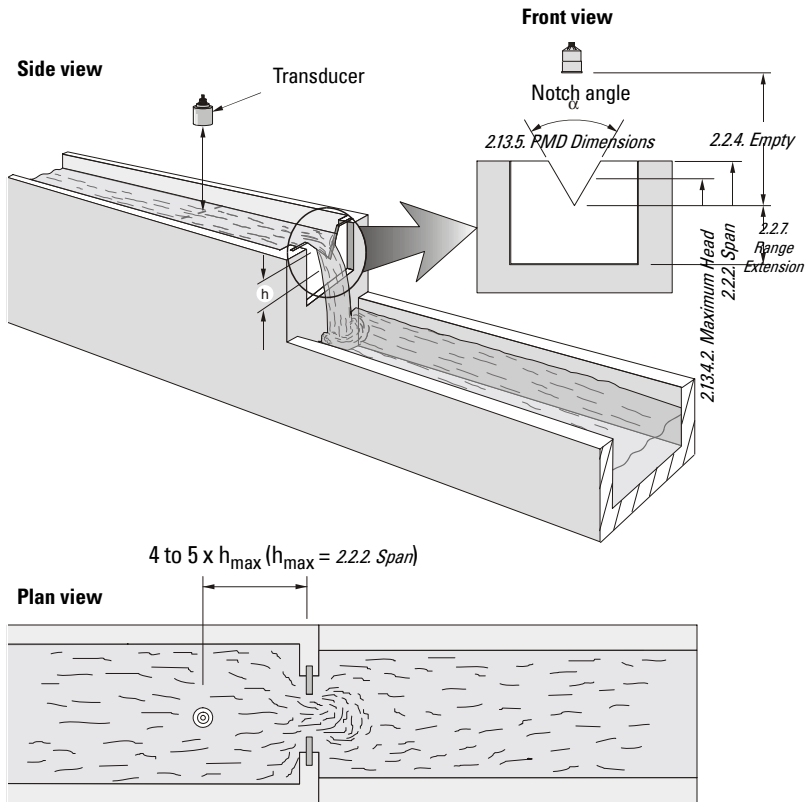

General operation

Parameter	Mode
<i>2.13.2. Primary Measuring Device</i>	ISO 1438/1 Thin Plate V-Notch Weir BS-3680
<i>2.13.5. PMD Dimensions</i>	
<i>2.13.5.1. OCM Dimension 1</i>	Notch angle
<i>2.13.5.2. OCM Dimension 2 (Read only)</i>	Discharge coefficient (Cd)
<i>2.13.4.2. Maximum Head</i>	Maximum Head
<i>2.2.7. Range Extension</i>	Range Extension
<i>2.13.4.7. Flowrate Units</i>	Flowrate Units

BS-3680 / ISO 4359 Rectangular Flume

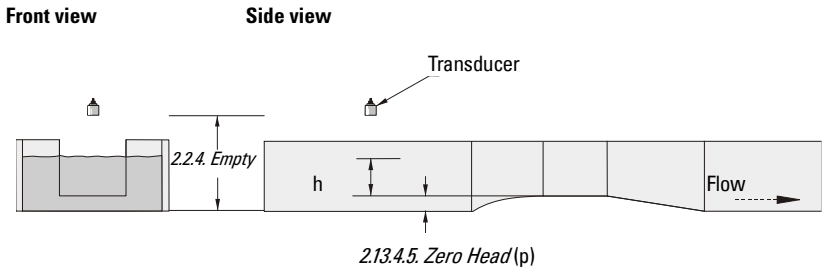
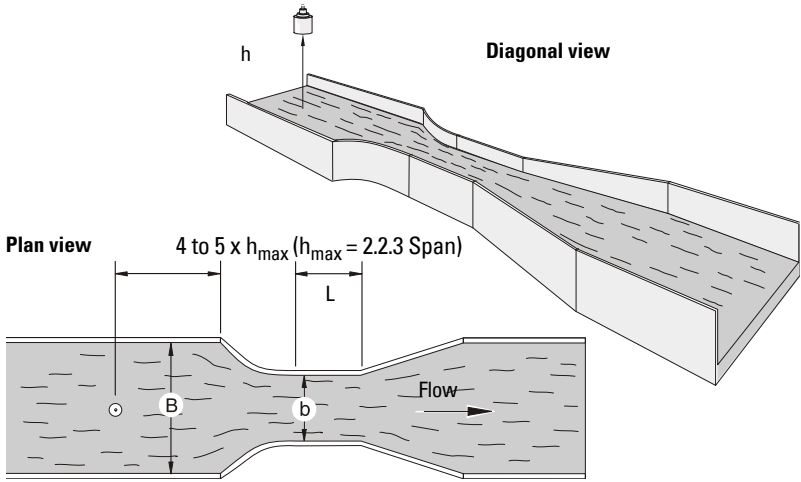

Parameter	Mode
2.13.2. Primary Measuring Device	ISO 4359 Rectangular Flume BS-3680
2.13.5. PMD Dimensions	
2.13.5.1. OCM Dimension 1	Approach width (B)
2.13.5.2. OCM Dimension 2	Throat width (b)
2.13.5.3. OCM Dimension 3	Hump height (p)
2.13.5.4. OCM Dimension 4	Throat length (L)
2.13.5.5. OCM Dimension 5 (Read only)	Velocity coefficient (Cv)
2.13.5.6. OCM Dimension 6 (Read only)	Discharge coefficient (Cd)
2.13.4.5. Zero Head	Zero Head
2.13.4.7. Flowrate Units	Flowrate Units

Palmer-Bowlus Flume

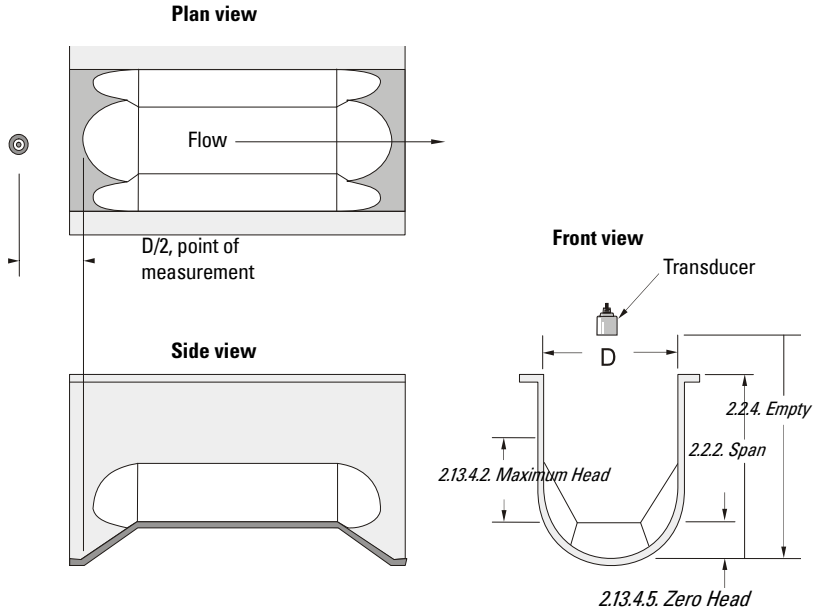

Parameter	Mode
2.13.2. Primary Measuring Device	Palmer-Bowlus
2.13.5. PMD Dimensions	
2.13.5.1. OCM Dimension 1	Flume width (D)
2.13.4.2. Maximum Head	Maximum Head
2.13.4.3. Maximum Flow	Maximum Flow
2.13.4.5. Zero Head	Zero Head
2.13.4.4. Flow Time Units	Time Units

Application information

- Sized by pipe diameter D.
- Flume relief is trapezoidal.
- Designed to install directly into pipelines and manholes.
- Head is referenced to bottom of the throat, not bottom of the pipe.
- For rated flows under free flow conditions, the head is measured at a distance of $D/2$ upstream from the beginning of the converging section.

General operation

H-Flume

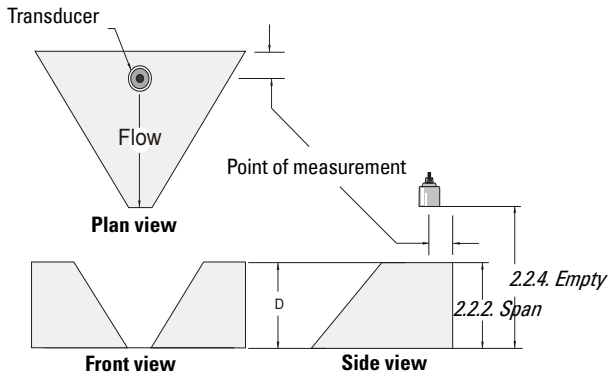

Parameter	Mode
2.13.2. Primary Measuring Device	H-Flume
2.13.5. PMD Dimensions	
2.13.5.1. OCM Dimension 1	Flume height (D)
2.13.4.2. Maximum Head	Maximum Head
2.13.4.3. Maximum Flow	Maximum Flow
2.13.4.4. Flow Time Units	Time Units

- Sized by maximum depth of flume.
- Approach is preferably rectangular, matching width and depth for distance, 3 to 5 times the depth of the flume.
- May be installed in channels under partial submergence (ratio of downstream level to head). Typical errors are:
 - 1% @ 30% submergence
 - 3% @ 50% submergence
- For rated flows under free flow conditions, the head is measured at a point downstream from the flume entrance.

Flume size (Diameter in feet)	Point of measurement	
	Centimeters	Inches
0.5	5	1¼
0.75	7	2¾
1.0	9	3¾
1.5	14	5½
2.0	18	7¼
2.5	23	9
3.0	28	10¾
4.5	41	16¾

- H-Flumes come with a flat or sloping floor. The same flow table can be used because error is less than 1%.

General operation

PMDs with exponential flow to Head Function

For Primary Measuring Devices (PMDs) that measure flow by an exponential equation, use these parameters. Ensure that you use the correct exponent for your PMD; the values below are samples only.

Standard weirs

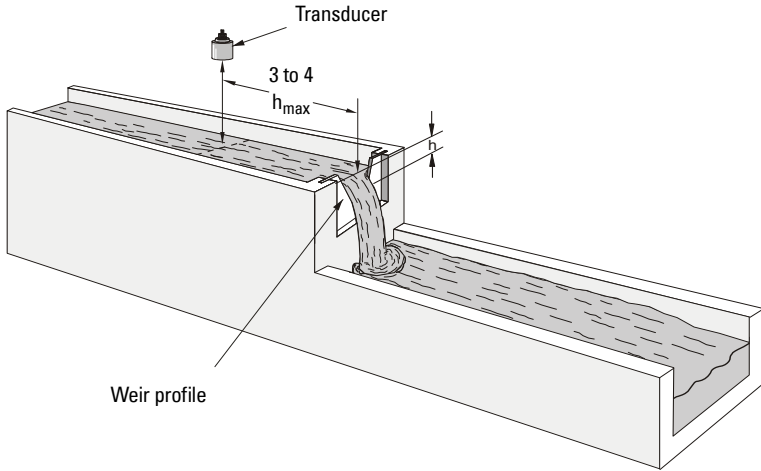

Applicable weir profiles

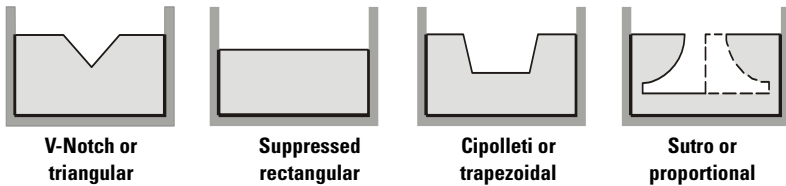

Parameter	Index	Mode										
2.13.2. Primary Measuring Device	Global	Exponential devices										
2.13.4.1. Flow Exponent	Global	<table border="1"> <thead> <tr> <th>Weir type</th> <th>Value¹</th> </tr> </thead> <tbody> <tr> <td>V-Notch Weir</td> <td>2.50</td> </tr> <tr> <td>Suppressed Rectangular Weir</td> <td>1.50</td> </tr> <tr> <td>Cipolletti Weir or trapezoidal</td> <td>1.00</td> </tr> <tr> <td>Sutro or proportional</td> <td></td> </tr> </tbody> </table>	Weir type	Value ¹	V-Notch Weir	2.50	Suppressed Rectangular Weir	1.50	Cipolletti Weir or trapezoidal	1.00	Sutro or proportional	
Weir type	Value ¹											
V-Notch Weir	2.50											
Suppressed Rectangular Weir	1.50											
Cipolletti Weir or trapezoidal	1.00											
Sutro or proportional												
2.13.4.2. Maximum Head	Global	Maximum Head										
2.13.4.3. Maximum Flow	Global	Maximum Flow										
2.13.4.4. Flow Time Units	Global	Time Units										
2.2.7. Range Extension	Global	Range Extension										

¹. Values are samples only. Consult weir manufacturer's documentation for correct flow exponent.

Non-applicable weir profiles

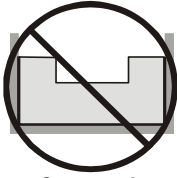

**Contracted
rectangular**

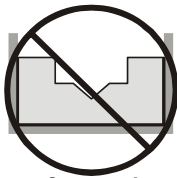

Compound

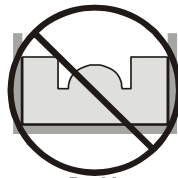

Poebing

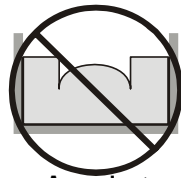

**Approximate
exponential**

Flows through these weirs can be measured using *2.13.2. Primary Measuring Device* set to Universal Linear Flow Calculation or Universal Curved Flow Calculation. See *Universal calculation support* on page 112.

Parshall Flume

Note: C = Converging dimension.

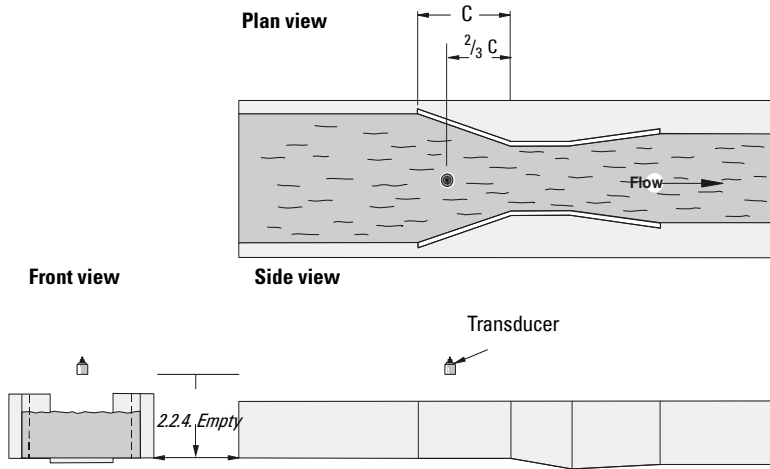

Application information

- Sized by throat width.
- Set on solid foundation.
- For rated flows under free flow conditions, the head is measured at $\frac{2}{3}$ the length of the converging section from the beginning of the throat section.

Parameter	Index	Mode
2.13.2. Primary Measuring Device	Global	Parshall Flume
2.13.4.1. Flow Exponent	Global	1.22–1.607 (consult your flume documentation)
2.13.4.2. Maximum Head	Global	Maximum Head
2.13.4.3. Maximum Flow	Global	Maximum Flow (Q)
2.13.4.4. Flow Time Units	Global	Time Units

Leopold Lagco Flume

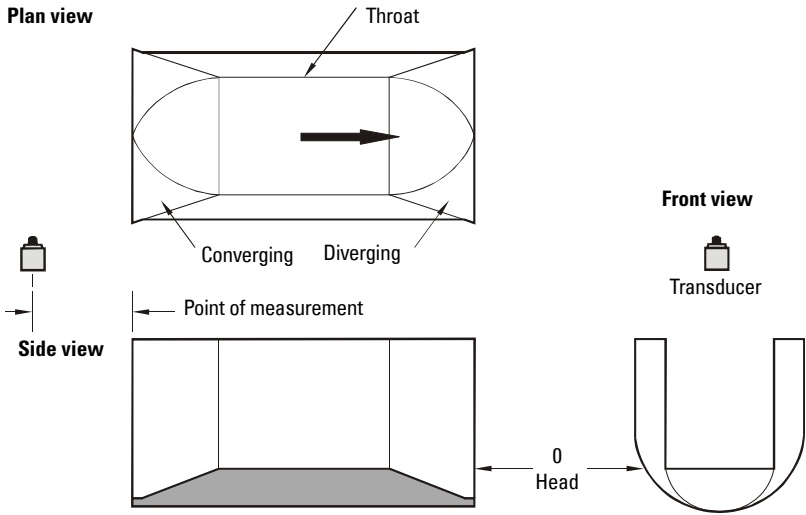

Parameter	Index	Mode
2.13.2. Primary Measuring Device	Global	Leopold Lagco
2.13.4.1. Flow Exponent	Global	1.55
2.13.4.2. Maximum Head	Global	Maximum Head
2.13.4.3. Maximum Flow	Global	Maximum Flow
2.13.4.5. Zero Head	Global	Zero Head
2.13.4.4. Flow Time Units	Global	Time Units

Application information

- Designed to be installed directly into pipelines and manholes.
- Leopold Lagco may be classed as a rectangular Palmer-Bowlus flume.
- Sized by pipe (sewer) diameter.
- For rated flows under free flow conditions, the head is measured at a point upstream referenced to the beginning of the converging section.

Flume size (Pipe diameter in inches)	Point of measurement	
	Centimeters	Inches
4-12	2.5	1
15	3.2	1¼
18	4.4	1¾
21	5.1	2
24	6.4	2½
30	7.6	3
42	8.9	3½
48	10.2	4
54	11.4	4½
60	12.7	5
66	14.0	5½
72	15.2	6

Cut Throat Flume

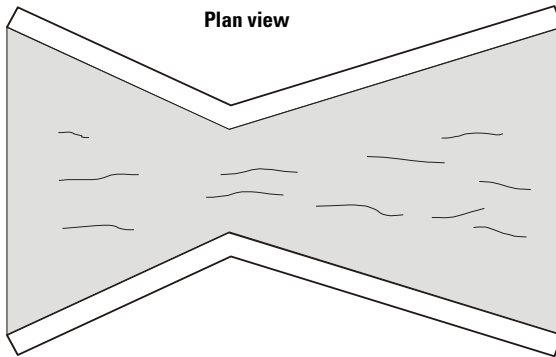

Application information

- Similar to Parshall Flume, except that the floor is flat bottomed and throat has no virtual length.
- Refer to manufacturer's specifications for flow equation and point of head measurement.

Parameter	Index	Mode/Value
2.13.2. Primary Measuring Device	Global	Cut Throat Flume
2.13.4.1. Flow Exponent	Global	1.55
2.13.4.2. Maximum Head	Global	Maximum Head
2.13.4.3. Maximum Flow	Global	Maximum Flow
2.13.4.4. Flow Time Units	Global	Time Units

Universal calculation support

When the Primary Measuring Device (PMD) doesn't fit one of the standard types, it can be programmed using a universal characterization. When *2.13.2. Primary Measuring Device = Universal*, then the head/flow breakpoints must be entered into *2.13.6. Universal Head vs. Flow*.

Two curve types are supported:

- Universal Linear Flow Calculation (piece wise linear)
- Universal Curved Flow Calculation (cubic spline)

Both are shown in the following chart.

Typical flow characterization

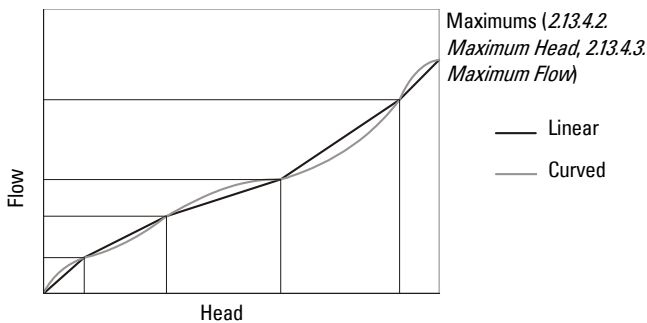

Characterization is achieved by entering *2.13.6.1.1. Head 1* and its corresponding *2.13.6.1.2. Flow 1* (see page 180 for details), either from empirical measurement or from the manufacturer's specification. Increasing the number of defined breakpoints will increase the accuracy of the flow measurement.

Breakpoints should be concentrated in areas exhibiting the higher degrees of nonlinear flow. A maximum of 32 breakpoints can be defined. The curve's end point is always specified by the parameters *2.13.4.2. Maximum Head* and *2.13.4.3. Maximum Flow* for a maximum total of 33 breakpoints.

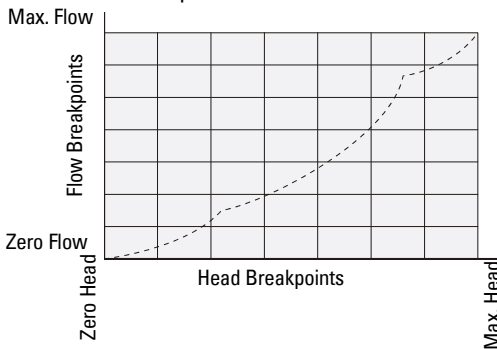

Use as many breakpoints as required by the complexity of your PMD.

See *Volume* on page 76 for additional information.

Example flumes

These example flumes would both require a universal calculation.

Trapezoidal

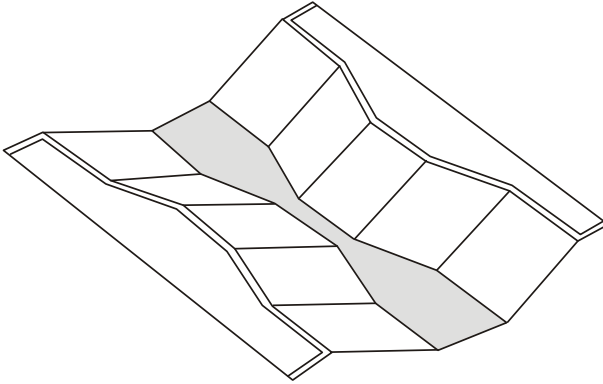

Dual Range (nested) Parshall

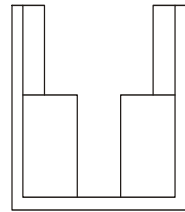
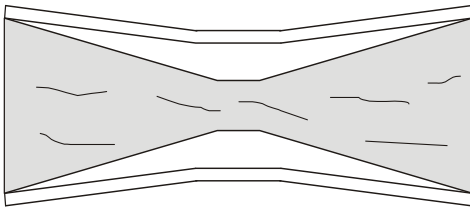

General operation

Example weirs

These weirs could require universal calculation.

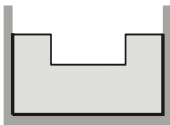

Contracted rectangular

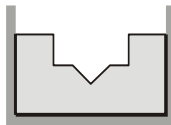

Compound

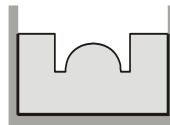

Poebing

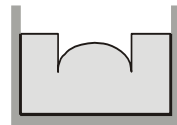

Approximate exponential

Configuration testing

After programming the unit, you must test the device to ensure that it performs to your specifications. This test can be run by varying the level in the application.

I/O Checkout

After the unit is installed, test to verify the wiring.

Relays

Use *3.2.5. Relay Logic Test* to force a state change and verify that the results are as expected (pump starts, alarm sounds, etc.).

Discrete inputs

Use *2.9.2.1. Discrete Input 1* or *2.9.2.2. Discrete Input 2* to force the input and verify that the results are as expected.

1. Go to [DI] where DI = the discrete input to be tested.
2. Set to **OFF**.
3. Go to *2.9.2.3. Discrete Input 1 Scaled State* [DI] to verify that the value is forced.
4. Check the state of outputs to ensure that they respond as expected.
5. Go to [DI].
6. Set to **Forced ON**.
7. Go to *2.9.2.3. Discrete Input 1 Scaled State* [DI] to verify that the value is forced.
8. Check the state of outputs to ensure that they respond as expected.

For further information see *Discrete inputs* on page 68.

mA Input

Use *2.6.5. Scaled mA Input Value* to test the mA input value against a true level. Use a trusted external mA source to generate the signal required for testing, and verify the incoming signal with *2.6.6. Raw mA Input Value*. Check that the system responds as expected when the mA level is changed.

mA Output

Use an external device to test the mA output against the measured level. Check that the mA value changes to reflect the changes in the measured level.

Application test

If you are testing the application by varying the material level, make sure that none of the control devices are connected (or that at least no power is available to them).

While the level is being cycled, check the results of the discrete inputs either by closing the circuit externally (preferred) or by using *2.9.2.1. Discrete Input 1* or *2.9.2.2. Discrete Input 2* to force the input ON or OFF. Try all possible combinations to thoroughly test the

setup. For each combination, run a complete cycle to verify that the relays operate as expected.

Monitor system performance carefully, under all anticipated operating conditions.

1. When the HydroRanger 200 HMI performs exactly as required, programming is complete.
2. If alternate reading units, fail-safe action, or relay operation is desired, update the parameters for the new functionality.
3. If the system performance experiences problems, see *Troubleshooting* on page 212.

Retest the system every time you adjust any control parameters.

Parameters

The HydroRanger is configured through its parameters, and the application determines the parameter values which are entered into the unit.

Please check your value entries carefully before operating the HydroRanger to ensure optimum performance.

Key terms

In the following parameter tables, please note these key terms:

- **Default** - the factory-set value or option; indicated with an **asterisk (*)** or specified as a **preset value**.
- **Global** - pertains to values that are common for all inputs and outputs on the unit.
- **Index** - when parameters apply to more than one input, they are indexed. The index selector value defines the input/output for that parameter. For example, index relates to transducer inputs or mA outputs, and can also refer to relays, communications ports, and other parameters.

Notes:

- Parameter range values are displayed in the default of the defined unit of measure. For example, if a parameter description states that it is *defined in Units*, the range for that parameter will be shown in meters [as meters (m) is the default for Units].
- The number of decimals displayed for a parameter value will depend on the unit of measure, unless decimal places can be set by the user (such as, Totalizers - 2.14.4. *Totalizer Decimal Position*).
- To enter Program mode using the local push buttons, press ►. Press ◀ to return to Measurement mode.

Parameter indexing

When certain parameters apply to more than one input or output, an **index selector parameter** is used. The index selector parameter defines the measurement signal path for each input or output of its applicable parameter.

The **Level Selector** is the most commonly used index selector parameter; it is required for almost all inputs and outputs. In the illustration below, *2.1.2. Level Selector* assigns the Point (Level 1, 2 or 3) to the succeeding options to be made, such as transducer number (*2.1.4. Transducer Selector* on page 123) and transducer type (*2.1.5. Transducer* on page 124).

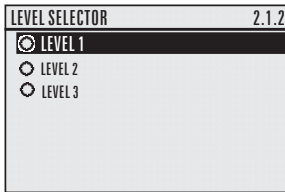

The block diagram below traces an example signal path where an input is scaled and converted into an output, using various index selector parameters (*2.1.4. Transducer Selector*, *2.1.2. Level Selector*, *2.5.1. mA Output Selector*, and *2.8.1.1. Relay Selector*).

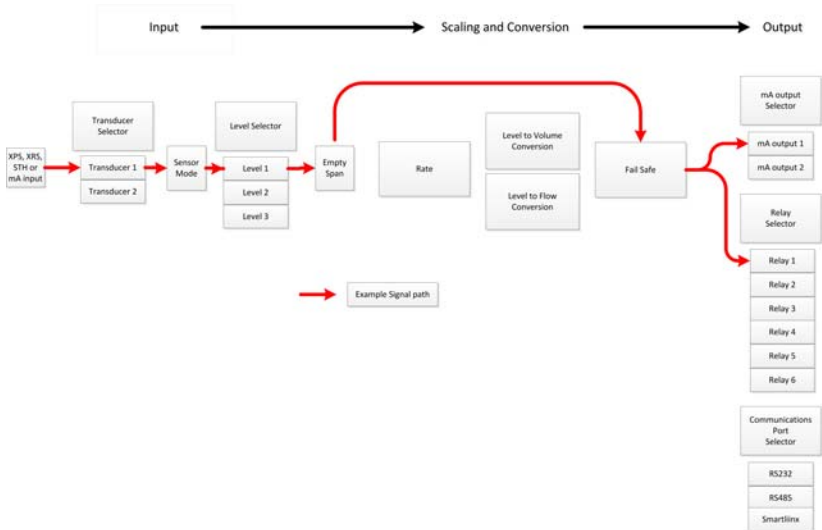

Notes

- Setting up the HydroRanger 200 HMI may be done through the index selector parameters; however, using the Quick Start Wizards is still the preferred method to commission the device.
- An indexed transducer is commonly referred to as a Point (short for Level Point). A Point number refers to indexed transducers.
- Indexes are set in each sub-menu by one or more selector parameters.
- Transducers are always indexed when the dual-point option is enabled.
- On a single-point HydroRanger 200 HMI, transducer parameters are indexed only if Operation (*2.1.3. Sensor Mode*) is set to Difference (mode = Dual-Point Difference) or Average (mode = Dual-Point Average).
- Index selector parameters contain a value for each selector regardless if that selector is used or not.
- To view or change a parameter that applies to a different index in the same sub-menu, the new index must be first set in the selector parameter.
- For optimum performance, set selector values accurately for indexed parameters. Ensure that the correct index value is being changed for each parameter value.
- If the device is a single point unit, some selector parameters will not be visible unless Differential or Average operation is selected.

Index selector examples

The examples provided below show the behavior of the index selector parameters for an application requiring **Level** measurement and relays to control a small level in small vessels with pumps and high alarm. See *Parameters* on page 117 for more details.

Sensor and measurement

1. Navigate to *2.1. Sensor*.
2. Set *2.1.1. Units* to meters.
3. Set *2.1.4. Transducer Selector* to Transducer 1 for the first vessel.
4. Set *2.1.3. Sensor Mode* to *Level.
5. Set *2.1.5. Transducer* to XPS-10.

Note: Repeat this procedure if a second ultrasonic sensor or mA is needed. Choose Transducer 2 in *2.1.4. Transducer Selector*.

Calibration

1. Navigate to *2.2. Calibration*.
2. Set *2.2. Calibration* to Transducer 1 for the first vessel.
3. Set *2.2.4. Empty* to 2.5 meters.
4. Set *2.2.2. Span* to 2 meters.

Notes:

- Repeat this procedure for the second ultrasonic sensor or when mA input has been configured.
- Choose Transducer 2 in *2.2. Calibration*.
- If the HydroRanger 200 HMI is a dual-point model, Transducer 3 will be available in *2.2. Calibration* for Differential or Average calculations between the Transducer 1 and Transducer 2 measurements.

Pumps

1. Navigate to *2.8.1. Basic Setup*.
2. Set *2.8.1.1. Relay Selector* to Relay 1 to program the first pump.
3. Set *2.8.1.2. Level Source* to Transducer 1. Relay 1 will activate or de-activate based on the values of this measurement.
4. Set *2.8.1.4. Relay Function* to Alternate Duty Assist.
5. Set *2.8.1.5. ON Setpoint* to 1.25 meters.
6. Set *2.8.1.6. OFF Setpoint* to 0.25 meters.
7. Navigate back to *2.8.1.1. Relay Selector* and select Relay 2 to program the second pump, using new setpoint values.
8. If the relay is controlled by the second transducer measurement, set *2.8.1.2. Level Source* to Transducer 2.
9. Repeat this procedure for each required relay. Ensure that the correct relay index is selected in *2.8.1.1. Relay Selector*.

High level alarm

1. Navigate to *2.8.1. Basic Setup*.
2. Set *2.8.1.1. Relay Selector* to Relay 1 to program the high level alarm.
3. Set *2.8.1.2. Level Source* to Transducer 1.
4. Set *2.8.1.4. Relay Function* to *Level*.
5. Set *2.8.1.5. ON Setpoint* to 2 meters.
6. Set *2.8.1.6. OFF Setpoint* to 1.75 meters.
7. Repeat this procedure for each required relay. Ensure that the correct relay index is selected in *2.8.1.1. Relay Selector*.

Index types

Indexes are set in each sub-menu by one or more selector parameters. To view or change a parameter that applies to a different index, the new index must be set in the selector parameter first.

Name	Description	# of indexes
Global	This parameter applies to the entire device.	n/a
Read only	This parameter cannot be set, only viewed.	n/a
Discrete Input	Indexed by discrete input	2
Echo Profile	Indexed by stored echo profile	10
Level ¹	Indexed by level point	1, 2 or 3
mA input ¹	Indexed by mA input	1
mA output ¹	Indexed by mA output	0 or 2
Comm. Port	Indexed by communications port	2
Relay	Indexed by relay	6
Transducer ²	Indexed by transducer	1 or 2

¹. The three Level points are: Transducer 1, Transducer 2, and the calculated point which can be difference (*2.1.3. Sensor Mode= Dual-Point Difference*) or average (*2.1.3. Sensor Mode= Dual-Point Average*). Level point typically has 1 index in Single-point Mode (standard), and 2 indexes in Dual-Point Mode (optional). A third index is available in both modes when Operation (*2.1.3. Sensor Mode*) is set for DPD (*2.1.3. Sensor Mode= Dual-Point Difference*) or DPA (*2.1.3. Sensor Mode= Dual-Point Average*).

². The number of indexes available in Single-point Mode (standard) is typically 1, but can be expanded to 2 if *2.1.3. Sensor Mode* is set for DPD (*2.1.3. Sensor Mode= Dual-Point Difference*) or DPA (*2.1.3. Sensor Mode= Dual-Point Average*).

In Dual-Point Mode (optional), the number of available indexes is always 2.

1. Quick Start Wizards

Wizards group together all the settings needed for a particular feature, for easy configuration. The HydroRanger 200 HMI offers several Wizards. All can be accessed via the local push buttons.

For more details on the Wizards listed below, see *Quick Start Wizards* on page 31.

1.1. Quick Start

1.1.1. QS Level

1.1.2. QS Volume

1.1.3. QS Flow

1.2. Pump Control

2. Setup

2.1. Sensor

2.1.1. Units

Determines sensor measurement units used when 2.1.3. Sensor Mode is set to Level, Space, Distance, or Head.

Options	*M (meters)
	CM (centimeters)
	MM (millimeters)
	FT (feet)
	IN (inches)

2.1.2. Level Selector

Sets the Level Point index for all parameters applicable to this sub-menu.

Options	*Level 1
	Level 2
	Level 3

2.1.3. Sensor Mode

Sets the type of measurement required for the application.

Index	Single-point model	Dual-point model
	Global	Transducer
Options (Mode)	Out of service	
	*Level	(how full the vessel is; default for dual-point model)
	Space	(how empty the vessel is)
	*Distance	(distance from transducer to material; default for single-point model)
	Dual-Point Difference	(DPD)
	Dual-Point Average	(DPA)
	Flow rate in open channel	(OCM)
	Pump Totalizer	(total pumped volume)
Alters	2.13.2. Primary Measuring Device	

Dual-Point Difference (DPD) and Dual-Point Average (DPA)

Single-point model use

For DPD or DPA, the unit requires either two transducers of the same type, or one transducer and one mA input. If two transducers are used, all transducer parameters become indexed, and a third level point is calculated.

- DPD (difference) = Point 1 - Point 2
- DPA (average) = (Point 1 + Point 2)/2. The calculated DPD or DPA is always based on level measurements of Points 1 and 2.

For these operations any of three level points (Transducer 1, Transducer 2, or the calculated point) can be used to trigger relays (2.8.1.2. *Level Source* on page 146).

The points must be globally set to either Dual-Point Difference or Dual-Point Average, as required. Point 3 becomes the calculated value as shown above. See *Setting a rake control* on page 91 for more information.

Dual-point model use

To set a dual-point HydroRanger for DPD or DPA functions, Point 3 must be set to either Dual-Point Difference or Dual-Point Average, as required. Points 1 and 2 cannot be set to Dual-Point Difference or Dual-Point Average, but these points are used to calculate the value in Point 3.

This table shows the available functions:

Operation	Index	Available options
2.1.3. Sensor Mode	1	*Level, Space, *Distance, Flow rate in open channel, Pump Totalizer
	2	*Level, Space, *Distance, Flow rate in open channel, Pump Totalizer
	3	Dual-Point Difference, Dual-Point Average

2.1.4. Transducer Selector

Sets the transducer index for all parameters applicable to this sub-menu. All parameter values will then apply to the selected index.

To view or set a parameter for a different index, select it in this parameter.

Options	*Transducer 1
	Transducer 2

Example: If Transducer 1 is selected, the 2.2.4. *Empty* and 2.2.2. *Span* values viewed in that particular parameter apply only to Transducer 1. Any change to the values will be applied to Transducer 1.

Note: To set or read 2.2.4. *Empty* and 2.2.2. *Span* for Transducer 2, the selector parameter must first be changed to Transducer 2.

2.1.5. Transducer

Specifies the model of the Siemens transducer connected to the device.

Index	Single-point model	Dual-point model
		Global
Options	*No transducer (dual-point preset)	
	ST-25	
	ST-50	
	STH	
	XCT-8	
	*XPS-10 (single-point preset)	
	XCT-12	
	XPS-15	
	XRS-5	
	mA input	
Related	<ul style="list-style-type: none"> • 2.6. <i>Current Input</i> • 2.2.6. <i>Blanking</i> • 2.11.2.5. <i>Reform Echo</i> • 2.11.4. <i>TVT Shaper</i> • 2.1.11. <i>Number of Short Shots</i> • 2.1.12. <i>Number of Long Shots</i> • 2.1.7. <i>Short Shot Frequency</i> • 2.1.8. <i>Long Shot Frequency</i> • 2.1.10. <i>Long Shot Duration</i> • 2.1.9. <i>Short Shot Duration</i> • 2.11.2.12. <i>Short Shot Range</i> 	

2.1.6. Material

Specifies material type.

Index	Single-point model	Dual-point model
		Global
Options	*Liquid	
	Solid	
Alters	2.11.3.6. <i>TVT Type</i>	

2.1.7. Short Shot Frequency

Adjusts the short shot transmit pulse frequency, in kHz.

Index	Single-point model	Dual-point model
	Global	Transducer
Values	Range: 41 to 46 kHz, nearest acceptable value is returned	
Altered by	2.1.5. Transducer	
Related	<ul style="list-style-type: none">• 2.1.11. Number of Short Shots• 2.1.10. Long Shot Duration• 2.1.1.2.10. Short Shot Bias• 2.1.1.2.11. Short Shot Floor• 2.1.1.2.12. Short Shot Range	

2.1.8. Long Shot Frequency

Adjusts the long shot transmit pulse frequency, in kHz.

Index	Single-point model	Dual-point model
	Global	Transducer
Values	Range: 41 to 46 kHz, nearest acceptable value is returned	
Altered by	2.1.5. Transducer	
Related	<ul style="list-style-type: none">• 2.1.12. Number of Long Shots• 2.1.7. Short Shot Frequency• 2.1.8. Long Shot Frequency• 2.1.9. Short Shot Duration	

2.1.9. Short Shot Duration

Adjusts the duration of the short shot transmit pulse, in milliseconds.

Index	Single-point model	Dual-point model
	Global	Transducer
Values	Range: 0.000 to 5.000	
Altered by	2.1.5. Transducer	
Related	<ul style="list-style-type: none">• 2.1.12. Number of Long Shots• 2.1.10. Long Shot Duration• 2.1.8. Long Shot Frequency	

2.1.10. Long Shot Duration

Adjusts the duration of the long shot transmit pulse, in milliseconds.

Index	Single-point model	Dual-point model
	Global	Transducer
Values	Range: 0.000 to 5.000	
Altered by	2.1.5. Transducer	
Related	<ul style="list-style-type: none">• 2.1.11. Number of Short Shots• 2.1.7. Short Shot Frequency• 2.1.9. Short Shot Duration• 2.1.1.2.10. Short Shot Bias• 2.1.1.2.11. Short Shot Floor• 2.1.1.2.12. Short Shot Range	

2.1.11. Number of Short Shots

Sets the number of short shots to be fired (and results averaged) per transmit pulse.

Index	Single-point model	Dual-point model
	Global	Transducer
Values	Range: 0 to 100	
	Preset: 1	
Related	<ul style="list-style-type: none">• 2.1.12. Number of Long Shots• 2.1.7. Short Shot Frequency• 2.1.10. Long Shot Duration• 2.1.2.10. Short Shot Bias• 2.1.2.11. Short Shot Floor• 2.1.2.12. Short Shot Range	

2.1.12. Number of Long Shots

Sets the number of long shots to be fired (and results averaged) per transmit pulse.

Index	Single-point model	Dual-point model
	Global	Transducer
Values	Range: 0 to 200	
	Preset: 5	
Altered by	2.3.4. Response Rate	
Related	<ul style="list-style-type: none">• 2.1.11. Number of Short Shots• 2.1.8. Long Shot Frequency• 2.1.9. Short Shot Duration	

This value is automatically altered by 2.3.4. Response Rate.

2.1.13. Shot Synchro

Enables the System Sync on the terminal block.

Index	Global
Options	Not required
	*Synchronize level monitors

Use this if another level measurement system is mounted nearby, and wired together on the Sync terminal.

2.1.14. Scan Delay

Adjusts the delay between measurements from transducer points, in seconds. Dual-point model only.

Index	Global
Values	Range: 0 to 60 seconds
	Preset: 5
Altered by	2.3.4. Response Rate
Related	2.1.3. Sensor Mode

This feature may only be used to adjust the delay before the next point is scanned. This value is automatically altered when 2.3.4. Response Rate is altered.

2.1.15. Scan Time

Shows the elapsed time, in seconds, since the point displayed was last scanned.

Index	Level
Values	Range: 0.000 to 9999 (Read only)
Related	2.1.3. Sensor Mode

This may be viewed as an Auxiliary Reading in the RUN mode.

2.1.16. Shot Delay

Adjusts the delay (in seconds) between transducer shots.

Index	Transducer
Values	Range: 0.1 to 4.0
	Preset: 0.5

Use this if transient acoustic noise within the vessel is causing measurement difficulties due to echoes from one shot being received on the next. If more than one ultrasonic unit is installed for redundancy, this value should be **0**.

2.1.17. Shot/pulse Mode

Determines what type of ultrasonic shots are fired.

Index	Single-point model	Dual-point model
		Global
Options	Short	
	*Short and long	
Related	<ul style="list-style-type: none">• 2.2.4. Empty• 3.2.9.2. Long Confidence• 2.11.2.3. Long Echo Threshold• 2.11.2.12. Short Shot Range	

Increases HydroRanger response when the monitored surface is close to the transducer face. Select **Short and long** to have short and long acoustic shots fired for each measurement, regardless of the transducer to surface distance. Select **Short** to have only short shots fired if the 3.2.9.2. Long Confidence produced by a short shot exceeds the short 2.11.2.3. Long Echo Threshold and the monitored surface is always within the 2.11.2.12. Short Shot Range.

2.2. Calibration

2.2.1. Level Selector

Sets the Level Point index for all parameters applicable to this sub-menu.

2.2.2. Span

Sets the range to be measured.

Index	Level
Values	Range: 0.000 to 99.000 m (or equivalent, depending on 2.1.1. Units)
	Preset: based on 2.2.4. Empty

Alters	<ul style="list-style-type: none"> • 2.13.4.5. Zero Head • 2.8.1.5. ON Setpoint • 2.8.1.6. OFF Setpoint
Altered by	<ul style="list-style-type: none"> • 2.1.1. Units • 2.2.4. Empty
Related	<ul style="list-style-type: none"> • 2.7. Volume • 2.2.6. Blanking • 3.2.6.3. Level • 3.2.6.11. Space • 3.2.6.13. Head

Enter a value reflecting maximum application range.

Always prevent the monitored surface from approaching within 0.3 m (1 ft) of the transducer face as this is the minimum blanking for most Siemens transducers (some require more blanking – see your transducer manual).

Many other parameters are set as a percentage of span (even if they are entered in 2.1.1. Units). The values of these other parameters may change if the span is altered after installation and the other parameters are measured using a level determined upward from the Empty level toward the transducer face.

All volumes are based on span so it should be set for the maximum volume point if volume calculations are needed.

2.2.3. Transducer Selector

Sets the transducer index for all parameters applicable to this sub-menu.

2.2.4. Empty

Enters distance, in 2.1.1. Units, from the face of the transducer to the process empty point.

Index	Transducer
Values	Range: 0.000 to 99.000 m (or equivalent, depending on 2.1.1. Units)
	Preset: 5.000 m (or equivalent, depending on 2.1.1. Units)
Alters	2.2.2. Span
Altered by	2.1.1. Units
Related	<ul style="list-style-type: none"> • 2.2.6. Blanking • 3.2.6.3. Level • 3.2.6.4. Distance (%)

Setting this value also sets 2.2.2. Span, unless Span was already set to another value. For distance operation (2.1.3. Sensor Mode = Distance), Span is preset to Empty.

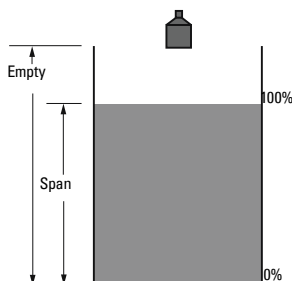

2.2.5. Sensor Offset

Calibrates 2.2.4. *Empty* if the reported level is consistently high or low by a fixed amount.

Index	Single-point model		Dual-point model	
	Global		Transducer	
Values	Range: -999 to 9999			
Related	2.2.4. <i>Empty</i> 2.12.6. <i>Offset Reading</i> 2.13.4.5. <i>Zero Head</i>		2.11.1.9. <i>Offset Correction</i> 2.11.1.3. <i>Process Temperature</i>	

Before using this feature, verify the following parameters are correct:

- 2.2.4. *Empty*
- 2.11.1.3. *Process Temperature*
- 2.12.6. *Offset Reading*
- 2.13.4.5. *Zero Head*, if using OCM

Offset Calibration

Begin with a steady level.

Step 1. Measure the actual reading (use tape measure).

Step 2. Enter the measured value from Step 1 into this parameter.

The deviation between the entered 2.2.4. *Empty* value and the calibrated **Empty** value is stored in 2.11.1.9. *Offset Correction*.

2.2.6. Blanking

The space near the transducer face which cannot be measured.

Index	Single-point model		Dual-point model	
	Global		Transducer	
Values	Range: 0.000 to 99.00 m or equivalent, depending on 2.1.1. <i>Units</i>			
	Preset	0.300 m (Most transducers)		
		0.450 m (XCT-8, XCT-12)		
Related	<ul style="list-style-type: none"> • 2.2.4. <i>Empty</i> • 2.2.2. <i>Span</i> • 2.11.3.7. <i>TVT dB</i> 			

Use this feature if the surface is reported to be near the transducer face but is in fact much further away. Extend this value when changing transducer location, mounting, or aiming.

Please note that changing the Blanking cannot correct measurement problems. Ensure that 2.2.2. *Span* < 2.2.4. *Empty* minus 2.2.6. *Blanking*.

2.2.7. Range Extension

Allows the material level to fall below the *Empty* setting without reporting LOE.

Index	Single-point model		Dual-point model	
	Global		Transducer	

Values	Range: 0.000 to 99.00 m, or max. <i>2.2.2. Span</i> , or equivalent, depending on <i>2.1.1. Units</i>
	Preset: 20% of <i>2.2.2. Span</i>
Related	<ul style="list-style-type: none"> • <i>2.1.1. Units</i> • <i>2.2.4. Empty</i> • <i>2.2.2. Span</i> • <i>2.1.5. Transducer</i>

This feature is useful in OCM applications where the Empty level is set to the bottom of the weir, and above the bottom of the channel, and should be used if the surface monitored can fall past the *2.2.4. Empty* level in normal operation. The value is added to *2.2.4. Empty* and can be greater than the range of the transducer. If the surface monitored can extend beyond *2.2.4. Empty*, increase *2.2.7. Range Extension* (in *2.1.1. Units*) such that Empty plus Range Extension is greater than the transducer face to furthest surface to be monitored distance. This is often the case with OCM when using weirs and some flumes.

2.3. Rate

2.3.1. Transducer Selector

Sets the transducer index for all parameters applicable to this sub-menu.

2.3.2. Fill Rate/minute

*Adjusts the device's response to increases in the actual material level (or advance to a higher *2.4.5. Material Level*).*

Index	Single-point model	Dual-point model
		Global
Values	Range: 0.000 to 99.00 m (or equivalent, depending on <i>2.1.1. Units</i>)	
Altered by	<i>2.3.4. Response Rate</i>	
Related	<ul style="list-style-type: none"> • <i>2.1.1. Units</i> • <i>2.2.2. Span</i> • <i>2.4.5. Material Level</i> 	

Enter a value slightly greater than the maximum vessel filling rate. This value, in *2.1.1. Units* per minute, is automatically altered when *2.3.4. Response Rate* is altered.

<i>2.3.4. Response Rate Value</i>	Meters/minute
1	0.1
2	1
3	10

2.3.3. Empty Rate/minute

*Adjusts the device's response to decreases in the actual material level (or advance to a lower *2.4.5. Material Level*).*

Index	Single-point model	Dual-point model
		Global

Values	Range: 0.000 to 99.00 m (or equivalent, depending on <i>2.1.1. Units</i>)
Altered by	<i>2.3.4. Response Rate</i>
Related	<ul style="list-style-type: none"> • <i>2.1.1. Units</i> • <i>2.2.2. Span</i> • <i>2.4.5. Material Level</i>

Enter a value slightly greater than the maximum vessel emptying rate. This value, in *2.1.1. Units* per minute, is automatically altered when *2.3.4. Response Rate* is altered.

<i>2.3.4. Response Rate Value</i>	Meters/minute
1	0.1
2	1
3	10

2.3.4. Response Rate

Determines the level change reaction.

Index	Transducer	
Options	Slow (0.1 m/min)	
	*Medium (1.0 m/min)	
	Fast (10.0 m/min)	
Alters	<ul style="list-style-type: none"> • <i>2.4.2. LOE Timer</i> • <i>2.3.2. Fill Rate/minute</i> • <i>2.3.3. Empty Rate/minute</i> • <i>2.3.9. Filling Indicator</i> • <i>2.3.10. Emptying Indicator</i> • <i>2.3.5. Rate Filter</i> • <i>2.11.5.6. Fuzz Filter</i> • <i>2.11.5.5. Echo Lock Window</i> • <i>2.1.14. Scan Delay</i> • <i>2.1.12. Number of Long Shots</i> 	
	Related	<ul style="list-style-type: none"> • <i>2.4.5. Material Level</i> • <i>2.4.6. Fail-safe Advance</i> • <i>2.8.1.8. Pump by Rate</i> • <i>2.3.6. Rate Filter Time</i> • <i>2.3.7. Rate Filter Distance</i> • <i>3.2.7. Pump Records</i> • <i>2.11.5.4. Echo Lock</i> • <i>2.11.5. Measurement Verification</i> • <i>2.1.13. Shot Synchro</i> • <i>2.1.16. Shot Delay</i> • <i>2.1.15. Scan Time</i>

Use a setting just fast enough to keep up with your process. Slower settings provide higher accuracy. Faster settings allow for more level fluctuations.

2.3.5. Rate Filter

Damps the 3.2.6.15. Flow Maximum fluctuations.

Index	Single-point model	Dual-point model
	Global	Transducer

Options	Rate display not required.
	Filtered Output: Continuous filtering and update
	Interval Output: *1 min or 50 mm (2 in) 5 min or 100 mm (3.9 in) 10 min or 300 mm (11.8 in) 10 min or 1000 mm (39.4 in)
Alters	<i>3.2.6.15. Flow Maximum</i>
Altered by	<i>2.3.4. Response Rate</i>
Related	<i>2.3.6. Rate Filter Time</i> <i>2.3.7. Rate Filter Distance</i>

Enter the time or distance interval over which the *3.2.6.15. Flow Maximum* is to be calculated before the display updates.

This is automatically altered along with *2.3.4. Response Rate*.

This value automatically alters the *2.3.6. Rate Filter Time* and/or *2.3.7. Rate Filter Distance*. Alternatively, these parameter values may be altered independently.

2.3.6. Rate Filter Time

The time period, in seconds, over which the material level rate of change is averaged before 3.2.6.15. Flow Maximum updates.

Index	Single-point model	Dual-point model
	Global	Transducer
Values	Range: 0.000 to 9999 seconds	
Related	<i>3.2.6.15. Flow Maximum</i>	

2.3.7. Rate Filter Distance

The material level change, in meters, to initiate a 3.2.6.15. Flow Maximum update.

Index	Single-point model	Dual-point model
	Global	Transducer
Values	Range: 0.000 to 9999 meters	
Related	<i>3.2.6.15. Flow Maximum</i>	

2.3.8. Level Selector

Sets the Level Point index for all parameters applicable to this sub-menu.

2.3.9. Filling Indicator

The fill rate required to activate the LCD Filling indicator (†).

Index	Single-point model	Dual-point model
	Global	Transducer
Values	Range: 0.000 to 99.00 m (or equivalent, depending on <i>2.1.1. Units</i>)	
Altered by	<i>2.3.4. Response Rate</i>	
Related	<ul style="list-style-type: none"> • <i>2.1.1. Units</i> • <i>2.2.2. Span</i> • <i>2.3.2. Fill Rate/minute</i> 	

This value (in 2.1.1. Units per minute) is automatically set to 1/10 of the 2.3.2. Fill Rate/minute.

2.3.10. Emptying Indicator

The empty rate required to activate the LCD emptying indicator (↕).

Index	Single-point model	Dual-point model
	Global	Transducer
Values	Range: 0.000 to 99.00 m (or equivalent, depending on 2.1.1. Units)	
Altered by	2.3.4. Response Rate	
Related	<ul style="list-style-type: none"> • 2.1.1. Units • 2.2.2. Span • 2.3.3. Empty Rate/minute 	

This value (in 2.1.1. Units per minute) is automatically set to 1/10 of the 2.3.3. Empty Rate/minute.

2.4. Fail-safe

The fail-safe parameters ensure that the devices controlled by the HydroRanger default to an appropriate state when a valid level reading is not available. The Primary Reading region on the HMI will display dashes (----) until the fail-safe fault has been cleared. (See General fault codes on page 213 for a list of faults that will cause fail-safe.)

Note: When a Loss of Echo occurs, 2.4.5. Material Level determines the material level to be reported when the Fail-safe timer expires. For more details, see Fail-safe Mode on page 240 of Appendix A: Technical reference.

2.4.1. Transducer Selector

Sets the transducer index for all parameters applicable to this sub-menu.

2.4.2. LOE Timer

The time for invalid measurements to elapse before a fail-safe state activates.

Index	Single-point model	Dual-point model
	Global	Transducer
Values	Range: 0 to 15 minutes	
	Preset 10.00 minutes	
Altered by	2.3.4. Response Rate	
Related	2.8.2.3. Relay Fail-safe	

Once activated, the fail-safe state initiates the following:

1. The material level is reported based on 2.4.5. Material Level.
 - The unit responds to the new level as programmed (control and alarm relays activate as defined by the programming).
 - Individual relays can have independent fail-safe responses. See 2.8.2.3. Relay Fail-safe.
2. The appropriate error is displayed:

- **LOE** for loss of echo from the transducer.
- **Short** for a shorted transducer cable.
- **Open** for a cut transducer cable.
- **Error** for all other problems.

When modifying the preset value, set it short enough to protect the process, but long enough to avoid false alarms. Only use **0.0 minutes (no delay)** for testing.

2.4.3. Level Selector

Sets the Level Point index for all parameters applicable to this sub-menu.

2.4.4. Fail-safe Mode

Sets how the HydroRanger responds to a fail-safe state.

Index	Transducer	
Options	HI	Level goes to maximum 2.2.2. <i>Span</i> .
	LO	Level goes to 0 span (2.2.4. <i>Empty</i>).
	*Hold	Level remains at last reading.
	Value	Level goes to user-selected value defined in 2.4.5. <i>Material Level</i> .
Related	<ul style="list-style-type: none"> • 2.1.3. <i>Sensor Mode</i> • 2.2.4. <i>Empty</i> • 2.2.2. <i>Span</i> • 2.8.1.4. <i>Relay Function</i> • 2.8.1.5. <i>ON Setpoint</i> • 2.8.1.6. <i>OFF Setpoint</i> • 2.8.2.3. <i>Relay Fail-safe</i> 	

Select the Fail-safe Mode based on the relay operation required during fail-safe operation.

Relay reaction

The way in which relay programming reacts to the fail-safe level depends on 2.8.2.3. *Relay Fail-safe*. By default:

- Alarm relays have 2.8.2.3. *Relay Fail-safe* = **OFF** and so react to the Material Level.
- Control relays have 2.8.2.3. *Relay Fail-safe* = **De-energize** and so de-energize the relay when the unit enters Fail-safe mode regardless of the Material Level.

2.4.5. Material Level

The material level reported when a fail-safe state is initiated.

Index	Transducer
Values	Range: -4999 to 9999, value in 2.1.1. <i>Units</i>

2.4.6. Fail-safe Advance

Sets the speed the HydroRanger advances to, and returns from, the Fail-safe Material Level.

Index	Level	
Options	*Restricted	Advances to/from Fail-safe Material Level as set by 2.3.4. Response Rate, 2.3.2. Fill Rate/minute, and 2.3.3. Empty Rate/minute.
	Immediate	Fail-safe Material Level assumed right away.
	Fast Back	Fail-safe Level Advance is restricted, return is immediate.
Related	<ul style="list-style-type: none"> • 2.3.4. Response Rate • 2.4.2. LOE Timer • 2.4.5. Material Level • 2.3.2. Fill Rate/minute • 2.3.3. Empty Rate/minute 	

2.4.7. mA Output Selector

Sets the mA Output index for all applicable parameters in this sub-menu.

Options	*mA Output 1
	mA Output 2

2.4.8. mA Fail-safe Mode

Use for fail-safe operation, independent of the 2.4.5. Material Level.

Index	mA Output	
Options	*OFF	mA output responds to 2.4.5. Material Level.
	HI	Produce the Span mA output immediately.
	LO	Produce the Empty mA output immediately.
	Hold	Last known value is held until normal operation resumes.
	Value	mA output goes to user-selected value defined in 2.4.9. mA Fail-safe Value.
Related	2.5.3. Current Output Function	

2.4.9. mA Fail-safe Value

Sets the mA value to be reported when the fail-safe timer expires.

Note: 2.4.4. Fail-safe Mode must be set to **Value** in order for the **Material Level** value to be reported.

Index	mA Output
Values	Range: 0 to 22 mA
	Preset: 3.58 mA

2.5. Current Output

Sets the parameters applicable to the current value of the mA output.

2.5.1. mA Output Selector

Sets the mA output index for all parameter settings.

Options	*mA Output 1
	mA Output 2

2.5.2. mA Output Range

Determines the mA output range.

Index	mA Output
Options	OFF
	0 to 20 mA
	*4 to 20 mA
	20 to 0 mA
	20 to 4 mA
Related	<i>2.5.9. Milliamp Output</i>

If either 0 to 20 mA or **4 to 20 mA** is selected, the mA output is directly proportional to the mA Function. If either 20 to 0 mA or 20 to 4 mA is selected, then the output is inversely proportional. After setting *2.5.2. mA Output Range*, verify that *2.5.7. Minimum mA Limit* has a valid entry, as it is not changed automatically by setting the *2.5.2. mA Output Range*.

2.5.3. Current Output Function

Alters the mA output/measurement relationship.

Index	mA Output	
Options	mA function <i>2.1.3. Sensor Mode</i>	
	OFF	
	Level	Level, differential, or average
	Space	Space
	*Distance	Distance
	Volume	Level or space
	Flow	OCM
	Head	
	Volume Rate	
	mA Input	
	Comms Input	
Related	<ul style="list-style-type: none"><i>2.5.4. mA Output Allocation</i><i>2.5.9. Milliamp Output</i>	
Altered by	<i>2.1.3. Sensor Mode</i>	

2.5.4. mA Output Allocation

Sets the input source from which the mA output is calculated.

Index	mA Output
--------------	-----------

Options	*Point 1
	Point 2
	Average of readings from Point 1 and Point 2
	Point 3
Related	2.5.3. <i>Current Output Function</i>

Enter the point number the mA output is based on. This value depends on whether 2.5.3. *Current Output Function* is set as transducer or mA input.

For a single-point device, if 2.5.3. *Current Output Function* uses a transducer, parameter 2.5.4. *mA Output Allocation* can only be altered if 2.1.3. *Sensor Mode* is set for DPD or DPA.

Parameter 2.5.4. *mA Output Allocation* can be set to a particular point or range of points. When set to a range of points, the mA output will be the average of the readings from all in service transducers in the range. Out-of-service transducers will be ignored.

2.5.5. 4 mA Setpoint

Sets the process level corresponding to the 0 or 4 mA value.

Index	mA Output
Values	Range: -999 to 9999
Related	2.5.6. <i>20 mA Setpoint</i>

Enter the value (in applicable 2.1.1. *Units*) to correspond to 0 or 4 mA.

2.5.6. 20 mA Setpoint

Sets the process level that corresponds to the 20 mA value.

Index	mA Output
Values	Range: -999 to 9999
Related	2.5.5. <i>4 mA Setpoint</i>

Enter the value (in applicable 2.1.1. *Units*) to correspond to 20 mA.

2.5.7. Minimum mA Limit

Sets the minimum mA output value to be produced.

Index	mA Output
Values	Range: 0.000 to 22.000 mA
	Preset: 3.800 mA
Related	<ul style="list-style-type: none"> • 2.5.2. <i>mA Output Range</i> • 2.5.8. <i>Maximum mA Limit</i>

2.5.8. Maximum mA Limit

Sets the maximum mA output value to be produced.

Index	mA Output
Values	Range: 0.000 to 22.000 mA
	Preset: 20.200 mA
Related	<ul style="list-style-type: none"> • 2.5.2. <i>mA Output Range</i> • 2.5.7. <i>Minimum mA Limit</i>

2.5.9. Milliamp Output

Displays the current mA output value.

Values	Range: 3.500 to 22.2 mA
---------------	-------------------------

2.5.10. Fail-safe Mode

Use for fail-safe operation, independent of the 2.4.5. Material Level.

Index	mA Output	
Options	*OFF	mA output responds to 2.4.5. <i>Material Level</i> .
	HI	Produce the Span mA output immediately.
	LO	Produce the Empty mA output immediately.
	Hold	Last known value is held until normal operation resumes.
	Value	mA output goes to user-selected value defined in 2.4.9. <i>mA Fail-safe Value</i> .
Related	2.5.3. <i>Current Output Function</i>	

2.5.11. 4 mA Output Trim

Calibrates the 4 mA output.

Index	mA Output
Values	Preset: 4.00
Related	2.5.12. <i>20 mA Output Trim</i>

Adjust this value so the device indicates 4.00 mA when 2.5.11. *4 mA Output Trim* is accessed.

Trimming the 4 mA value:

1. Go to 2.5.9. *Milliamp Output* and enter 4.00 mA.
2. Read the value indicated on the current meter or other connected device, and enter it in 2.5.11. *4 mA Output Trim*.

The new **trimmed value** will be shown in the current meter or other connected device.

2.5.12. 20 mA Output Trim

Calibrates the 20 mA output.

Index	mA Output
Values	Preset: 20.00
Related	2.5.11. <i>4 mA Output Trim</i>

Adjust this value so the device indicates 20.00 mA when 2.5.12. *20 mA Output Trim* is accessed.

Trimming the 20 mA value:

1. Go to 2.5.9. *Milliamp Output* and enter 20.00 mA.
2. Read the value indicated on the current meter or other connected device, and enter it in 2.5.12. *20 mA Output Trim*.

The new **trimmed value** will be shown in the current meter or other connected device.

2.6. Current Input

2.6.1. mA Input Range

Shows the mA input range of the connected mA device.

Index	Global
Options	0 to 20 mA
	*4 to 20 mA

Ensure this range corresponds to the output range of the external device. All level measurements will equate % of Span with the % of the mA range.

2.6.2. 0/4 mA Level Value

Shows the process level corresponding to the 0 or 4 mA value.

Index	Global
Values	Range: -999 to 9999%
	Preset: 0%
Related	<ul style="list-style-type: none">• 2.2.4. Empty• 2.2.2. Span

When using an external mA signal to determine level, the input range must be scaled to give accurate results.

2.6.3. 20 mA Level Value

Shows the process level corresponding to the 20 mA value.

Index	Global
Values	Range: -999 to 9999%
	Preset: 100%
Related	<ul style="list-style-type: none">• 2.2.4. Empty• 2.2.2. Span

Input range is scaled for accuracy if an external mA signal calculates level.

2.6.4. mA Damp Filter

Shows the time constant used in the mA input filter to dampen signal fluctuations.

Index	Global
Values	Range: 0 to 9999 seconds
	Preset: 1 second

This number is used in the damping calculations. Larger values damp more than smaller values and **0** disables the signal filter.

2.6.5. Scaled mA Input Value

Shows the resulting level value after scaling.

Index	Global
Values	Range: -999 to 9999% (Read only)
	Preset: calculated from the input mA signal

2.6.6. Raw mA Input Value

Shows the raw mA input supplied by an external device.

Index	mA Input
Values	Range: 0.000 to 20.00 (Read only)

2.7. Volume

Carries out a volume conversion from a Level measurement.

2.7.1. Level Selector



Sets the Level Point index for all parameters applicable to this sub-menu.

2.7.2. Vessel Shape

Enters the Vessel Shape value matching the monitored vessel or wet well.

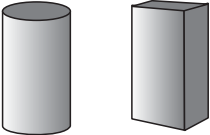
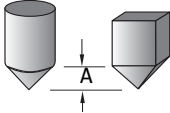
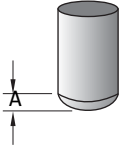
Liquid (material) volume is calculated when 2.1.3. *Sensor Mode* = *Level. Alternatively, the remaining vessel capacity is calculated when 2.1.3. *Sensor Mode* =Space. In RUN mode, readings are displayed in percent of maximum volume. To convert readings to volumetric units, see 2.7.3. *Maximum Volume*.

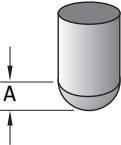
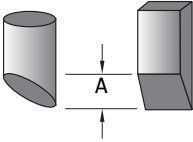
Vessel Shape	LCD DISPLAY/ Description
None	* None
	Flat Level Bottom
	Conical Bottom
	Parabolic Bottom

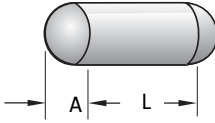
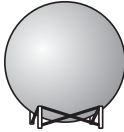
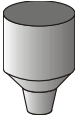
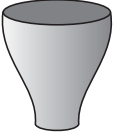
Vessel Shape (Continued)	LCD DISPLAY/ Description
	Half Sphere Bottom
	Flat Sloped Bottom
	Flat Ends
	Parabolic Ends
	Sphere
	Universal Linear
	Universal Curved

2.7.3. Maximum Volume

Enters the maximum volume of the vessel.

Index	Level
Values	Range: 0.000 to 99999
	Preset: 100.000
Alters	<i>2.12.4. Decimal Position</i>
Related	<ul style="list-style-type: none">• <i>2.2.4. Empty</i>• <i>2.2.2. Span</i>• <i>3.2.6.13. Head</i>

Enter the vessel volume corresponding to *2.2.2. Span*. For example, if your maximum vessel volume is 8000 L, enter a value of 8000.

For readings in volumetric units (rather than percent), enter the equivalent vessel volume for *2.2.2. Span*.

Any volume units can be chosen because volume is calculated from empty to maximum span, and is scaled according to the *2.7.2. Vessel Shape* value.

Note: Make sure selected chosen units allow LCD volume display.

Examples:

- If max. volume = 3650 m³, enter 3650
- If max. volume = 267500 gallons, enter 267.5 (thousands of gallons)

2.7.4. Dimension A

Enters the height of the vessel bottom when the bottom is conical, parabolic, spherical, or flat sloped. If the vessel is horizontal with parabolic ends, the depth of the end. See 2.7.2. Vessel Shape on page 140 for illustrations.

Dimension A as used in *2.7.2. Vessel Shape*.

Index	Level
Values	Range: 0.000 to 99.000 m or equivalent, depending on <i>2.1.1. Units</i>
	Preset: 0.000
Related	<i>2.7.2. Vessel Shape</i>

Enter one of the following:

- Height of the tank bottom, if *2.7.2. Vessel Shape* = Conical Bottom, Parabolic Bottom, Half Sphere Bottom, or Flat Sloped Bottom,
or
- Length of one end section of the tank, if *2.7.2. Vessel Shape* = Parabolic Ends , in *2.1.1. Units*.

2.7.5. Dimension L

Enters the length of the cylindrical section of a horizontal parabolic end vessel.
See 2.7.2. Vessel Shape on page 140 for illustrations.

Dimension L as used in 2.7.2. Vessel Shape.

Index	Level
Values	Range: 0.000 to 99.000 m or equivalent, depending on 2.1.1. Units
	Preset: 0.000
Related	2.7.2. Vessel Shape

Enter the tank length (excluding both end sections) if 2.7.2. Vessel Shape = Parabolic Ends.

2.7.6. Transducer Selector

Sets the transducer index for all parameters applicable to this sub-menu.

2.7.7. Inflow/discharge Adjust

The method used to calculate the volume pumped, for pumped total (2.1.3. Sensor Mode = Pump Totalizer).

Index	Single-point model	Dual-point model
	Global	
Options	Based on Pump Cycle	
	No adjustment	
	*Based on Rate Estimation	
Related	<ul style="list-style-type: none">• 2.1.3. Sensor Mode• 2.3.5. Rate Filter• 2.3.6. Rate Filter Time• 2.3.7. Rate Filter Distance• 3.2.7. Pump Records	

2.7.8. Table 1-8

Allows for the Volume to be specified based on segments, if the tank shape is too complex for any of the preconfigured shapes.

Enter up to 32 Level and Volume breakpoints (where Volume is known), if 2.7.2. Vessel Shape is set to Universal Linear or Universal Curved.

Each segment defined by the Level breakpoints (example: Level 1) requires a Volume (example: Volume 1) for the level-to-volume calculations.

2.7.8.1. Level 1

2.7.8.2. Volume 1

2.7.8.3. Level 2

2.7.8.4. Volume 2

2.7.8.5. Level 3

2.7.8.6. Volume 3

2.7.8.7. Level 4

2.7.8.8. Volume 4

2.7.8.9. Level 5

2.7.8.10. Volume 5

- 2.7.8.11. Level 6**
- 2.7.8.12. Volume 6**
- 2.7.8.13. Level 7**
- 2.7.8.14. Volume 7**
- 2.7.8.15. Level 8**
- 2.7.8.16. Volume 8**

2.7.9. Table 9-16

- 2.7.9.1. Level 9**
- 2.7.9.2. Volume 9**
- 2.7.9.3. Level 10**
- 2.7.9.4. Volume 10**
- 2.7.9.5. Level 11**
- 2.7.9.6. Volume 11**
- 2.7.9.7. Level 12**
- 2.7.9.8. Volume 12**
- 2.7.9.9. Level 13**
- 2.7.9.10. Volume 13**
- 2.7.9.11. Level 14**
- 2.7.9.12. Volume 14**
- 2.7.9.13. Level 15**
- 2.7.9.14. Volume 15**
- 2.7.9.15. Level 16**
- 2.7.9.16. Volume 16**

2.7.10. Table 17-24

- 2.7.10.1. Level 17**
- 2.7.10.2. Volume 17**
- 2.7.10.3. Level 18**
- 2.7.10.4. Volume 18**
- 2.7.10.5. Level 19**
- 2.7.10.6. Volume 19**
- 2.7.10.7. Level 20**
- 2.7.10.8. Volume 20**
- 2.7.10.9. Level 21**
- 2.7.10.10. Volume 21**
- 2.7.10.11. Level 22**
- 2.7.10.12. Volume 22**
- 2.7.10.13. Level 23**
- 2.7.10.14. Volume 23**
- 2.7.10.15. Level 24**

2.7.10.16. Volume 24

2.7.11. Table 25- 32

2.7.11.1. Level 25

2.7.11.2. Volume 25

2.7.11.3. Level 26

2.7.11.4. Volume 26

2.7.11.5. Level 27

2.7.11.6. Volume 27

2.7.11.7. Level 28

2.7.11.8. Volume 28

2.7.11.9. Level 29

2.7.11.10. Volume 29

2.7.11.11. Level 30

2.7.11.12. Volume 30

2.7.11.13. Level 31

2.7.11.14. Volume 31

2.7.11.15. Level 32

2.7.11.16. Volume 32

2.8. Relays

2.8.1. Basic Setup

2.8.1.1. Relay Selector

Sets the relay index for all parameters applicable to this sub-menu.

Options	*Relay 1
	Relay 2
	Relay 3
	Relay 4
	Relay 5
	Relay 6

2.8.1.2. Level Source

Sets the level source for the indexed relay.

Index	Relays
Options	*Transducer 1
	Transducer 2
	Difference or Average
Altered by	<ul style="list-style-type: none">• 2.3.4. Response Rate• 2.3.2. Fill Rate/minute• 2.3.3. Empty Rate/minute• 2.4.2. LOE Timer• 2.4.5. Material Level

2.8.1.3. Preset Applications

Selects the preset options to configure or bench test the unit.

Index	Global
Options	*OFF
	Wet Well 1
	Wet Well 2
	Reservoir 1
	Reservoir 2
	Screen
	Alarms
Alters	<ul style="list-style-type: none">• 2.8.1.2. Level Source• 2.8.1.4. Relay Function• 2.8.1.5. ON Setpoint• 2.8.1.6. OFF Setpoint• 2.8.1.8. Pump by Rate
Related	2.1.3. Sensor Mode

Notes:

- For detailed descriptions of the various Preset Applications, see page 64 of *General operation*.
- Before selecting a Preset Application, a **Level, Volume** or **Flow** Quick Start Wizard must first be completed.

Select an application that is similar to yours and change the parameters required. If nothing suits your application, refer to *2.8.1.4. Relay Function* on page 147.

2.8.1.4. Relay Function

Sets the control algorithm used to trip the relay.

Index	Relay
Options	See chart below.
Altered by	2.8.1.3. Preset Applications

Note: All relay ON/OFF points must be referenced from 2.2.4. *Empty* (bottom of the vessel), regardless of 2.1.3. *Sensor Mode* selection.

Control	Type	Relay Control
	*OFF	Relay set off, no action (preset).
	Level	Based on level setpoints ON and OFF.
Alarm	Low Low Alarm	
	Low Alarm	
	High Alarm	
	High High Alarm	
General	In-bounds	When level enters the range between ON and OFF setpoints.
	Out-of-bounds	When level exits the range between ON and OFF setpoints.
	Rate of Change	Based on rate setpoints ON and OFF.
	Temperature	Based on temperature setpoints ON and OFF.
	LOE	Loss of echo; when echo is lost.
	Cable Fault	When the circuit to a transducer is opened.
Flow	Totalizer	Every 10^y units (2.10.2.2. <i>Mantissa</i> -2.10.2.4. <i>Relay Duration</i>).
	Flow Sampler	Every $y \times 10^2$ units (2.10.2.2. <i>Mantissa</i> -2.10.2.4. <i>Relay Duration</i>) or time duration (2.10.2.6. <i>Relay Interval Setpoint</i>).

Control	Type	Relay Control
Pump	Fixed Duty Assist	At fixed ON and OFF setpoints and allows multiple pumps to run or for rake control.
	Fixed Duty Backup	At fixed ON and OFF setpoints and allows only one pump to run.
	Alternate Duty Assist	At rotating ON and OFF setpoints and allows multiple pumps to run.
	Alternate Duty Backup	At rotating ON and OFF setpoints and allows only one pump to run.
	Service Ratio Duty Assist	On service ratio at ON and OFF setpoints and allows multiple pumps to run.
	Service Ratio Duty Backup	On service ratio at ON and OFF setpoints and allows only one pump to run.
	First In First Out	As Alternate Duty Assist, resets the relay from staggered OFF setpoints.
Control	Flush Valve	Used to control a pump flushing device based on Flush Systems (2.10.3.2. <i>Flush Pump</i> to 2.10.3.5. <i>Flush Duration</i>).
	Communication	Based on input from external communications. See 5.4. <i>Communications Control</i> on page 205 for further reference.

2.8.1.5. ON Setpoint

Sets the process point at which the relay changes from its Normal state.

Index	Relay
Values	Range: -999 to 9999
	Preset: ----
Altered by	2.2.2. <i>Span</i>
Related	<ul style="list-style-type: none"> • 2.8.1.4. <i>Relay Function</i> • 2.8.1.6. <i>OFF Setpoint</i> • 2.8.1.3. <i>Preset Applications</i>

For most applications, the relay is tripped at this point. For In-bounds and Out-of-bounds alarms, it is the high point in the specified range. This parameter is set according to 2.2.2. *Span* even when another reading, such as volume, is shown on the LCD.

2.8.1.6. OFF Setpoint

Sets the process point at which the relay returns to its Normal state.

Index	Relay
Values	Range: -999 to 9999
	Preset: ----
Altered by	2.2.2. <i>Span</i>
Related	<ul style="list-style-type: none"> • 2.8.1.4. <i>Relay Function</i> • 2.8.1.5. <i>ON Setpoint</i> • 2.8.1.3. <i>Preset Applications</i>

For most applications, the relay is reset at this point. For In-bounds and Out-of-bounds alarms, it is the low point in the specified range. This parameter is set to 2.2.2. *Span*, even when another reading, such as volume, is shown on the LCD.

2.8.1.7. Level Selector

Sets the Level Point index for all parameters applicable to this sub-menu.

2.8.1.8. Pump by Rate

Sets the pump relays to accept control by rate of level change once the first ON setpoint is reached.

Index	Single-point model	Dual-point model
		Transducer
Options	*OFF (pump by level)	
	ON	
Related	<ul style="list-style-type: none"> • 2.2.2. <i>Span</i> • 2.8.1.4. <i>Relay Function</i> • 2.8.2.8.1. <i>Delay Between Starts</i> • 2.3. <i>Rate</i> • 3.2.7. <i>Pump Records</i> 	

Use this function when multiple pumps are to be controlled by rate of level change rather than by setpoints.

The delay between pump starts is set by 2.8.2.8.1. *Delay Between Starts*.

This only applies to any relays set to pump control (2.8.1.4. *Relay Function* = Fixed Duty Assist, Fixed Duty Backup, Alternate Duty Assist, Alternate Duty Backup, Service Ratio Duty Assist, Service Ratio Duty Backup, or First In First Out).

Notes:

- All pump control relay ON and OFF setpoints must be the same value.
- If the level is within 5% of 2.2.2. *Span* of the OFF setpoint, the next pump is not started.

2.8.1.9. Filling Indicator

Sets the fill rate required to activate the LCD Filling indicator (↑).

Index	Single-point model	Dual-point model
		Global
Values	Range: 0.000 to 99.00 m (or equivalent, depending on units)	
Altered by	2.3.4. <i>Response Rate</i>	
Related	<ul style="list-style-type: none"> • 2.1.1. <i>Units</i> • 2.2.2. <i>Span</i> • 2.3.2. <i>Fill Rate/minute</i> 	

This value (in 2.1.1. *Units* per minute) is automatically set to 1/10 of 2.3.2. *Fill Rate/minute*.

2.8.1.10. Emptying Indicator

Sets the empty rate required to activate the LCD emptying indicator (↕).

Index	Single-point model	Dual-point model
	Global	Transducer
Values	Range: 0.000 to 99.00 m (or equivalent, depending on units)	
Altered by	2.3.4. Response Rate	
Related	<ul style="list-style-type: none">• 2.1.1. Units• 2.2.2. Span• 2.3.3. Empty Rate/minute	

This value (in 2.1.1. Units per minute) is automatically set to 1/10 of 2.3.3. Empty Rate/minute.

2.8.1.11. Relay Logic

Sets the logic applied to relays to determine the contact Open or Closed state.

Index	Relay		
Options	Logic	Alarm Contact	Pump or Control Contact
	*Positive	Normally Closed	Normally Open
	Negative	Normally Open	Normally Closed
Related	2.8.1.4. Relay Function		

The relay contact operation is Normally Closed for alarms and Normally Open for controls. See 2.8.1.4. Relay Function for more information.

Note: This parameter is not reset by 3.2.1. Master Reset.

Power Failure

When power is cut to the HydroRanger, its relays fail to the following states:

Relay States	
Relay	Fail State
1,2,4,5	Open
3,6	Open or Closed ¹

¹ Relays 3 and 6 are Form C types, so you can wire it either Normally Open or Normally Closed. Check the wiring before programming.

To use Relays 3 or 6 as general alarm indicators, set 2.8.1.11. Relay Logic to **Negative** and wire the alarm for **Normally Open** operation. When an alarm event occurs (see below) or when power is cut, the circuit closes and the alarm activates.

Positive Logic

In software, all relays are programmed the same way, with ON setpoints indicating when to change the relay contact state (open or

closed). This parameter allows the reversal of the operation so that relay contacts can be **Normally Closed** or **Normally Open**. 2.8.1.11. *Relay Logic* is preset to **Positive** logic.

Negative Logic

When 2.8.1.11. *Relay Logic* = **Negative** logic, the operation for the indexed relay is reversed from normal.

2.8.1.12. Service Ratio

*Selects pump usage based on the **RUN time** ratio rather than **Last used**.*

Index	Relay
Values	Range: 0.000 to 9999
	Preset: 20.000
Related	2.8.1.4. <i>Relay Function</i>

This parameter only applies to relays with 2.8.1.4. *Relay Function* = Service Ratio Duty Assist or Service Ratio Duty Backup.

To make this parameter useful, assign it to all of the pump relays. The number assigned to each pump relay represents the ratio applied to decide the next pump to start or stop.

Notes:

- The HydroRanger will not sacrifice other pumping strategies to ensure that the ratio is held true.
- If the pump relays are set to the same value, then the ratio equals 1:1 and all pumps are used equally (preset).

2.8.2. Modifiers

Provides alternate ways of starting the pumps in the pump group.

2.8.2.1. Relay Selector

Sets the relay index for all parameters applicable to this sub-menu.

2.8.2.2. Pump Group

Organizes pumps into groups, for multiple pump rotations on one transducer.

Index	Relay
Options	*Group 1
	Group 2
Alters	2.8.1.4. <i>Relay Function</i> , when 2.8.1.4. <i>Relay Function</i> = Alternate Duty Assist or Alternate Duty Backup

This feature groups pumps (Relay Points 1 - 6) into Groups 1 or 2. It is applied to pump rotation and occurs independently within each group.

2.8.2.3. Relay Fail-safe

Sets how individual relays react to a fail-safe condition, to allow for more flexible programming.

Index	Relay	
Options	OFF	Response governed by 2.4.5. <i>Material Level</i> .
	Hold	Last known relay state retention.
	Energize	To have the relay energize immediately on fail-safe.
	De-energize	To have the relay de-energize immediately on fail-safe.
Altered by	2.4.5. <i>Material Level</i>	
Related	<ul style="list-style-type: none"> • 2.4.2. <i>LOE Timer</i> • 2.8.1.4. <i>Relay Function</i> 	

Use this for operations independent of the 2.4.5. *Material Level*.

Relay Fail-safe is **available only** for the relay functions listed in the table below. Preset options depend on the relay functions selected.

2.8.1.4. <i>Relay Function</i>	Preset (2.8.2.3. <i>Relay Fail-safe</i>)
Level alarm	OFF
In-bounds alarm	
Out-of-bounds alarm	
Rate of Change alarm	
Temperature alarm	
Fixed Duty Assist, Fixed Duty Backup, Alternate Duty Assist, Alternate Duty Backup, Service Ratio Duty Assist, Service Ratio Duty Backup, First In First Out: all pump controls	De-energize

2.8.2.4. Relay Interval Setpoint

Sets the length of time, in hours, between starts.

Index	Relay
Values	Range: 0 to 9000 hours
	Preset: 0.000 hours
Altered by	2.8.1.3. <i>Preset Applications</i>
Related	2.8.1.4. <i>Relay Function</i>

2.8.2.5. Relay Dead Band

Sets the distance above and below the bound alarm setpoints.

Index	Relay
Values	Range: 0.000 to 2.2.2. <i>Span</i> value, or equivalent, depending on 2.1.1. <i>Units</i> .
	Preset: 2% of 2.2.2. <i>Span</i> .
Related	<ul style="list-style-type: none"> • 2.8.1.4. <i>Relay Function</i> • 2.8.1.5. <i>ON Setpoint</i> • 2.8.1.6. <i>OFF Setpoint</i>

Note: This parameter applies only to in-bounds and out-of-bounds relay functions.

For In-bounds and Out-of-bounds Relay Functions (2.8.1.4. *Relay Function*= In-bounds and Out-of-bounds, respectively), a dead band prevents relay chatter due to material level fluctuations at both the upper and lower setpoints.

Enter the dead band in units of measure (2.1.1. *Units*). The dead band value is applied both above and below the upper and lower bound setpoints as shown in the figure.

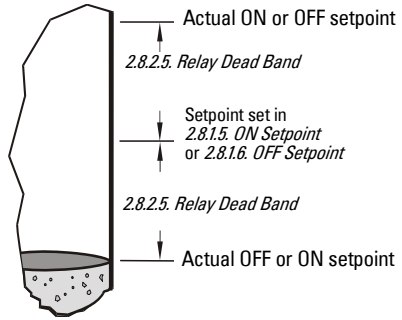

2.8.2.6. Wall Cling Reduction

2.8.2.6.1. Transducer Selector

Sets the transducer index for all parameters applicable to this sub-menu.

2.8.2.6.2. Level Setpoint Variation

Varies the ON and OFF setpoints to reduce material buildup on the walls (defined in 2.1.1. Units).

Values	Range: 0.000 to 99999.000
	Default: 0.000

This value is the range in which the setpoints are allowed to deviate. The pump ON and OFF Setpoint values are randomly varied inside the range to ensure that the material level does not consistently stop at the same point.

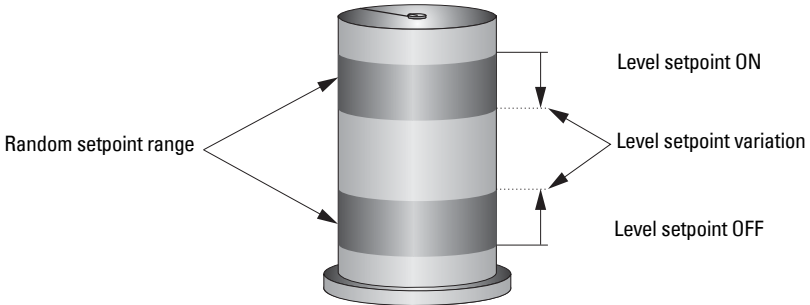

Advanced pump control modifiers

The following parameters from 2.8.2.7. *Pump Run-ON* to 2.8.2.8.2. *Power Resumption Delay* affect only the relays set to Pump Control in 2.8.1.4. *Relay Function*. See the **Pump** row in the **Control** column of the chart on page 147 for details.

2.8.2.7. Pump Run-ON

2.8.2.7.1. Run-ON Interval

Sets the number of hours between pump Run-ON occurrences.

Index	Global
Values	Range: 0.000 to 1000
	Preset: 0.000
Related	<ul style="list-style-type: none">• 2.8.2.7.3. <i>Run-ON Duration</i>• 2.8.2.8.1. <i>Delay Between Starts</i>• 2.8.2.8.2. <i>Power Resumption Delay</i>• 2.8.2.6.2. <i>Level Setpoint Variation</i>

To clear sediment in a pump-down wet well, run the pump after the normal OFF setpoint is reached to force some solid material through. This parameter sets the time between such events. Only the last pump running can run-ON.

2.8.2.7.2. Relay Selector

Sets the relay index for all parameters applicable to this sub-menu.

2.8.2.7.3. Run-ON Duration

Sets the number of seconds that the pump runs ON.

Index	Relay
Values	Range: 0.0 to 9999 seconds
	Preset: 0.000 seconds
Related	<ul style="list-style-type: none">• 2.8.2.7.1. <i>Run-ON Interval</i>• 2.8.2.8.1. <i>Delay Between Starts</i>• 2.8.2.8.2. <i>Power Resumption Delay</i>• 2.8.2.6.2. <i>Level Setpoint Variation</i>

Your pump capacity determines the amount of material that can be removed. Choose a value long enough to clean out the vessel bottom, yet short enough not to run the pump dry. Also be sure that this value does not overlap with 2.8.2.7.1. *Run-ON Interval*. The timing should look like this:

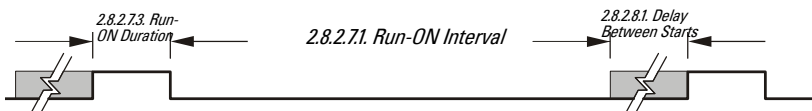

2.8.2.8. Pump Start Delays

Sets when the pumps are permitted to start. Use this feature to reduce power surge by not having all the pumps start at the same time.

2.8.2.8.1. Delay Between Starts

Sets the minimum delay (in seconds) between pump starts. This delay determines when the next pump is permitted to start.

Index	Global
Values	Range: 0.0 to 9999
	Preset: 10 seconds
Related	<ul style="list-style-type: none">• 2.8.2.7.1. Run-ON Interval• 2.8.2.8.2. Power Resumption Delay• 2.8.2.6.2. Level Setpoint Variation• 2.8.1.8. Pump by Rate

2.8.2.8.2. Power Resumption Delay

Sets the minimum delay before the first pump restarts after power failure.

Index	Global
Values	Range: 0.000 to 9999
	Preset: 10 seconds
Related	<ul style="list-style-type: none">• 2.8.2.7.1. Run-ON Interval• 2.8.2.6.2. Level Setpoint Variation• 2.8.1.8. Pump by Rate• 2.8.2.8.1. Delay Between Starts

This reduces power surge by not having the first pump start immediately upon power resumption. When this delay expires, other pumps will start as per 2.8.2.8.1. *Delay Between Starts*.

2.9. Discrete Inputs

Discrete inputs can be used for the following:

- Passing other information to a remote system through communications.
- Backup level override.

Use the parameters listed above to have discrete inputs modify the unit's operation. To configure the discrete input itself, use the following parameters:

2.9.1. Backup Level Override

Overrides the transducer reading by a discrete input, such as a contacting point device. The transducer reading will be fixed at the programmed override value until the discrete input is released.

The device makes decisions based on the override values.

2.9.1.1. Transducer Selector

Sets the transducer index for all parameters applicable to this sub-menu.

2.9.1.2. Discrete Input Number

Sets the discrete input to act as the source for a Level reading override.

Index	Transducer
Options	*No Override
	DI 1 Override Signal
	DI 2 Override Signal
Related	<ul style="list-style-type: none">• 2.9.1.3. Level Override Value

2.9.1.3. Level Override Value

This value is substituted for the current reading when the selected discrete input is enabled and activated.

Index	Transducer
Values	Range: 0.0 to 99.00 m or equivalent, depending on 2.1.1. Units
	Preset: 0.00
Alters	Current reading
Related	<ul style="list-style-type: none">• 2.1.3. Sensor Mode• 2.1.1. Units• 2.2.4. Empty• 2.2.2. Span• 2.9.1.2. Discrete Input Number

Notes:

- Enter value in current 2.1.1. Units.
- Valid for Level, Space, and Distance.
- Volume is calculated based on the Backup Level.

Example

Transducer 1 is configured for a Level measurement. Digital Input 2 is connected to a Hi Level Backup switch located a level of 4.3 m.

Parameter	Index	Value
2.9.1.2. Discrete Input Number	1	2
2.9.1.3. Level Override Value	1	4.3

When the level rises to 4.3 m, and the switch is activated, the reading is forced to 4.3 m. The reading stays at 4.3 m until the switch is deactivated.

2.9.1.4. Override Time Delay

Defines the time used to calm (debounce) the override condition input.

Index	Transducer
--------------	------------

Values	Range: 0.0 to 9999
	Preset: 5 seconds
Related	<ul style="list-style-type: none"> • 2.9.1.2. Discrete Input Number • 2.9.1.3. Level Override Value • 2.9.2.1. Discrete Input 1

Note: Activation of the Level Override is subject to the measurement cycle. This can add up to four seconds to the overall response time depending on operating conditions and programming.

2.9.2. Discrete Input Logic

2.9.2.1. Discrete Input 1

Changes the behavior of Discrete Input 1.

Options	Forced OFF
	Forced ON
	* Normally Open
	Normally Closed

2.9.2.2. Discrete Input 2

Changes the behavior of the Discrete Input 2.

Options	Forced OFF
	Forced ON
	* Normally Open
	Normally Closed

2.9.2.3. Discrete Input 1 Scaled State

Shows the current value of the discrete input after any scaling is applied. Read only.

Index	Discrete input
Modes	Active
	Inactive

Readings are updated continuously even in PROGRAM mode. The value signals a level override event.

2.9.2.4. Discrete Input 2 Scaled State

Shows the current value of the discrete input after any scaling is applied. Read only.

Index	Discrete input
Modes	Active
	Inactive

Readings are updated continuously even in PROGRAM mode. The value signals a level override event.

2.10. Other Control

Sets other relay control features.

2.10.1. External Totalizer

Tracks the volume of material that passes through a system. The external totalizer controls a relay to signal an external totalizing device. The relay toggles ON and OFF at a rate set by the parameters below.

2.10.1.1. Transducer Selector

Sets the transducer index for all parameters applicable to this sub-menu. The parameters will only affect the relays set to 2.8.1.4. Relay Function = Totalizer.

2.10.1.2. Multiplier

Use this feature if the remote totalizer (the device connected to the relay set to 2.8.1.4. Relay Function = Totalizer) updates too slowly or rapidly.

Index	Single-point model	Dual-point model
	Global	Transducer
Options	0.001	
	0.01	
	0.1	
	*1	
	10	
	100	
	1,000	
	10,000	
	100,000	
	1,000,000	
10,000,000		
Related	<ul style="list-style-type: none">• 2.1.3. Sensor Mode• 2.8.1.4. Relay Function• 2.8.2.4. Relay Interval Setpoint• 2.10.1.3. Relay Duration	

This parameter is relevant only if Operation is set to OCM or Pumped Volume (2.1.3. Sensor Mode = Flow rate in open channel or Pump Totalizer).

The relays on the HydroRanger have a maximum frequency of 2.5 Hz. Enter the factor (powers of 10 only) by which actual volume is divided, prior to Remote Totalizer count increment.

Example: For a Remote Totalizer update by 1000s of volume units, enter 3.

2.10.1.3. Relay Duration

Use this feature (if desired) to adjust the minimum contact closure duration of a relay set as a totalizer or flow sampler (2.8.1.4. Relay Function = Totalizer or Flow Sampler).

Index	Global
Values	Range: 0.1 to 1024 seconds
	Preset: 0.188 seconds
Related	2.8.1.4. Relay Function

Enter minimum contact closure duration (in seconds) required by the device connected.

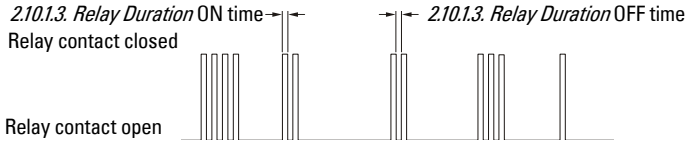

2.10.2. External Sampler

2.10.2.1. Transducer Selector

Sets the transducer index for all parameters applicable to this sub-menu.

2.10.2.2. Mantissa

Establishes the number of flow units required to increment the Flow Sampler (the device connected to the relay set to 2.8.1.4. Relay Function = Flow Sampler), in conjunction with 2.10.2.3. Exponent.

Index	Single-point model	Dual-point model
		Global
Values	Range: 0.001 to 9999	
	Preset: 1.000	
Related	<ul style="list-style-type: none"> • 2.1.3. Sensor Mode • 2.8.1.4. Relay Function • 2.13.2. Primary Measuring Device • 2.13.4.1. Flow Exponent • 2.13.5. PMD Dimensions • 2.13.4.2. Maximum Head • 2.13.4.3. Maximum Flow • 2.13.4.5. Zero Head • 2.13.4.4. Flow Time Units • 2.13.4.6. Flowrate Decimal • 2.13.6.1.1. Head 1 • 2.13.6.1.2. Flow 1 • 2.13.4.8. Low Flow Cutoff • 2.13.3. Auto Zero Head • 2.10.2.3. Exponent 	

This parameter is relevant only if Operation is set to OCM (2.1.3. Sensor Mode = Flow rate in open channel).

Enter the mantissa (Y) for the exponent (Z) in the formula:

Flow Sampler Increment = $Y \times 10^Z$ Flow units.

Example: To count once every 4310 (4.31×10^3) flow units: set 2.10.2.2. *Mantissa* to 4.31 and 2.10.2.3. *Exponent* to 3.

2.10.2.3. Exponent

Establishes the number of flow units required to increment the Flow Sampler (the device connected to the relay set to 2.8.1.4. Relay Function = Flow Sampler), in conjunction with 2.10.2.2. Mantissa.

Index	Single-point model	Dual-point model
		Global
Values	Range: -3 to +7 (integers only)	
	Preset: 0	
Related	<ul style="list-style-type: none"> • 2.1.3. Sensor Mode • 2.8.1.4. Relay Function • 2.13.2. Primary Measuring Device • 2.13.4.1. Flow Exponent • 2.13.5. PMD Dimensions • 2.13.4.2. Maximum Head • 2.13.4.3. Maximum Flow • 2.13.4.5. Zero Head • 2.13.4.4. Flow Time Units • 2.13.4.6. Flowrate Decimal • 2.13.6.1.1. Head 1 • 2.13.6.1.2. Flow 1 • 2.13.4.8. Low Flow Cutoff • 2.13.3. Auto Zero Head) • 2.10.2.2. Mantissa 	

This parameter is relevant only if Operation is set to OCM (2.1.3. *Sensor Mode = Flow rate in open channel*).

Enter the exponent (Z) for the mantissa (Y) in the formula:

Flow Sampler Increment = $Y \times 10^Z$ Flow units.

2.10.2.4. Relay Duration

Adjusts the minimum contact closure duration of a relay set as a flow sampler (2.8.1.4. Relay Function = Flow Sampler), if desired.

Index	Global
Values	Range: 0.1 to 1024
	Preset: 0.2 seconds
Related	2.8.1.4. Relay Function

Enter minimum contact closure duration (in seconds) required by the device connected.

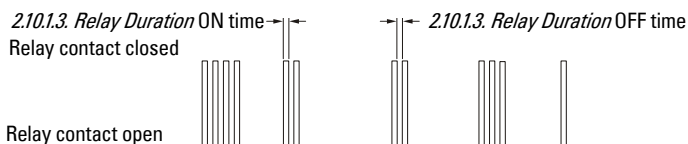

2.10.2.5. Relay Selector

Sets the relay index for all parameters applicable to this sub-menu.

2.10.2.6. Relay Interval Setpoint

Sets the length of time between starts, in hours.

Index	Relay
Values	Range: 0 to 9000 hours
	Preset: 0.000 hours
Altered by	2.8.1.3. <i>Preset Applications</i>
Related	2.8.1.4. <i>Relay Function</i>

2.10.3. Flush System

Controls an electrically operated flush valve on a pump to divert some pump output back into the wet well to stir up sediment.

Notes:

- If any of the following parameters are set to **0**, this feature will not work.
- In Dual-point mode, a flush valve can be set up for each of the three available level inputs (2.1.3. *Sensor Mode* = Dual-Point Difference or Dual-Point Average).

Single-point Mode

Enter the HydroRanger relay number of the pump with the flush valve. The activation of this pump relay drives the usage of the flush system. Both 2.10.3.3. *Flush Cycles* and 2.10.3.4. *Flush Interval* are based on the operation of this relay, and control any relay set to 2.8.1.4. *Relay Function* = Flush Valve.

Dual-point Mode

The indexed relay is the one that controls the flush device. The value is the pump relay that is watched by the flush system. Enter the pump relay value into the parameter at the flush relay index.

Example: If you need to watch pump Relay 1 to control a flush valve on Relay 2 (with Relay index 2 selected), set 2.10.3.2. *Flush Pump* = 1.

2.10.3.1. Relay Selector

Sets the relay index for all parameters applicable to this sub-menu. These parameters only affect relays set to 2.8.1.4. Relay Function = Flush Valve.

2.10.3.2. Flush Pump

Picks the number of the pump relay which triggers the flushing device.

Index	Single-point model	Dual-point model
		Global
Values	Range: 0 to 6	
	Preset: 0	
Related	2.8.1.4. <i>Relay Function</i> = Flush Valve	

Enter the HydroRanger relay number of the pump with the flush valve. The activation of this pump relay drives the usage of the flush system. Both 2.10.3.4. *Flush Interval* and 2.10.3.3. *Flush Cycles* are based on the

operation of this relay and controls any relay set to *2.8.1.4. Relay Function* = Flush Valve.

2.10.3.3. Flush Cycles

Sets the number of pump cycles requiring flush control.

Index	Single-point model	Dual-point model
	Global	Relay
Values	Range: 0 to 34464	
	Preset: 0	
Related	<i>2.8.1.4. Relay Function</i> = Flush Valve	

If three flush cycles are required after every ten pump cycles, then:

2.10.3.4. Flush Interval = 10

2.10.3.3. Flush Cycles = 3

2.10.3.4. Flush Interval

Sets the number of pump cycles before flush control is enabled.

Index	Single-point model	Dual-point model
	Global	Relay
Values	Range: 0 to 37856	
	Preset: 0	
Related	<i>2.8.1.4. Relay Function</i> = Flush Valve	

To start a new flush cycle every ten times the pumps are run, set this to 10.

2.10.3.5. Flush Duration

Sets the length of time for each flush cycle that the flush control is active.

Index	Single-point model	Dual-point model
	Global	Relay
Values	Range: 0.000 to 9999 seconds	
	Preset: 0.000 seconds	
Related	<i>2.8.1.4. Relay Function</i> = Flush Valve	

2.11. Signal Processing

2.11.1. Temperature and Velocity

2.11.1.1. Transducer Selector

Sets the transducer index for all parameters applicable to this sub-menu.

2.11.1.2. Sound Velocity

Enters the value adjusted based on parameter 2.11.1.7. Sound Velocity at 20°C vs. 2.11.1.3. Process Temperature characteristics of air.

Index	Single-point model	Dual-point model
	Global	Transducer
Values	Range: 50.3 to 20011.9 m/s (165 to 6601 ft/s)	
Related	<ul style="list-style-type: none">• 2.11.1.8. Auto Sound Velocity• 2.11.1.7. Sound Velocity at 20°C	

Alternatively, enter the current sound velocity (if known), or perform a 2.11.1.8. Auto Sound Velocity calibration. The units are in m/s if 2.1.1. Units = meters, centimeters, or millimeters; if 2.1.1. Units = feet or inches, then they are in ft/s).

2.11.1.3. Process Temperature

Displays the transducer temperature in °C.

Index	Transducer
Values	Range: -50 to 150 °C (Read only)
Altered by	2.11.1.4. Temperature Source
Related	<ul style="list-style-type: none">• 2.11.1.8. Auto Sound Velocity• 2.11.1.2. Sound Velocity• 2.11.1.7. Sound Velocity at 20°C• 2.11.1.6. Fixed Temperature

If 2.11.1.4. Temperature Source is set to any value other than Fixed Temperature, the value displayed is the temperature measured. If 2.11.1.4. Temperature Source is set to Fixed Temperature, the 2.11.1.6. Fixed Temperature value is displayed.

2.11.1.4. Temperature Source

Selects the source of the temperature reading used to adjust the speed of sound.

Index	Transducer
Options	*AUTO
	Fixed Temperature
	Transducer
	External TS-3
	Average of Sensors
Alters	2.11.1.3. Process Temperature
Related	<ul style="list-style-type: none">• 2.11.1.8. Auto Sound Velocity• 2.11.1.2. Sound Velocity• 2.11.1.7. Sound Velocity at 20°C• 2.11.1.6. Fixed Temperature

The HydroRanger uses the TS-3 temperature sensor assigned to the transducer. If one is not connected, the ultrasonic/temperature transducer is used. If the transducer does not have an internal temperature sensor, the 2.11.1.6. Fixed Temperature value is used.

If the acoustic beam atmosphere temperature varies with distance from the transducer, connect a TS-3 Temperature Sensor and ultrasonic/temperature transducers, and select **average**.

In gasses other than air, the temperature variation may not correspond with the speed of sound variation. In these cases, turn off the temperature sensor and use a fixed temperature.

2.11.1.5. Temperature Transducer Allocation

*This feature may only be used for **differential** or **average** Operation (2.1.3. Sensor Mode = Dual-Point Difference or Dual-Point Average).*

Index	Transducer
Options	*Transducer 1
	Transducer 2
	Transducer 1 and 2 average
Related	<ul style="list-style-type: none"> • 2.11.1.8. Auto Sound Velocity • 2.11.1.2. Sound Velocity • 2.11.1.7. Sound Velocity at 20°C

As preset, the temperature measurements of ultrasonic/temperature Transducer 1 and 2 are allocated to Points 1 and 2, respectively.

If there is a need to have the temperature measurements from both transducers to be identical while one device is located close to a radiant heat source, use this feature. Allocate the temperature measurement of the other transducer to both transducer Point Numbers.

Enter the number of the Transducer whose temperature measurement will be used for the distance calculation of the Point Number displayed. When both transducers are allocated to a Point Number, the temperature measurements from each are averaged.

2.11.1.6. Fixed Temperature

Sets a fixed temperature value if a temperature-sensing device is not used.

Index	Transducer
Values	Range: -199 to 200°C
	Preset: 20 °C
Related	<ul style="list-style-type: none"> • 2.11.1.8. Auto Sound Velocity • 2.11.1.2. Sound Velocity • 2.11.1.7. Sound Velocity at 20°C • 2.11.1.4. Temperature Source

Enter the temperature of the atmosphere within the transducer acoustic beam. If the temperature varies with distance from the transducer, enter the average temperature.

2.11.1.7. Sound Velocity at 20°C

This value is used to automatically calculate 2.11.1.2. Sound Velocity.

Index	Single-point model	Dual-point model
	Global	Transducer
Values	Range: 50.0 to 2000.0 m/s (164 to 6562 ft/s)	
	Preset: 344.1 m/s	
Related	<ul style="list-style-type: none">• 2.1.1. Units• 2.11.1.8. Auto Sound Velocity• 2.11.1.2. Sound Velocity	

Check this value to verify the acoustic beam atmosphere is **air** (344.1 m/s or 1129 ft/s) after performing a Sound Velocity Calibration (for the procedures, see *Using Sound Velocity Calibration* below) .

Alternatively, if the acoustic beam atmosphere Sound Velocity at 20°C (68 °F) is known, and the sound velocity vs. temperature characteristics are similar to that of **air**, enter the sound velocity. The units are in m/s if 2.1.1. Units = meters, centimeters, or millimeters; if 2.1.1. Units = feet or inches, then they are in ft/s).

2.11.1.8. Auto Sound Velocity

Changes the speed of sound constant.

Index	Single-point model	Dual-point model
	Global	Transducer
Values	Range: -999 to 9999	
Related	<ul style="list-style-type: none">• 2.11.1.2. Sound Velocity• 2.11.1.7. Sound Velocity at 20°C	

Conditions for use of this feature:

- The acoustic beam atmosphere is other than air.
- The acoustic beam atmosphere temperature is unknown.
- The Reading accuracy is acceptable at higher material levels only.

For best results, calibrate with the level at a known value near empty.

Using Sound Velocity Calibration

Ensure a steady level at some low value (2.11.1.2. Sound Velocity and 2.11.1.7. Sound Velocity at 20°C adjusted accordingly):

Step 1. Measure the actual reading (such as with a tape measure).

Step 2. Enter the actual value.

Repeat this procedure if the atmosphere type, concentration, or temperature conditions are different from when the last sound velocity calibration was performed.

Note: In gasses other than air, the temperature variation may not correspond with the speed of sound variation. Turn off temperature sensor and use a fixed temperature.

2.11.1.9. Offset Correction

The value altered when a sensor offset calibration is performed using 2.2.5. Sensor Offset.

Index	Single-point model	Dual-point model
	Global	Transducer
Values	Range: -999 to 999.0	
Related	2.2.5. Sensor Offset	

Alternatively, if the amount of offset correction required is known, enter the amount to be added to the reading before display.

2.11.2. Echo Select

2.11.2.1. Transducer Selector

Sets the transducer index for all parameters applicable to this sub-menu.

2.11.2.2. Algorithm

Selects the algorithm to generate the measured value from the profile.

Index	Single-point model	Dual-point model
	Global	Transducer
Options	ALF Area Largest First	
	A Echo Area	
	L Largest Echo	
	F First Echo	
	AL Area Largest	
	AF Area First	
	LF Largest First	
	*BLF Best F-L	
	BL Best L	
	BF Best F	
	TF True First Echo	
	Related	<ul style="list-style-type: none">• 2.11.2.5. Reform Echo• 2.11.2.6. Narrow Echo Filter• 2.11.2.7. Spike Filter• 2.11.2.9. Echo Marker• 3.2.9.2. Long Confidence

Use this to select the algorithm(s) the Sonic Intelligence® echo selection is based on. Use 3.2.9.2. Long Confidence on page 198 to determine which algorithm gives the highest confidence under all level conditions. If the wrong echo is processed, observe the echo processing displays and select an alternate algorithm using this parameter.

For details on echo determinations and suggested usage, see Appendix A: Technical reference - Algorithm on page 234.

2.11.2.3. Long Echo Threshold

Determines which echoes are evaluated by software.

Index	Single-point model	Dual-point model
	Global	Transducer
Values	Range: 0 to 99	
	Preset: 5	
Related	3.2.9.2. Long Confidence	

When 3.2.9.2. Long Confidence exceeds the Long Echo Threshold, the echo is evaluated by Sonic Intelligence® .

2.11.2.4. Short Echo Threshold

Determines which echoes are evaluated by software.

Index	Single-point model	Dual-point model
	Global	Transducer
Values	Range: 0 to 99	
	Preset: 10	
Related	3.2.9.2. Long Confidence	

When 3.2.9.2. Long Confidence exceeds the Short Echo Threshold, the echo is evaluated by Sonic Intelligence® .

2.11.2.5. Reform Echo

Smooths jagged peaks in the echo profile.

Index	Single-point model	Dual-point model
	Global	Transducer
Values	Preset: 0 (Larger values mean more smoothing. Nearest acceptable value is returned.)	
Related	<ul style="list-style-type: none">• 2.1.6. Material• 2.11.2.2. Algorithm• 2.11.2.7. Spike Filter• 2.11.2.6. Narrow Echo Filter• 2.11.2.9. Echo Marker	

Use this feature when monitoring solids (2.1.6. Material = Solid) if the reported Level fluctuates slightly, though the monitored surface is still. Enter the amount (in ms) of long shot Echo Profile smoothing required. When a value is keyed in, the nearest acceptable value is entered.

2.11.2.6. Narrow Echo Filter

Filters out echoes of a specific width.

Index	Single-point model	Dual-point model
	Global	Transducer
Values	Preset: 0 (= OFF); the nearest acceptable value is returned; Greater = Wider	
Related	<ul style="list-style-type: none">• 2.11.2.2. Algorithm• 2.11.2.7. Spike Filter• 2.11.2.5. Reform Echo• 2.11.2.9. Echo Marker	

Use this for transducer acoustic beam interference (e.g. ladder rungs). Enter the width of false echoes (in ms) to be removed from the long shot Echo Profile. When a value is keyed in, the nearest acceptable value is entered.

2.11.2.7. Spike Filter

Dampens spikes in the echo profile to reduce false readings.

Index	Single-point model	Dual-point model
	Global	Transducer
Options	OFF	
	*ON	
Related	<ul style="list-style-type: none"> • 2.11.2.2. Algorithm • 2.11.2.6. Narrow Echo Filter • 2.11.2.5. Reform Echo • 2.11.2.9. Echo Marker 	

Use 2.11.2.7. *Spike Filter* if interference spikes are on the long shot Echo Profile display.

2.11.2.8. Submergence Detection

Used when the transducer is expected to be submerged on occasion.

Index	Single-point model	Dual-point model
	Global	Transducer
Options	*OFF	
	ON	
Related	<ul style="list-style-type: none"> • 2.2.4. Empty • 2.4.5. Material Level • Relays 	

When a transducer with a submergence shield is submerged, the shield traps an air pocket that creates a special echo. The HydroRanger recognizes the echo and advances the reading to the highest level and operates displays and outputs accordingly. This feature is effective for when power is returned while the transducer is submerged.

2.11.2.9. Echo Marker

The point on the primary echo on which the measured value is based.

Index	Single-point model	Dual-point model
	Global	Transducer
Values	Range: 5 to 95%	
	Preset: 50%	
Related	<ul style="list-style-type: none"> • 2.11.2.2. Algorithm • 2.11.2.7. Spike Filter • 2.11.2.6. Narrow Echo Filter • 2.11.2.5. Reform Echo 	

Use this feature if the reported material level fluctuates slightly, due to a variable rise in the leading edge of the true echo on the Echo Profile.

Enter the value (in percent of echo height) to ensure the Echo Lock Window intersects the Echo Profile at the sharpest rising portion of the Echo Profile representing the true echo.

2.11.2.10. Short Shot Bias

Slants the echo evaluation in favor of the short shot echo when both short and long shots are evaluated (see 2.1.17. Shot/pulse Mode on page 127).

Index	Single-point model	Dual-point model
		Global
Values	Range: 0 to 100	
	Preset: 20	
Related	<ul style="list-style-type: none"> • 2.1.17. Shot/pulse Mode • 2.1.11. Number of Short Shots • 2.1.7. Short Shot Frequency • 2.1.10. Long Shot Duration • 2.11.2.11. Short Shot Floor • 2.11.2.12. Short Shot Range 	

2.11.2.11. Short Shot Floor

Enter the minimum echo strength, in dB above 1 μ V, derived from a short shot to be considered for evaluation.

Index	Single-point model	Dual-point model
		Global
Values	Range: 0 to 100	
	Preset: 50	
Related	<ul style="list-style-type: none"> • 2.1.11. Number of Short Shots • 2.1.7. Short Shot Frequency • 2.1.10. Long Shot Duration • 2.11.2.10. Short Shot Bias • 2.11.2.12. Short Shot Range 	

2.11.2.12. Short Shot Range

Enter the maximum distance in 2.1.1. Units to be measured using short shot echoes.

Index	Single-point model	Dual-point model
		Global
Values	Range: 0 to 10 m or equivalent, depending on 2.1.1. Units	
	Preset: 1.000	
Altered by	2.1.5. Transducer	
Related	<ul style="list-style-type: none"> • 2.1.11. Number of Short Shots • 2.1.7. Short Shot Frequency • 2.1.10. Long Shot Duration • 2.11.2.10. Short Shot Bias • 2.11.2.11. Short Shot Floor 	

This feature is automatically altered when 2.1.5. Transducer is altered.

2.11.3. TVT Setup

2.11.3.1. Transducer Selector

Sets the transducer index for all parameters applicable to this sub-menu.

2.11.3.2. Auto False Echo Suppression

Sets the HydroRanger to ignore false echoes, together with 2.11.3.3. Auto Suppression Range. Use 2.11.3.3. Auto Suppression Range to set the Auto TVT distance first.

Options	*OFF
	ON
	Learn

Notes:

- This function works best when the vessel is empty or nearly empty: use it only if there is a minimum distance of 2 meters from the transducer face to the material.
- Set 2.11.3.2 Auto False Echo Suppression and 2.11.3.3 Auto Suppression Range during start up, if possible.
- If the vessel contains an agitator, the agitator should be running.

If the HydroRanger displays a full level, or if the reading fluctuates between a false high level and a correct level, set 2.11.3.2 Auto False Echo Suppression to elevate the TVT in this region and to de-sensitize the receiver from any 'base noise' caused by internal transducer reflections, nozzle echoes, or other vessel false echoes. Set 2.11.3.3 Auto Suppression Range and then 2.11.3.2 Auto False Echo Suppression (detailed instructions follow 2.11.3.3 Auto Suppression Range).

Display before Auto False Echo Suppression

(or when 2.11.3.2 Auto False Echo Suppression = OFF)

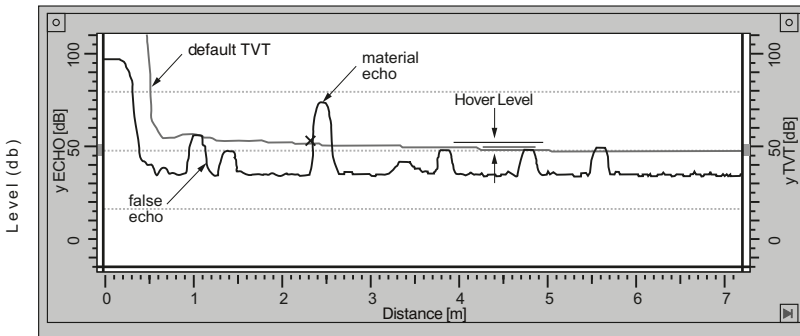

Distance (meters)

2.11.3.3. Auto Suppression Range

Defines the range of 2.11.3.2. Auto False Echo Suppression to use for ignoring false echoes. (See also 2.1.1. Units on page 122.)

Values	Range: 0.000 to 15 m (50 ft)
	Preset: 1.000 m (3.28 ft)

Determine the actual distance from the transducer face to the material surface. Subtract 0.5 m from this distance, and enter the result.

Set up (perform this function when vessel is empty or nearly empty):

- Step 1. Determine actual distance from transducer face to material level.
- Step 2. Enter the distance to material surface minus 0.5 m in to 2.11.3.3. Auto Suppression Range.
- Step 3. Select 2.11.3.2. Auto False Echo Suppression.
- Step 4. Select **Learn**. (2.11.3.2. Auto False Echo Suppression will revert to ON [use Learned TVT] automatically after a few seconds.)

Display after Auto False Echo Suppression

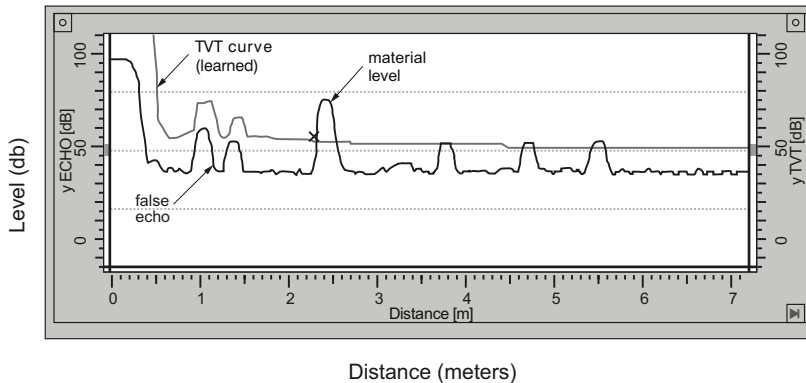

2.11.3.4. Hover Level

Defines (in percent) how high the TVT curve is placed above the profile, relative to the largest echo. When the HydroRanger is located in the center of the vessel, lower this parameter to prevent multiple echo detections.

Values	Range: 0 to 100%
	Preset: 33 %

2.11.3.5. Shaper Mode

Turns the TVT Shaper ON or OFF.

Index	Single-point model	Dual-point model
	Global	Transducer
Options	*OFF	
	ON	
Related	2.11.4. TVT Shaper	

Turn the TVT Shaper ON before using 2.11.4. TVT Shaper and afterwards. Turn the TVT Shaper ON and OFF while monitoring the effect to pick up the true echo.

2.11.3.6. TVT Type

Selects the TVT Curve used.

Index	Single-point model	Dual-point model
	Global	Transducer
Values	*Short Curved	
	Short Flat	
	Long Flat	
	Long Smooth Front	
	Long Smooth	
	Slopes	
Altered by	2.1.6. Material	
Related	<ul style="list-style-type: none">• 3.2.9.2. Long Confidence• 2.11.3.9. TVT Slope Minimum	

Select the TVT type which gives the highest 3.2.9.2. Long Confidence under all level conditions. Use this parameter with caution, and do not use TVT Slopes with the **BF Best F** or **BLF Best F-L** 2.11.2.2. Algorithm.

2.11.3.7. TVT dB

Adjusts the TVT Curve height to ignore false echoes (or pick up true echoes) near the start of the Echo Profile.

Index	Single-point model	Dual-point model
	Global	Transducer
Values	Range: -30 to 225	
	Preset: 50	
Related	<ul style="list-style-type: none">• 2.2.6. Blanking• 2.11.3.8. TVT ms	

Enter the minimum TVT Curve start point (in dB above 1 μ V RMS).

This feature should only be used if increased 2.2.6. Blanking would extend into the measurement range farther than desired .

2.11.3.8. TVT ms

Sets the device to ignore false echoes (or pick up true echoes) near the start of the Echo Profile, in conjunction with 2.11.3.7. TVT dB.

Index	Single-point model	Dual-point model
	Global	Transducer
Values	Range: 0 to 9999 milliseconds	
	Preset: 30 milliseconds	
Related	<ul style="list-style-type: none">• 2.11.3.7. TVT dB• 2.11.3.9. TVT Slope Minimum	

Enter the time (in ms) for the TVT Curve to decrease from the 2.11.3.7. TVT dB point to the TVT Curve baseline.

2.11.3.9. TVT Slope Minimum

Enters the minimum slope (in dB/s) for the middle of the TVT Curve.

Index	Single-point model	Dual-point model
	Global	Transducer
Values	Range: 0 to 9999 dB/s	
	Preset: 200 dB/s	
Related	<ul style="list-style-type: none">• 2.11.3.6. TVT Type• 2.11.3.8. TVT ms	

Use this feature to adjust the slope declination, and use it in conjunction with 2.11.3.8. TVT ms (when a Long Flat 2.11.3.6. TVT Type is selected) to ensure the TVT Curve remains above the false echoes in the middle of the Echo Profile. Alternatively, if 2.11.3.6. TVT Type = Slopes, preset is 2000.

2.11.4. TVT Shaper

Allows the manual adjustment of the TVT curve. Use this parameter in conjunction with SIMATIC PDM.

Index	Single-point model	Dual-point model
	Global	Transducer
Values	Range: -50 to 50	
	Preset: 0	
Related	2.11.3.5. Shaper Mode	

Use this feature to bias the shape of the TVT curve to avoid selecting false echoes from fixed objects.

Adjustment to this parameter is best done while viewing the echo profile with SIMATIC PDM.

The TVT curve is divided into 40 breakpoints, accessible by enabling the point number as the breakpoint index field. Each breakpoint is normalized to a value of 0, as displayed in the parameter value field. By changing the breakpoint value, up or down, the intensity of the bias applied to that breakpoint of the curve is respectively changed. By changing the value of adjacent breakpoints, the effective bias to the shaper can be broadened to suit the desired correction. In the case of multiple false echoes, shaping can be applied along

different points of the curve. Shaping should be applied sparingly in order to avoid missing the true echo.

2.11.4.1. Brkpt. 1-10

2.11.4.1.1. TVT Brkpt. 1

2.11.4.1.2. TVT Brkpt. 2

2.11.4.1.3. TVT Brkpt. 3

2.11.4.1.4. TVT Brkpt. 4

2.11.4.1.5. TVT Brkpt. 5

2.11.4.1.6. TVT Brkpt. 6

2.11.4.1.7. TVT Brkpt. 7

2.11.4.1.8. TVT Brkpt. 8

2.11.4.1.9. TVT Brkpt. 9

2.11.4.1.10. TVT Brkpt. 10

2.11.4.2. Brkpt. 11-20

2.11.4.2.1. TVT Brkpt. 11

2.11.4.2.2. TVT Brkpt. 12

2.11.4.2.3. TVT Brkpt. 13

2.11.4.2.4. TVT Brkpt. 14

2.11.4.2.5. TVT Brkpt. 15

2.11.4.2.6. TVT Brkpt. 16

2.11.4.2.7. TVT Brkpt. 17

2.11.4.2.8. TVT Brkpt. 18

2.11.4.2.9. TVT Brkpt. 19

2.11.4.2.10. TVT Brkpt. 20

2.11.4.3. Brkpt. 21-30

2.11.4.3.1. TVT Brkpt. 21

2.11.4.3.2. TVT Brkpt. 22

2.11.4.3.3. TVT Brkpt. 23

2.11.4.3.4. TVT Brkpt. 24

2.11.4.3.5. TVT Brkpt. 25

2.11.4.3.6. TVT Brkpt. 26

2.11.4.3.7. TVT Brkpt. 27

2.11.4.3.8. TVT Brkpt. 28

2.11.4.3.9. TVT Brkpt. 29

2.11.4.3.10. TVT Brkpt. 30

2.11.4.4. Brkpt. 31-40

2.11.4.4.1. TVT Brkpt. 31

2.11.4.4.2. TVT Brkpt. 32

2.11.4.4.3. TVT Brkpt. 33

2.11.4.4.4. TVT Brkpt. 34

- 2.11.4.4.5. TVT Brkpt. 35
- 2.11.4.4.6. TVT Brkpt. 36
- 2.11.4.4.7. TVT Brkpt. 37
- 2.11.4.4.8. TVT Brkpt. 38
- 2.11.4.4.9. TVT Brkpt. 39
- 2.11.4.4.10. TVT Brkpt. 40

2.11.5. Measurement Verification

2.11.5.1. Transducer Selector

Sets the transducer index for all parameters applicable to this sub-menu.

2.11.5.2. Up Sampling

Sets the number of consecutive echoes that must occur above the echo currently locked onto before the measurements are validated as the new reading (for 2.11.5.4. Echo Lock = Maximum verification or Material agitator).

Index	Single-point model	Dual-point model
		Global
Values	Range: 1 to 50	
	Preset: 5	
Related	<ul style="list-style-type: none"> • 2.11.5.4. Echo Lock • 2.11.5.3. Down Sampling 	

2.11.5.4. Echo Lock	Up Sampling value
Maximum verification	5
Material agitator	5

See 2.11.5.3. Down Sampling for more details.

2.11.5.3. Down Sampling

Sets the number of consecutive echoes that must occur below the echo currently locked onto before the measurements are validated as the new reading (for 2.11.5.4. Echo Lock = Maximum verification or Material agitator)

Index	Single-point model	Dual-point model
		Global
Values	Range: 1 to 50	
	Preset: 2	
Related	<ul style="list-style-type: none"> • 2.11.5.4. Echo Lock • 2.11.5.2. Up Sampling 	

2.11.5.4. Echo Lock	Down Sampling value
Maximum verification	5
Material agitator	2

Example setting:

- 2.11.5.4. *Echo Lock* = Material agitator
- 2.11.5.2. *Up Sampling* = 5
- 2.11.5.3. *Down Sampling* = 2

Result:

- Five consecutive measurements higher than the current reading will validate a new reading.

OR

- Two consecutive measurements lower than the current reading will validate a new reading.

Resetting 2.11.5.4. *Echo Lock* returns 2.11.5.2. *Up Sampling* and 2.11.5.3. *Down Sampling* to their respective preset values.

2.11.5.4. Echo Lock

Selects the measurement verification process.

Index	Single-point model	Dual-point model
		Global
Values	Lock OFF	
	Maximum verification	
	*Material agitator	
	Total lock	
Related	<ul style="list-style-type: none"> • 2.3.2. <i>Fill Rate/minute</i> • 2.3.3. <i>Empty Rate/minute</i> • 2.11.2.2. <i>Algorithm</i> • 2.11.5. <i>Measurement Verification</i> • 2.11.5.5. <i>Echo Lock Window</i> 	

If a material agitator (mixer) is used in the vessel monitored, set Echo Lock for **Maximum verification** or **Material agitator** to avoid agitator blade detection. Ensure the agitator is always ON while the HydroRanger is monitoring the vessel to avoid stationary blade detection.

When set for **Maximum verification** or **Material agitator**, a new measurement outside of the 2.11.5.5. *Echo Lock Window* must meet the criterion 2.11.5. *Measurement Verification* criterion.

For **Total lock**, 2.11.5.5. *Echo Lock Window* is preset to zero (0). The HydroRanger continuously searches for the best echo according to the 2.11.2.2. *Algorithm* chosen. If the selected echo is within the window, the window is then centered about the echo. If not, the window widens with each successive shot until the selected echo is within the window. The window then returns to its normal width.

When Echo Lock is OFF, the HydroRanger responds immediately to a new measurement as restricted by the 2.3.2. *Fill Rate/minute* and 2.3.3. *Empty Rate/minute*, however, measurement reliability is affected.

2.11.5.5. Echo Lock Window

Adjusts the size of the Echo Lock Window.

Index	Single-point model	Dual-point model
	Global	Transducer
Values	Range: 0.000 to 99.00 m or equivalent, depending on 2.1.1. Units; the nearest acceptable value is returned.	
	Preset: 0.000	
Altered by	2.3.4. Response Rate	
Related	<ul style="list-style-type: none">• 2.1.1. Units• 2.11.5.4. Echo Lock	

The Echo Lock Window is a **distance window** (2.1.1. Units) centered on the echo and used to derive the Reading. When a new measurement is in the window, it is re-centered and the new reading calculated. Otherwise, the new measurement is verified by 2.11.5.4. Echo Lock before the reading is updated.

When 0 is entered, the window is automatically calculated after each measurement. For slower 2.3.4. Response Rate values, the window is narrow; for faster 2.3.4. Response Rate values, the window becomes wider.

2.11.5.6. Fuzz Filter

Stabilizes the reported level, due to level fluctuations (such as a rippling or splashing liquid surface) within the 2.11.5.5. Echo Lock Window

Index	Single-point model	Dual-point model
	Global	Transducer
Values	Range: 0 to 100 (0 = OFF)	
Altered by	2.3.4. Response Rate	
Related	<ul style="list-style-type: none">• 2.2.2. Span• 2.11.5.5. Echo Lock Window	

This value (in % of 2.2.2. Span) is automatically altered when 2.3.4. Response Rate is changed. The higher the value entered, the greater the fluctuation stabilized.

2.12. Display

2.12.1. Local Display Backlight

Controls the LCD backlighting.

Index	Global
Options	OFF
	*ON
	Timed

The backlight can be forced ON or OFF, or be controlled by a programmer, in which case it will turn OFF five minutes after the last key is pressed.

2.12.2. LCD Contrast

Adjusts the luminance of the bright and dark colors of the display.

Options	Range: 0 (Low contrast) to 20 (High contrast)
	Preset: 10

The factory setting is for optimum visibility at room temperature and in average lighting conditions. Extremes of temperature will lessen the contrast. Adjust the value to improve visibility in different temperatures and lighting conditions.

2.12.3. Level Selector

Sets the Level Point index for all parameters applicable to this sub-menu.

2.12.4. Decimal Position

Defines the maximum number of decimal places used on the LCD.

Index	Level
Options	No digits
	1 digit
	*2 digits
	3 digits
Alters	2.13.4.6. Flowrate Decimal
Altered by	2.7.3. Maximum Volume
Related	3.2.6.2. Reading

In RUN mode, the decimal position adjusts to prevent the number of digits from exceeding the display capabilities. To keep the decimal place from shifting, reduce the number of decimal places to that shown at 100%.

Example: If 100% is 15 m, use two decimal places for sample readings of **15.00** or **12.15**.

2.12.5. Convert Reading

Multiplies the current value by the specified amount, to allow for scaling.

Index	Level
Values	Range: -999 to 9999
	Preset: 1.000
Related	3.2.6.2. Reading

Examples:

- If the measured value is in feet, enter **0.3333** to display the number of yards.
- For simple linear volume conversions, set *2.1.1. Units* to 1 (meter) and then enter the volume measurement per unit to get the correct

conversion. For example, if the reservoir contains 100 liters per vertical meter, use **100** to get the reading in liters.

Notes:

- This method does not calculate volume. It must not be used in place of the volume parameters if any volume dependent features (such as pump efficiency) are used. To calculate true volumes, see 2.7. *Volume* on page 140.
- Avoid entering a value that exceeds the display capabilities when multiplied by the maximum current reading. If value exceeds four digits, ##### is shown.

2.12.6. Offset Reading

Adds the specified value to the level reading, usually to reference the reading to sea level or another data level.

Index	Level
Values	Range: -999 to 9999
	Preset: 0.000
Related	3.2.6.2. <i>Reading</i>

The operation of the device is not affected by the Offset Reading. This value is used for display purposes only. All control measurements are still referenced to Empty.

2.12.7. Default Auxiliary Reading

Determines the parameter that displays in the Auxiliary Reading after powering up the device.

Index	Global
Options	*Totalizer
	Level
	Space
	Distance
	Volume
	Flow
	Head
	Temperature
	Rate
	Fail-safe remaining
	Confidence
	mA Output 1
	mA Output 2
	mA Input

2.12.8. Display Delay

Adjusts the time before the next Point reading is displayed.

Index	Global
Values	Range: 0.5 to 10
	Preset: 1.5 seconds
Related	2.1.3. Sensor Mode

Use this feature to adjust the delay before the display advances to the next Point reading. Display scrolling is independent from transducer scanning.

2.13. Flow

The calculated flowrate in 2.13.4.3. Maximum Flow units.

2.13.1. Transducer Selector

Sets the transducer index for all parameters applicable to this sub-menu. The parameters set will only apply if 2.1.3. Sensor Mode = Flow rate in open channel.

2.13.2. Primary Measuring Device

The type of primary measuring device (PMD) used.

Index	Single-point model	Dual-point model
	Global	Transducer
Options	* OFF	(no calculation)
	Exponential devices	(see 2.13.4.1. Flow Exponent)
	Palmer-Bowlus Flume	(see 2.13.5. PMD Dimensions)
	H-Flume	(see 2.13.5. PMD Dimensions)
	Universal Linear Flow Calculation	(see 2.13.6.1.1. Head 1 and 2.13.6.1.2. Flow 1)
	Universal Curved Flow Calculation	(see 2.13.6.1.1. Head 1 and 2.13.6.1.2. Flow 1)
	Rectangular Flume BS-3680	(see 2.13.5. PMD Dimensions)
	Thin Plate V-Notch Weir BS-3680	(see 2.13.5. PMD Dimensions)
Alters	<ul style="list-style-type: none"> • 2.13.4.1. Flow Exponent • 2.13.5. PMD Dimensions • 2.13.4.7. Flowrate Units 	
Altered by	2.1.3. Sensor Mode	
Related	<ul style="list-style-type: none"> • 2.13.4.2. Maximum Head • 2.13.4.3. Maximum Flow • 2.13.4.5. Zero Head • 2.13.6.1.1. Head 1 • 2.13.6.1.2. Flow 1 	

The HydroRanger is pre-programmed for common PMD flow calculations. If your PMD is not listed, select the appropriate Universal Flow Calculation.

Associated parameters 2.13.4.2. Maximum Head, 2.13.4.3. Maximum Flow, and 2.13.4.5. Zero Head may be scroll accessed. If 2.1.3. Sensor Mode = Flow rate in

open channel, this value is preset to 1. If 2.1.3. *Sensor Mode* is not set for OCM, it is preset to 0.

2.13.3. Auto Zero Head

Calibrates 2.13.4.5. Zero Head based on actual head measurements.

Index	Single-point model		Dual-point model	
	Global		Transducer	
Values	Range: -999 to 9999			
Related	<ul style="list-style-type: none"> • 2.2.4. <i>Empty</i> • 2.12.6. <i>Offset Reading</i> • 2.13.4.5. <i>Zero Head</i> • 2.11.1.3. <i>Process Temperature</i> 			

Use this parameter when the reported head is consistently high or low by a fixed amount.

Before using this feature, verify the following parameters are correct:

- 2.2.4. *Empty*
- 2.11.1.3. *Process Temperature*
- 2.12.6. *Offset Reading* = 0
- 2.13.4.5. *Zero Head*

The following is the procedure with “head” steady:

- Step 1. Measure the **actual** head (with a tape measure or solid rule).
- Step 2. Enter the **actual** head value.

The deviation between the entered 2.2.4. *Empty* value and the calibrated Empty value is stored in 2.11.1.9. *Offset Correction*. Alternatively, the 2.2.4. *Empty* can be corrected directly.

2.13.4. Basic Setup

2.13.4.1. Flow Exponent

Sets the exponent for the flow calculation formula.

Index	Single-point model		Dual-point model	
	Global		Transducer	
Values	Range: -999 to 9999			
	Preset: 1.55			
Altered by	2.13.2. <i>Primary Measuring Device</i>			
Related	<ul style="list-style-type: none"> • 2.13.4.2. <i>Maximum Head</i> • 2.13.4.3. <i>Maximum Flow</i> • 2.13.4.5. <i>Zero Head</i> 			

Use this parameter if the 2.13.2. *Primary Measuring Device* is set to Exponential devices. It creates an exponential curve with end points set by 2.13.4.2. *Maximum Head* and 2.13.4.3. *Maximum Flow* and with the curve based on the specified exponent.

Use the exponent specified by the PMD manufacturer, if available, or the sample value given below.

If 2.13.4.1. *Flow Exponent*= 1, the flow characteristic is a straight line

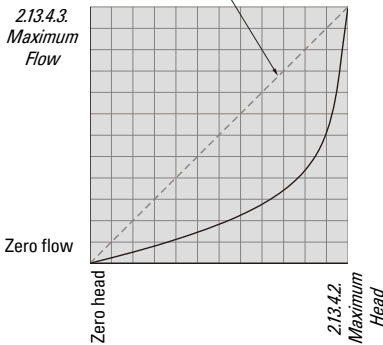

A word on exponents

The exponential equation is
 $Q = KH^{2.13.4.1. \text{ Flow Exponent}}$

Where:

Q = flow

K = internal constant

H = head

Example exponents

PMD Type	Exponent (sample only)
Suppressed Rectangular Weir	1.50
Cipolletti Weir	1.50
Venturi Flume	1.50
Parshall Flume	1.22 to 1.607
Leopold Lagco	1.547
V-Notch Weir	2.50

2.13.4.2. Maximum Head

Sets the level value associated with Maximum Flow, in 2.1.1. Units.

Index	Single-point model	Dual-point model
	Global	Transducer
Values	Range: -999 to 999999	
	Preset: 2.2.2. <i>Span</i> value	
Altered by	<ul style="list-style-type: none"> 2.1.1. <i>Units</i> 2.13.2. <i>Primary Measuring Device</i> 	
Related	<ul style="list-style-type: none"> 2.13.4.3. <i>Maximum Flow</i> 2.13.4.5. <i>Zero Head</i> 	

This represents the highest head level supported by the PMD and works in conjunction with 2.13.4.3. *Maximum Flow* to define the highest point in the exponential curve. Use it when the PMD requires a maximum head and flow reference point. This would include Exponential, Palmer-Bowlus Flume, H-Flume, and Universal breakpoints.

2.13.4.3. Maximum Flow

Sets the maximum flowrate associated with 2.13.4.2. Maximum Head.

Index	Single-point model	Dual-point model
	Global	Transducer

Values	Range: -999 to 9999
	Preset: 1000
Altered by	<i>2.13.2. Primary Measuring Device</i>
Related	<ul style="list-style-type: none"> • <i>2.13.4.2. Maximum Head</i> • <i>2.13.4.4. Flow Time Units</i> • <i>3.2.6.14. Flow</i>

This represents the flow at the highest head level supported by the PMD and works in conjunction with *2.13.4.2. Maximum Head* to define the highest point in the exponential curve. Use it when the PMD requires a maximum head and flow reference point. This would include Exponential, Palmer-Bowlus Flume, H-Flume, and Universal breakpoints.

Also, use this parameter with *2.13.4.4. Flow Time Units* to define the flowrate units.

Notes:

- The display of the measured value is limited to seven characters. A Maximum Flow value larger than seven characters will not display correctly.
- If measured value is larger than seven characters, the screen displays ###. A larger unit (*2.13.4.4. Flow Time Units*) should be used, or number of decimal points (*2.13.4.6. Flowrate Decimal*) should be reduced.

Example

Conditions	Enter
Flowrate display: millions of gallons/day , and maximum flowrate is 376,500,000 gallons/day .	376.5 for <i>2.13.4.3. Maximum Flow</i> , and Days for <i>2.13.4.4. Flow Time Units</i>

2.13.4.4. Flow Time Units

Defines the units used to display current flow and logging flow values.

Index	Single-point model	Dual-point model
		Global
Options	Seconds	
	Minutes	
	Hours	
	*Days	
Altered by	<i>2.13.4.7. Flowrate Units</i>	

This is used when the Primary Measuring Device is **Ratiometric** (*2.13.4.7. Flowrate Units*= Ratiometric).

Example

Conditions	Enter
Flowrate display: millions of gallons/day , and maximum flowrate is 376,500,000 gallons/day	376.5 for <i>2.13.4.3. Maximum Flow</i> , and Days for <i>2.13.4.4. Flow Time Units</i>

2.13.4.5. Zero Head

The distance above 2.2.4. Empty, in 2.1.1. Units representing zero head (and zero flow).

Index	Single-point model	Dual-point model
	Global	Transducer
Values	Range: -999 to 9999	
	Preset: 0.000	
Altered by	<ul style="list-style-type: none">• 2.1.1. Units• 2.2.2. Span	
Related	<ul style="list-style-type: none">• 2.2.4. Empty• 2.2.7. Range Extension• 3.2.6.13. Head	

This feature can be used for most weirs and some flumes (e.g. Palmer-Bowlus) where the zero reference is at a higher elevation than the channel bottom.

2.13.4.6. Flowrate Decimal

Sets the maximum number of decimal places to be displayed.

Index	Single-point model	Dual-point model
	Global	Transducer
Options	No digits	
	1 digit	
	*2 digits	
	3 digits	
Altered by	2.12.4. Decimal Position	

In RUN mode, the number of decimal places displayed is automatically adjusted (if necessary) to prevent the number of Flowrate digits from exceeding display capabilities.

The maximum number of head decimal places is controlled by 2.12.4. Decimal Position.

2.13.4.7. Flowrate Units

Defines the units used for flow calculations.

Note: Set this parameter only when using BS-3680/ISO 4359 Rectangular Flume or BS-3680/ISO 1438/1 Thin Plate V-Notch Weir (2.13.2. Primary Measuring Device = Rectangular Flume BS-36806 or Thin Plate V-Notch Weir BS-36807). Use the default option of Ratiometric calculation for 2.13.4.7. Flowrate Units when 2.13.2. Primary Measuring Device = Exponential devices, Palmer-Bowlus Flume, H-Flume, Universal Linear Flow Calculation, or Universal Curved Flow Calculation.

Index	Single-point model	Dual-point model
	Global	Transducer
Options	Ratiometric (2.13.2. Primary Measuring Device = all)	*Ratiometric calculation
	Absolute (2.13.2. Primary Measuring Device = Rectangular Flume BS-3680 or Thin Plate V-Notch Weir BS-3680 only)	L/S (Liters/second)
		M ³ /H (Cubic meters/hour)
		M ³ /D (Cubic meters/day)
		FT ³ /S (Cubic feet/second)
		IMPGAL/MIN (Gallons/minute – Imperial)
		MIMPGAL/D (Million gallons/day – Imperial)
		GAL/MIN (Gallons/minute – U.S.)
		MUSGAL/D (Million gallons/day – U.S.)
Alters	2.13.4.4. Flow Time Units	
Altered by	2.13.2. Primary Measuring Device	
Related	2.13.4.6. Flowrate Decimal	

2.13.4.8. Low Flow Cutoff

Eliminates totalizer activity for flows at, or below the cutoff value.

Index	Single-point model	Dual-point model
	Global	Transducer
Values	Range: 0.000 to 9999	
	Preset: 5.000 %, in equivalent units	
Altered by	2.1.1. Units	
Related	2.2.2. Span	

Use this to enter the minimum head in 2.1.1. Units.

2.13.5. PMD Dimensions

Sets the dimensions of the Primary Measuring Device (PMD).

Use this parameter if the 2.13.2. *Primary Measuring Device* is directly supported. The dimensions required for each PMD vary.

The following table is a reference to the parameters that must be set for each PMD.

Index	Single-point model	Dual-point model
	Global	Transducer and Dimension
Index values for supported PMDs	Dimension name (parameter menu reference)	
	Thin Plate V-Notch Weir	
	Notch angle (2.13.5.1. OCM Dimension 1)	
PMD selected	Discharge coefficient (2.13.5.2. OCM Dimension 2), Read only	
	Rectangular Flume BS-3680/ISO 4359	
	Approach width B (2.13.5.1. OCM Dimension 1)	
	Throat width b (2.13.5.2. OCM Dimension 2)	
	Hump height P (2.13.5.3. OCM Dimension 3)	
	Throat Length L (2.13.5.4. OCM Dimension 4)	
	Velocity coefficient (2.13.5.5. OCM Dimension 5), Read only	
	Discharge coefficient (2.13.5.6. OCM Dimension 6), Read only.	
	Cross sectional area (2.13.5.7. OCM Dimension 7). Read only.	
	Palmer-Bowlus	
	Flume width (2.13.5.1. OCM Dimension 1)	
	H-Flume	
	Flume height (2.13.5.1. OCM Dimension 1)	
Altered by	2.13.2. Primary Measuring Device	

2.13.5.1. OCM Dimension 1

2.13.5.2. OCM Dimension 2

2.13.5.3. OCM Dimension 3

2.13.5.4. OCM Dimension 4

2.13.5.5. OCM Dimension 5

2.13.5.6. OCM Dimension 6

2.13.5.7. OCM Dimension 7

2.13.6. Universal Head vs. Flow

2.13.6.1. Table 1-8

2.13.6.1.1. Head 1

Specifies the head breakpoints for which flowrate is known.

Index	Single-point model	Dual-point model
	Global	Transducer
Values	Range: 0.000 to 9999	
Related	2.13.6.1.2. Flow 1	

The values in the 2.2.2. *Span* for which flowrates are known. See *Universal calculation support* on page 107 for how to

specify universal flows.

2.13.6.1.2. Flow 1

Specifies the flowrate corresponding to each Head Breakpoint entered.

Index	Single-point model	Dual-point model
		Global
Values	Range: 0.000 to 9999	
Related	2.13.6.1.1. Head 1	

These are the flowrates for the related breakpoints. *Universal calculation support* on page 107 for how to specify universal flows.

Head vs. Flowrate

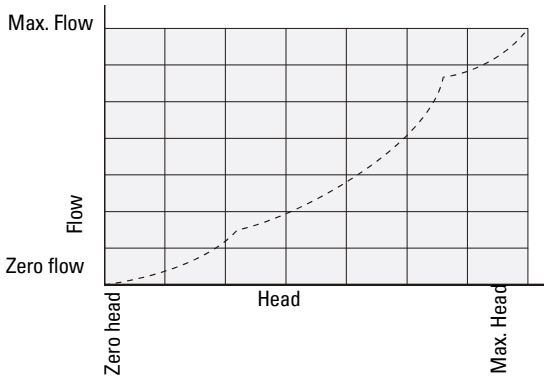

2.13.6.1.3. Head 2

2.13.6.1.4. Flow 2

2.13.6.1.5. Head 3

2.13.6.1.6. Flow 3

2.13.6.1.7. Head 4

2.13.6.1.8. Flow 4

2.13.6.1.9. Head 5

2.13.6.1.10. Flow 5

2.13.6.1.11. Head 6

2.13.6.1.12. Flow 6

2.13.6.1.13. Head 7

2.13.6.1.14. Flow 7

2.13.6.1.15. Head 8

2.13.6.1.16. Flow 8

2.13.6.2. Table 9-16

2.13.6.2.1. Head 9

2.13.6.2.2. Flow 9

2.13.6.2.3. Head 10

2.13.6.2.4. Flow 10

2.13.6.2.5. Head 11

2.13.6.2.6. Flow 11

2.13.6.2.7. Head 12

2.13.6.2.8. Flow 12

2.13.6.2.9. Head 13

2.13.6.2.10. Flow 13

2.13.6.2.11. Head 14

2.13.6.2.12. Flow 14

2.13.6.2.13. Head 15

2.13.6.2.14. Flow 15

2.13.6.2.15. Head 16

2.13.6.2.16. Flow 16

2.13.6.3. Table 17-24

2.13.6.3.1. Head 17

2.13.6.3.2. Flow 17

2.13.6.3.3. Head 18

2.13.6.3.4. Flow 18

2.13.6.3.5. Head 19

2.13.6.3.6. Flow 19

2.13.6.3.7. Head 20

2.13.6.3.8. Flow 20

2.13.6.3.9. Head 21

2.13.6.3.10. Flow 21

2.13.6.3.11. Head 22

2.13.6.3.12. Flow 22

2.13.6.3.13. Head 23

2.13.6.3.14. Flow 23

2.13.6.3.15. Head 24

2.13.6.3.16. Flow 24

2.13.6.4. Table 25-32

2.13.6.4.1. Head 25

2.13.6.4.2. Flow 25

2.13.6.4.3. Head 26

2.13.6.4.4. Flow 26

2.13.6.4.5. Head 27

2.13.6.4.6. Flow 27

2.13.6.4.7. Head 28

2.13.6.4.8. Flow 28

2.13.6.4.9. Head 29

- 2.13.6.4.10. Flow 29
- 2.13.6.4.11. Head 30
- 2.13.6.4.12. Flow 30
- 2.13.6.4.13. Head 31
- 2.13.6.4.14. Flow 31
- 2.13.6.4.15. Head 32
- 2.13.6.4.16. Flow 32

2.14. Totalizers

2.14.1. Transducer Selector

Sets the transducer index for all parameters applicable to this sub-menu.

Running Totalizers

Use these features to view, reset, or preset the eight-digit display totalizer when 2.1.3. *Sensor Mode* is set for **Flow rate in open channel** or **Pump Totalizer**. The eight-digit totalizer is divided into two groups of four digits. The four most significant totalizer digits are stored in 2.14.2. *Running Totalizer High*, and the four least significant digits are stored in 2.14.3. *Running Totalizer Low*. Adjust these values separately to set a new total.

Example

2.14.2. *Running Totalizer High* = 0017

2.14.3. *Running Totalizer Low* = 6.294

Totalizer Display = 00176.294

Totalizer units are dependent upon programming. Enter zero **0** (if required) to reset the totalizer to zero. Alternatively, enter any other (applicable) value, to preset the totalizer to the necessary value.

In RUN mode, the full totalizer value can be viewed in Measurement View 2 in Auxiliary Reading (see *The LCD Display* on page 25).

Note: A second point is available only if the dual-point feature is enabled.

2.14.2. Running Totalizer High

Shows and/or alters the four most significant digits of the totalizer value.

Index	Single Point Model		Dual Point Model
	Global		Transducer
Values	Range: 0.000 to 9999		
Related	<ul style="list-style-type: none"> • 2.14.3. <i>Running Totalizer Low</i> • 2.14.4. <i>Totalizer Decimal Position</i> • 2.14.5. <i>Totalizer Multiplier</i> 		

2.14.3. Running Totalizer Low

Shows and/or alters the four least significant digits of the totalizer value.

Primary Index	Single Point Model		Dual Point Model	
	Global		Transducer	
Values	Range: 0.000 to 9999			
Related	<ul style="list-style-type: none"> • 2.14.2. Running Totalizer High • 2.14.4. Totalizer Decimal Position • 2.14.5. Totalizer Multiplier 			

2.14.4. Totalizer Decimal Position

Sets the maximum number of decimal places to be displayed.

Index	Single-point model		Dual-point model	
	Global		Transducer	
Options	No digits			
	1 digit			
	*2 digits			
	3 digits			
Related	2.14.2. Running Totalizer High 2.14.3. Running Totalizer Low			

Note: Set the decimal position during initial commissioning of the HydroRanger 200 HMI. If the position is changed later, the totalizer data in 2.14.2. Running Totalizer High and 2.14.3. Running Totalizer Low will be incorrect and must be reset according to the new decimal value.

In RUN mode, the number of decimal places displayed is not automatically adjusted. When the LCD Total value is so large as to exceed display capabilities, the total **rolls over to 0** and continues incrementing.

2.14.5. Totalizer Multiplier

Use this feature if the LCD Total increments by too large (or too small) an amount.

Index	Single-point model		Dual-point model	
	Global		Transducer	
Options	0.001			
	0.01			
	0.1			
	*1			
	10			
	100			
	1,000			
	10,000			
	100,000			
	1,000,000			
	10,000,000			
Related	2.14.2. Running Totalizer High 2.14.3. Running Totalizer Low			

Enter the factor (powers of 10 only) by which actual volume is divided, prior to display on the LCD. Use a value such that the eight-digit totalizer doesn't roll over between readings.

Example: For an LCD Total display in 1000s of volume units, choose option 1,000.

3. Maintenance and Diagnostics

3.1. Identification

3.1.1. Tag

Sets the text to label the device. Limited to 32 alphanumeric characters. Appears at the top left corner of the display in Measurement mode (see The LCD Display on page 25).

3.1.2. Descriptor

Sets the text that can be used in any way. Limited to 32 ASCII characters. No specific recommended use.

3.1.3. Message

Sets the text that can be used in any way. Limited to 32 ASCII characters. No specific recommended use.

3.1.4. Order Number

3.1.5. Serial Number

Shows the unique factory-set serial number of the device. Read only.

3.1.6. Hardware Revision

Shows the electronics hardware of the device. Read only.

3.1.7. Firmware Revision

Shows the sensor firmware revision value. Read only.

3.1.8. Loader Revision

Shows the software revision value used to update the device. Read only.

3.1.9. Manufacture Date

Displays the manufacture date of this HydroRanger unit. Read only.

Index	Global
Values	Format: YY:MM:DD (Read only)
Related	3.2.2. Power-ON Resets

3.1.10. Date Last Configured

Shows the date when the device was last configured by SIMATIC PDM. Read only.

3.2. Diagnostics

3.2.1. Master Reset

Resets all parameters to original values.

Index	Single-point model	Dual-point model
	Global	Transducer
Options	*Do nothing	
	Factory defaults	

Use this feature prior to initial programming if arbitrary parameter values were used during a **bench test**, or after upgrading the software. Following a Master Reset, complete reprogramming is required.

When the factory default option is selected, the display will **pause** while reset is processed. When the display returns to the Diagnostics menu, the Master Reset is complete.

CAUTION: Be careful when using this feature. All data for all points will be reset. For convenience, be sure to record the values you want to re-enter.

3.2.2. Power-ON Resets

Displays the number of times power has been applied since 3.1.9. Manufacture Date.

Index	Global
Values	Range: 1 to 9999 (Read only)
Related	<ul style="list-style-type: none">• 3.1.9. Manufacture Date• 3.2.3. Power-ON Time

3.2.3. Power-ON Time

Displays the number of days this HydroRanger has been in operation.

Index	Global
Values	Range: 0.000 to 9999 (Read only)
Related	<ul style="list-style-type: none">• 3.1.9. Manufacture Date• 3.2.2. Power-ON Resets

The RUN Time value is updated once a day, and cannot be reset. However, in the event of a power interruption, the counter won't advance. Therefore, a unit that is powered down on a regular basis will not have an accurate value.

3.2.4. Relay Selector

Sets the relay index for all parameters applicable to this sub-menu.

3.2.5. Relay Logic Test

Forces the relay control logic into an activated or de-activated state.

Index	Relay
Options	*OFF
	Activate relay control
	De-activate relay control
Related	<ul style="list-style-type: none">• 2.8.1.4. Relay Function

This parameter tests site wiring and control logic programming. Forcing the relay to an **activated** or **de-activated** state is similar to the HydroRanger detecting an event and responding to it. Helpful in testing new installations and diagnosing control problems.

3.2.6. Measurement Values

3.2.6.1. Level Selector

Sets the Level Point index for all parameters applicable to this sub-menu.

3.2.6.2. Reading

Corresponds to the final reading after all programming is applied.

Index	Level
Values	Range: -999 to 9999

In general, this means that: *3.2.6.2. Reading = (Reading x 2.12.5. Convert Reading) + 2.12.6. Offset Reading.*

Reading Measurements by Operation

2.1.3. Sensor Mode	2.7.2. Vessel Shape = 0	2.7.2. Vessel Shape ≠ 0
OFF	---	---
Level	<i>3.2.6.3. Level</i>	<i>3.2.6.13. Head</i>
Space	<i>3.2.6.11. Space</i>	100% minus <i>3.2.6.13. Head</i>
Distance	<i>3.2.6.4. Distance (%)</i>	<i>3.2.6.4. Distance (%)</i>
Difference	<i>3.2.6.3. Level</i>	<i>3.2.6.3. Level</i>
Average	<i>3.2.6.3. Level</i>	<i>3.2.6.3. Level</i>
OCM	<i>3.2.6.14. Flow</i>	<i>3.2.6.14. Flow</i>
Pump Totalizer	<i>3.2.6.13. Head</i>	<i>3.2.6.13. Head</i>

3.2.6.3. Level

Shows the distance in 2.1.1. Units between 2.2.4. Empty and the monitored surface.

Index	Level
Values	Range: -999 to 9999 (Read only)
Related	<ul style="list-style-type: none"> • <i>2.1.1. Units</i> • <i>2.2.4. Empty</i> • <i>2.2.2. Span</i>

3.2.6.4. Distance (%)

Shows the distance between the surface and the transducer face (displays only as % of Empty).

Index	Transducer
Values	Range: 0.000 to 9999% (Displays as % of Empty; Read only)
Related	<ul style="list-style-type: none"> <i>2.1.1. Units</i> <i>2.2.4. Empty</i>

Use *3.2.6.12. Distance* unless the distance information is required in percent.

3.2.6.5. Volume

Shows the calculated volume of material.

Index	Level
Values	Range: 0.000 to 9999 (Read only)
Related	2.7.3. Maximum Volume

3.2.6.6. Rate

Shows the rate of material level change in 2.1.1. Units, per minute.

Index	Single Point Model	Dual Point Model
	Global	Transducer
Values	Range: -999 to 9999 (Read only)	
Altered By	2.3.5. Rate Filter	
Related	<ul style="list-style-type: none">• 2.1.1. Units• 2.2.2. Span	

A negative rate indicates the vessel is emptying.

3.2.6.7. Volume Rate

Shows the rate of change of volume in percent of maximum volume per minute.

Index	Single-point model	Dual-point model
	Global	Transducer
Values	Range: -999 to 9999 (Read only)	
Related	2.7.7. Inflow/discharge Adjust	

This value is used internally to calculate inflow in pumped volume applications (2.7.7. Inflow/discharge Adjust= Based on Rate Estimation).

3.2.6.8. Reading Maximum

Shows the highest reading calculated (in normal Reading units).

Index	Level
Values	Range: -999 to 9999 (Read only)
Related	3.2.6.9. Reading Minimum

To reset the values once the installation is working correctly, enter the value **0.0**.

3.2.6.9. Reading Minimum

Shows the lowest reading calculated (in normal Reading units).

Index	Level
Values	Range: -999 to 9999 (Read only)
Related	3.2.7. Pump Records

To reset the values once the installation is working correctly, enter the value **9999**.

3.2.6.10. Transducer Selector

Sets the transducer index for all parameters applicable to this sub-menu.

3.2.6.11. Space

Shows the distance between the monitored surface and 2.2.2. Span.

Index	Transducer
Values	Range: 0.000 to 9999 (Read only)
Related	2.2.2. Span

3.2.6.12. Distance

Shows the distance between the monitored surface and the transducer face.

Index	Transducer
Values	Range: 0.000 to 9999 (Read only)

3.2.6.13. Head

Shows the distance from 2.13.4.5. Zero Head to the monitored surface in 2.1.1. Units.

Index	Single-point model	Dual-point model
	Global	Transducer
Values	Range: 0.000 to 9999 (Read only)	
Related	2.1.1. Units 2.2.2. Span 2.13.4.5. Zero Head	

3.2.6.14. Flow

Shows the calculated flowrate in 2.13.4.3. Maximum Flow units.

Index	Single-point model	Dual-point model
	Global	Transducer
Values	Range: 0.000 to 9999 (Read only)	
Related	2.13.4.3. Maximum Flow	

3.2.6.15. Flow Maximum

Shows the highest flow rate calculated (in units).

Index	Single-point model	Dual-point model
	Global	Transducer
Values	Range: -999 to 9999 (Read only)	
Related	2.13.4.3. Maximum Flow	

3.2.6.16. Flow Minimum

Shows the lowest flow rate calculated (in units).

Index	Single-point model	Dual-point model
	Global	Transducer
Values	Range: -999 to 9999 (Read only)	
Related	2.13.4.3. Maximum Flow	

3.2.6.17. Transducer Temperature

Displays the temperature in °C (as monitored by the connected transducer).

Index	Transducer
Values	Range: -50 to 150

3.2.6.18. TS-3 Temperature

Displays the temperature in °C (as monitored by the TS-3 temperature sensor).

Index	Global
Values	Range: -50 to 150

3.2.6.19. mA Input

Displays the mA input value.

Index	mA Input
Values	Range: 0.000 to 24.00 mA

3.2.7. Pump Records

*Identifies pump usage and if the associated Relay Function (2.8.1.4. Relay Function) is set for any **pump control** feature. The value is that of the pump connected to the associated terminals.*

Enter a value to set the current record to that value. Use this if a pump is added with a known number of hours logged, or the value can be reset to **0** after maintenance.

3.2.7.1. Relay Selector

Sets the relay index for all parameters applicable to this sub-menu.

3.2.7.2. Pump Hours

Sets or shows the total running time of the selected relay, in hours.

Values	Range: 0 to 999999
---------------	--------------------

3.2.7.3. Pump Run Time

Sets or shows the total running time of the selected relay, in hours.

Values	Range: 0 to 999999
---------------	--------------------

3.2.7.4. Pump Starts

Shows or resets the accumulated number of times the selected relay has been ON.

Index	Relay
Values	Range: 0 to 9999
Related	2.8.1.4. Relay Function

To change the relay assignment, see 3.2.7.1. Relay Selector.

3.2.7.5. Pump Run-ONs

Shows or resets the accumulated number of times the selected relay has been held ON via 2.8.2.7.1. Run-ON Interval.

Index	Relay
Values	Range: 0 to 9999
Related	2.8.1.4. Relay Function

To change the relay assignment, see 3.2.7.1. Relay Selector.

3.2.8. Temperature Peak Values

The following features display the high and/or low temperatures in °C.

If the unit is powered up without a temperature sensor connected, the value – 50°C is displayed. This information can help trace problems with both built-in and external temperature sensors.

3.2.8.1. Transducer Selector

Sets the transducer index for all parameters applicable to this sub-menu.

3.2.8.2. Transducer Temperature Maximum

Shows the highest temperature encountered, as measured by the temperature sensor in the transducer (if applicable).

Index	Transducer
Values	Range: - 50 to 150°C (Read only)
	Preset: - 50°C
Related	3.2.8.3. Transducer Temperature Minimum

To reset the log after a short circuit on the transducer wiring, enter the value **-50**.

3.2.8.3. Transducer Temperature Minimum

Shows the lowest temperature encountered, as measured by the temperature sensor in the transducer (if applicable).

Index	Transducer
Values	Range: - 50 to 150°C (Read only)
	Preset: 150°C
Related	3.2.8.2. Transducer Temperature Maximum

To reset the log after an open circuit on the transducer wiring, enter the value **150**.

3.2.8.4. TS-3 Temperature Maximum

Shows the highest temperature encountered, as measured by the TS-3 temperature sensor (if applicable).

Index	Global
Values	Range: - 50 to 150°C (Read only)
	Preset: - 50°C
Related	3.2.8.5. TS-3 Temperature Minimum

To reset the log after a short circuit on the transducer wiring, enter the value **-50**.

3.2.8.5. TS-3 Temperature Minimum

Shows the lowest temperature encountered, as measured by the TS-3 Temperature Sensor (if applicable).

Index	Global
Values	Range: - 50 to 150°C (Read only)
	Preset: 150°C
Related	3.2.8.4. TS-3 Temperature Maximum

To reset the log after an open circuit on the transducer wiring, enter the value **150**.

3.2.9. Echo Quality

3.2.9.1. Transducer Selector

Sets the transducer index for all parameters applicable to this sub-menu.

3.2.9.2. Long Confidence

Displays the Long Echo Confidence of the measurement echo from the last shot.

Index	Transducer
Values	Range: 0 to 99
Related	<ul style="list-style-type: none">• 2.11.2.3. Long Echo Threshold• 2.11.3.6. TVT Type

Use this feature to monitor the effect of transducer aiming, location, and mechanical transducer/mounting isolation.

3.2.9.3. Short Confidence

Displays the Short Echo Confidence of the measurement echo from the last shot.

Index	Transducer
Values	Range: 0 to 99
Related	<ul style="list-style-type: none">• 2.11.2.3. Long Echo Threshold• 2.11.3.6. TVT Type

Use this feature to monitor the effect of transducer aiming, location, and mechanical transducer/mounting isolation.

3.2.9.4. Echo Strength

Displays the strength (in dB above 1 μ V RMS) of the echo which was selected as the measurement echo.

Index	Transducer
Values	Range: 0 to 99 (Read only)

3.2.9.5. Noise Average

Displays the average ambient noise (in dB above 1 μ V RMS) of a noise profile after each measurement.

The noise level is a combination of transient acoustic noise and electrical noise (induced into the transducer cable or receiving circuitry). See *Noise problems* on page 221.

3.2.9.6. Noise Peak

Displays the peak ambient noise (in dB above 1 μ V RMS) of a noise profile after each measurement.

3.2.9.7. Echo Time Filtered

Displays the time, in ms, from the transmission of the pulse, to when it is processed.

Index	Transducer
Values	Range: 0.0 to 9999 milliseconds (Read only)
Related	3.2.9.8. Echo Time Raw

3.2.9.8. Echo Time Raw

Displays the time, in ms, from the transmit pulse to the processed echo.

Index	Transducer
Values	Range: 0.0 to 9999 milliseconds (Read only)
Related	3.2.9.7. Echo Time Filtered

3.2.10. SmartLinX[®] Diagnostics

Note: These parameters are used to test and debug the SmartLinX[®] card (if installed). Disregard these parameters if you do not have a SmartLinX[®] card installed.

3.2.10.1. Hardware Status

Shows the results of ongoing hardware tests in the communications circuitry.

Index	Global	
Values	*Pass	No errors
	Fail	Error occurred communicating with card; communications should resume.
	Err1	No module installed, or module not supported; SmartLinX [®] communications have been disabled
Related	<ul style="list-style-type: none"> 3.2.10.2. Hardware Status Code 3.2.10.3. Hardware Error Count 	

If **Fail** or **Err1** is displayed in 3.2.10.1. *Hardware Status*, go to 3.2.10.2. *Hardware Status Code* and 3.2.10.3. *Hardware Error Count* for information about the error.

3.2.10.2. Hardware Status Code

*Indicates the precise cause of **Fail** or **Err1** condition from 3.2.10.1. *Hardware Status*.*

Index	Global	
--------------	--------	--

Values	*	No error
	8	No SmartLinx [®] card installed
	Any other value	Error code; provide this code to your Siemens representative for troubleshooting
Related	3.2.10.1. Hardware Status	

3.2.10.3. Hardware Error Count

*Shows the count that increments by 1 each time **Fail** is reported in 3.2.10.1. Hardware Status.*

Index	Global
Values	Range: 0 to 9999
	Error count; provide this number to your Siemens representative for troubleshooting.
Related	3.2.10.1. Hardware Status

3.2.10.4. Smartlinx[®] Module Type

Identifies the module type when SmartLinx[®] is used. If you are not using SmartLinx[®], this parameter is not functional. Please see the associated SmartLinx[®] instruction manual for a full description of this parameter.

3.2.10.5. Smartlinx[®] Protocol

Identifies the protocol when SmartLinx[®] is used. If you are not using SmartLinx[®], this parameter is not functional. Please see the associated SmartLinx[®] instruction manual for a full description of this parameter.

3.3. Simulation

Tests the application.

3.3.1. Discrete Inputs

3.3.1.1. Discrete Input 1

Sets how Discrete Input 1 signals are interpreted by the HydroRanger.

Index	Discrete Input (DI)
Options	Forced OFF
	Forced ON
	*Normally Open
	Normally Closed
Related	2.9.1.2. Discrete Input Number 2.9.1.3. Level Override Value

3.3.1.2. Discrete Input 2

Sets how Discrete Input 2 signals are interpreted by the HydroRanger.

Index	Discrete Input (DI)
--------------	---------------------

Options	Forced OFF
	Forced ON
	*Normally Open
	Normally Closed
Related	2.9.1.2. <i>Discrete Input Number</i> 2.9.1.3. <i>Level Override Value</i>

3.3.1.3. Discrete Input 1 Scaled State

Shows the current value of the discrete input after any scaling is applied. Read only.

Index	Discrete input
Modes	Active
	Inactive

Readings are updated continuously even in PROGRAM mode. The value signals a level override event.

3.3.1.4. Discrete Input 2 Scaled State

Shows the current value of the discrete input after any scaling is applied. Read only.

Index	Discrete input
Modes	Active
	Inactive

Readings are updated continuously even in PROGRAM mode. The value signals a level override event.

4. Communication

The HydroRanger communications ports are configured by a series of parameters that are indexed by port. See *Appendix C: Communications* on page 246 for a complete description of the communications set-up.

Unless otherwise noted, communication parameters are indexed to the following communications ports:

Port	Description
1	RS-232 port (RJ-11 modular telephone)
2	RS 485 port on terminal block

4.1. Communications Port Selector

Sets the communications port index for all parameters applicable to this sub-menu.

Options	*Communications Port 1
	Communications Port 2

4.2. Device Address

Sets the unique identifier of the HydroRanger on the network.

Index	Communications Port
Options	Range: 0 to 9999

For devices connected with the Siemens protocol, this parameter is ignored. For devices connected with a serial Modbus slave protocol, this parameter is a number from 1-247. The network administrator must ensure that all devices on the network

have unique addresses. Do not use the value **0** for Modbus communications as this is the broadcast address and is inappropriate for a slave device.

4.3. Communications Timeout

Sets the maximum time allowed between receiving a request and transmitting the response.

Index	Communications Port
Values	Range: 0 to 60 000 milliseconds
	Preset: 5 000 milliseconds

If the maximum time is exceeded, no response will be transmitted, and the action required may not be completed.

4.4. Protocol

Sets the communications protocol used between the HydroRanger and other devices.

Index	Communications Port
Options	Communications Port disabled
	Dolphin protocol
	Modbus ASCII slave serial
	*Modbus RTU slave serial

The HydroRanger supports the internationally recognized Modbus standard in both ASCII and RTU formats. Other protocols are available with optional SmartLinux® cards.

4.5. Serial Baud Rate

Sets the communication rate with the master device.

Index	Communications Port
Values	4.8 kbaud
	9.6 kbaud
	*19.2 kbaud (preset for Port 2)
	*115.2 kbaud (preset for Port 1)

This specifies the rate of communication in kbaud. Any value may be entered but only the values shown above are supported. The baud rate should reflect the speed of the connected hardware and protocol used.

4.6. Parity

Sets the serial port parity.

Index	Communications Port
Options	*No parity
	Odd parity
	Even parity

Ensure that the communications parameters are identical between the HydroRanger and all connected devices. For example, many modems default to N-8-1 which is **No parity, 8 Data Bits, and 1 Stop Bit**.

4.7. Data Bits

Sets the number of data bits per character.

Index	Communications Port
Values	Range: 5 to 8

4.8. Stop Bits

Sets the number of bits between the data bits.

Index	Communications Port
Values	Range: 1 to 2
	Preset: 1

4.9. Modem Available

Sets the HydroRanger to use an external modem.

Index	Communications Port
Options	*No modem connected
	Answer only

4.10. Modem Inactivity Timeout

Sets the time that the device will keep the modem connected with no activity.

Index	Communications Port
Values/Options	Range: 0 to 9999 seconds
	Preset: 0 (No timeout)
Related	<ul style="list-style-type: none">• 4.9. Modem Available• 4.10. Modem Inactivity Timeout

To use this parameter, ensure that *4.9. Modem Available* = **Answer only**. Ensure that the value is low enough to avoid unnecessary delays when an unexpected disconnect occurs but long enough to avoid timeout while you are still legitimately connected. This parameter value is ignored by the Modbus Master Drivers, as they automatically disconnect when done.

Hanging up

If the line is idle and the *4.10. Modem Inactivity Timeout* expires, then the modem is directed to hang up the line. Ensure that *4.10. Modem Inactivity Timeout* is set longer than the standard polling time of the connected master device. **0** disables the inactivity timer, meaning there is no timeout.

4.11. Parameter Index Location

Determines where index information is stored for the parameter access area.

Index	Global
Options	*Global
	Parameter-specific
Altered by	4.4. Protocol

Global

The primary and secondary index values are global (they affect all of the parameter access area at once) and stored in:

- Primary index – R43,999
- Secondary index – R43,998

Parameter-specific

The primary and secondary index values are encoded into the format words found between R46,000 and R46,999. Each format word corresponds with the R44,000 series number in the parameter access map. For example, the format register R46,111 corresponds to the parameter *2.8.1.4. Relay Function* and the value is stored in R44,111. If the Modbus protocol (*4.4. Protocol*= [Modbus ASCII slave serial] or [Modbus RTU slave serial]) is not used, this parameter is ignored.

4.12. SmartLinX[®] reserved parameters (4.12.1. to 4.12.5.)

These are reserved for optional SmartLinX[®] communications cards and vary by card. Refer to the SmartLinX[®] documentation (A5E36197302) to determine if any of them are used.

5. Security

5.1. Write Protection

Sets the password to prevent any changes to parameters via local push buttons or Windows-based web browser. Write protection must match 5.2. User PIN for the device to be unlocked.

Values/Options	Range: -32768 to 32767	
	Unlock value: 1954	Lock OFF
	Any other value	Lock ON

- To turn Lock ON, key in any value other than the Unlock Value.
- To turn Lock OFF, key in the Unlock Value (1954).

5.2. User PIN

Sets the private password to prevent any changes to the parameters via local push buttons or remote communications.

Values	Range: 0 to 65535
	Preset: 1954

Notes:

- To view or change the User PIN, *5.1. Write Protection* must match the current User PIN value. If the PIN does not match, the screen displays '*****'
- If '*****' is displayed, the HydroRanger parameters cannot be changed and shows the lock icon, except for *5.1. Write Protection*.
- User PIN cannot be changed via communications.



WARNING: The User PIN value cannot be recovered in the field. Record a new User PIN in a secure manner.

5.3. Protocol Selector

Sets the protocol index for all parameters applicable to this sub-menu.

5.4. Communications Control

Enables the read/write access to parameters via remote communications.

Note: This parameter controls the lock access via communications.

Index	Protocol (Index 1 controls the Modbus Master (RS-485 or RS-232); Index 2 controls the Fieldbus Master (PROFIBUS DP, DeviceNet, or Allen Bradley Remote I/O))
Values	Read only
	*Read/Write
	Restricted access (Read only, except for <i>5.4. Communications Control</i> , which is Read/Write.)

6. Language

Options	*ENGLISH
	DEUTSCH
	FRANCAIS
	ESPANOL
	简体中文
	ITALIANO
	PORTUGUES
	русский

Alphabetical list

Parameter name (number), page

0/4 mA Level Value (2.6.2.), p 139
20 mA Level Value (2.6.3.), p 139
20 mA Output Trim (2.5.12.), p 138
20 mA Setpoint (2.5.6.), p 137
4 mA Output Trim (2.5.11.), p 138
4 mA Setpoint (2.5.5.), p 137
Algorithm (2.11.2.2.), p 166
Auto False Echo Suppression (2.11.3.2.), p 170
Auto Sound Velocity (2.11.1.8.), p 165
Auto Suppression Range (2.11.3.3.), p 171
Auto Zero Head (2.13.3.), p 181
Backup Level Override (2.9.1.), p 155
Basic Setup (2.13.4.), p 181
Basic Setup (2.8.1.), p 145
Blanking (2.2.6.), p 129
Brkpt. 1-10 (2.11.4.1.), p 174
Brkpt. 11-20 (2.11.4.2.), p 174
Brkpt. 21-30 (2.11.4.3.), p 174
Brkpt. 31-40 (2.11.4.4.), p 174
Calibration (2.2.), p 127
Calibration (2.2.), p 127
Communication (4.), p 201
Communications Control (5.4.), p 205
Communications Port Selector (4.1.), p 201
Communications Timeout (4.3.), p 202
Convert Reading (2.12.5.), p 178
Current Input (2.6.), p 139
Current Output (2.5.), p 135
Current Output Function (2.5.3.), p 136
Data Bits (4.7.), p 203
Date Last Configured (3.1.10.), p 191
Decimal Position (2.12.4.), p 178
Default Auxiliary Reading (2.12.7.), p 179
Delay Between Starts (2.8.2.8.1.), p 155
Descriptor (3.1.2.), p 191
Device Address (4.2.), p 201
Diagnostics (3.2.), p 192
Dimension A (2.7.4.), p 142
Dimension L (2.7.5.), p 143
Discrete Input 1 (2.9.2.1.), p 157
Discrete Input 1 Scaled State (2.9.2.3.), p 157
Discrete Input 1 Scaled State (2.9.2.3.), p 157
Discrete Input 2 (2.9.2.2.), p 157
Discrete Input 2 (2.9.2.2.), p 157
Discrete Input 2 Scaled State (3.3.1.4.), p 201
Discrete Input Logic (2.9.2.), p 157
Discrete Input Logic (2.9.2.), p 157
Discrete Input Number (2.9.1.2.), p 156
Discrete Inputs (2.9.), p 155
Discrete Inputs (3.3.1.), p 200
Display (2.12.), p 177
Display Delay (2.12.8.), p 180
Distance (%) (3.2.6.4.), p 193
Distance (3.2.6.12.), p 195
Down Sampling (2.11.5.3.), p 175

Parameter name (number), page

Echo Lock (2.11.5.4.),	p 176
Echo Lock Window (2.11.5.5.),	p 177
Echo Marker (2.11.2.9.),	p 168
Echo Quality (3.2.9.),	p 198
Echo Select (2.11.2.),	p 166
Echo Strength (3.2.9.4.),	p 198
Echo Time Filtered (3.2.9.7.),	p 199
Echo Time Raw (3.2.9.8.),	p 199
Empty (2.2.4.),	p 128
Empty Rate/minute (2.3.3.),	p 130
Emptying Indicator (2.3.10.),	p 133
Emptying Indicator (2.8.1.10.),	p 150
Exponent (2.10.2.3.),	p 160
External Sampler (2.10.2.),	p 159
External Totalizer (2.10.1.),	p 158
Fail-safe (2.4.),	p 133
Fail-safe Advance (2.4.6.),	p 135
Fail-safe Mode (2.4.4.),	p 134
Fail-safe Mode (2.5.10.),	p 138
Fill Rate/minute (2.3.2.),	p 130
Filling Indicator (2.3.9.),	p 132
Filling Indicator (2.8.1.9.),	p 149
Firmware Revision (3.1.7.),	p 191
Fixed Temperature (2.11.1.6.),	p 164
Flow (2.13.),	p 180
Flow (3.2.6.14.),	p 195
Flow 1 (2.13.6.1.2.),	p 187
Flow 10 (2.13.6.2.4.),	p 188
Flow 11 (2.13.6.2.6.),	p 188
Flow 12 (2.13.6.2.8.),	p 188
Flow 13 (2.13.6.2.10.),	p 188
Flow 14 (2.13.6.2.12.),	p 188
Flow 15 (2.13.6.2.14.),	p 188
Flow 16 (2.13.6.2.16.),	p 188
Flow 17 (2.13.6.3.2.),	p 188
Flow 18 (2.13.6.3.4.),	p 188
Flow 19 (2.13.6.3.6.),	p 188
Flow 2 (2.13.6.1.4.),	p 187
Flow 20 (2.13.6.3.8.),	p 188
Flow 21 (2.13.6.3.10.),	p 188
Flow 22 (2.13.6.3.12.),	p 188
Flow 23 (2.13.6.3.14.),	p 188
Flow 24 (2.13.6.3.16.),	p 188
Flow 25 (2.13.6.4.2.),	p 188
Flow 26 (2.13.6.4.4.),	p 188
Flow 27 (2.13.6.4.6.),	p 188
Flow 28 (2.13.6.4.8.),	p 188
Flow 29 (2.13.6.4.10.),	p 189
Flow 3 (2.13.6.1.6.),	p 187
Flow 30 (2.13.6.4.12.),	p 189
Flow 31 (2.13.6.4.14.),	p 189
Flow 32 (2.13.6.4.16.),	p 189
Flow 4 (2.13.6.1.8.),	p 187
Flow 5 (2.13.6.1.10.),	p 187
Flow 6 (2.13.6.1.12.),	p 187
Flow 7 (2.13.6.1.14.),	p 187
Flow 8 (2.13.6.1.16.),	p 187

Parameter name (number), page

Flow 9 (2.13.6.2.2.),	p 187
Flow Exponent (2.13.4.1.),	p 181
Flow Maximum (3.2.6.15.),	p 195
Flow Minimum (3.2.6.16.),	p 195
Flow Time Units (2.13.4.4.),	p 183
Flowrate Decimal (2.13.4.6.),	p 184
Flowrate Units (2.13.4.7.),	p 184
Flush Cycles (2.10.3.3.),	p 162
Flush Duration (2.10.3.5.),	p 162
Flush Interval (2.10.3.4.),	p 162
Flush Pump (2.10.3.2.),	p 161
Flush System (2.10.3.),	p 161
Fuzz Filter (2.11.5.6.),	p 177
Hardware Error Count (3.2.10.3.),	p 200
Hardware Revision (3.1.6.),	p 191
Hardware Status (3.2.10.1.),	p 199
Hardware Status Code (3.2.10.2.),	p 199
Head (3.2.6.13.),	p 195
Head 1 (2.13.6.1.1.),	p 186
Head 10 (2.13.6.2.3.),	p 187
Head 11 (2.13.6.2.5.),	p 188
Head 12 (2.13.6.2.7.),	p 188
Head 13 (2.13.6.2.9.),	p 188
Head 14 (2.13.6.2.11.),	p 188
Head 15 (2.13.6.2.13.),	p 188
Head 16 (2.13.6.2.15.),	p 188
Head 17 (2.13.6.3.1.),	p 188
Head 18 (2.13.6.3.3.),	p 188
Head 19 (2.13.6.3.5.),	p 188
Head 2 (2.13.6.1.3.),	p 187
Head 20 (2.13.6.3.7.),	p 188
Head 21 (2.13.6.3.9.),	p 188
Head 22 (2.13.6.3.11.),	p 188
Head 23 (2.13.6.3.13.),	p 188
Head 24 (2.13.6.3.15.),	p 188
Head 25 (2.13.6.4.1.),	p 188
Head 26 (2.13.6.4.3.),	p 188
Head 27 (2.13.6.4.5.),	p 188
Head 28 (2.13.6.4.7.),	p 188
Head 29 (2.13.6.4.9.),	p 188
Head 3 (2.13.6.1.5.),	p 187
Head 30 (2.13.6.4.11.),	p 189
Head 31 (2.13.6.4.13.),	p 189
Head 32 (2.13.6.4.15.),	p 189
Head 4 (2.13.6.1.7.),	p 187
Head 5 (2.13.6.1.9.),	p 187
Head 6 (2.13.6.1.11.),	p 187
Head 7 (2.13.6.1.13.),	p 187
Head 8 (2.13.6.1.15.),	p 187
Head 9 (2.13.6.2.1.),	p 187
Hover Level (2.11.3.4.),	p 171
Identification (3.1.),	p 191
Inflow/discharge Adjust (2.7.7.),	p 143
Language (6.),	p 205
LCD Contrast (2.12.2.),	p 178
Level (3.2.6.3.),	p 193
Level 1 (2.7.8.1.),	p 143

Parameter name (number), page

Level 10 (2.7.9.3.), p 144
Level 11 (2.7.9.5.), p 144
Level 12 (2.7.9.7.), p 144
Level 13 (2.7.9.9.), p 144
Level 14 (2.7.9.11.), p 144
Level 15 (2.7.9.13.), p 144
Level 16 (2.7.9.15.), p 144
Level 17 (2.7.10.1.), p 144
Level 18 (2.7.10.3.), p 144
Level 19 (2.7.10.5.), p 144
Level 2 (2.7.8.3.), p 143
Level 20 (2.7.10.7.), p 144
Level 21 (2.7.10.9.), p 144
Level 22 (2.7.10.11.), p 144
Level 23 (2.7.10.13.), p 144
Level 24 (2.7.10.15.), p 144
Level 25 (2.7.11.1.), p 145
Level 26 (2.7.11.3.), p 145
Level 27 (2.7.11.5.), p 145
Level 28 (2.7.11.7.), p 145
Level 29 (2.7.11.9.), p 145
Level 3 (2.7.8.5.), p 143
Level 30 (2.7.11.11.), p 145
Level 31 (2.7.11.13.), p 145
Level 32 (2.7.11.15.), p 145
Level 4 (2.7.8.7.), p 143
Level 5 (2.7.8.9.), p 143
Level 6 (2.7.8.11.), p 144
Level 7 (2.7.8.13.), p 144
Level 8 (2.7.8.15.), p 144
Level 9 (2.7.9.1.), p 144
Level Override Value (2.9.1.3.), p 156
Level Selector (2.1.2.), p 122
Level Selector (2.12.3.), p 178
Level Selector (2.7.1.), p 140
Level Selector (3.2.6.1.), p 193
Level Setpoint Variation (2.8.2.6.2.), p 153
Level Source (2.8.1.2.), p 146
Loader Revision (3.1.8.), p 191
Local Display Backlight (2.12.1.), p 177
LOE Timer (2.4.2.), p 133
Long Confidence (3.2.9.2.), p 198
Long Echo Threshold (2.11.2.3.), p 167
Long Shot Duration (2.1.10.), p 125
Long Shot Frequency (2.1.8.), p 125
Low Flow Cutoff (2.13.4.8.), p 185
mA Damp Filter (2.6.4.), p 139
mA Fail-safe Mode (2.4.8.), p 135
mA Fail-safe Value (2.4.9.), p 135
mA Input (3.2.6.19.), p 196
mA Input Range (2.6.1.), p 139
mA Output Allocation (2.5.4.), p 136
mA Output Range (2.5.2.), p 136
mA Output Selector (2.4.7.), p 135
mA Output Selector (2.5.1.), p 136
Maintenance and Diagnostics (3.), p 191
Maintenance and Diagnostics (3.), p 191

Parameter name (number), page

Mantissa (2.10.2.2.),	p 159
Manufacture Date (3.1.9.),	p 191
Master Reset (3.2.1.),	p 192
Material (2.1.6.),	p 124
Material Level (2.4.5.),	p 134
Maximum Flow (2.13.4.3.),	p 182
Maximum Head (2.13.4.2.),	p 182
Maximum mA Limit (2.5.8.),	p 137
Maximum Volume (2.7.3.),	p 142
Measurement Values (3.2.6.),	p 193
Measurement Verification (2.11.5.),	p 175
Message (3.1.3.),	p 191
Milliamp Output (2.5.9.),	p 138
Minimum mA Limit (2.5.7.),	p 137
Modem Available (4.9.),	p 203
Modem Inactivity Timeout (4.10.),	p 203
Modifiers (2.8.2.),	p 151
Multiplier (2.10.1.2.),	p 158
Narrow Echo Filter (2.11.2.6.),	p 167
Noise Average (3.2.9.5.),	p 198
Noise Peak (3.2.9.6.),	p 199
Number of Long Shots (2.1.12.),	p 126
Number of Short Shots (2.1.11.),	p 126
OCM Dimension 1 (2.13.5.1.),	p 186
OCM Dimension 2 (2.13.5.2.),	p 186
OCM Dimension 3 (2.13.5.3.),	p 186
OCM Dimension 4 (2.13.5.4.),	p 186
OCM Dimension 5 (2.13.5.5.),	p 186
OCM Dimension 6 (2.13.5.6.),	p 186
OCM Dimension 7 (2.13.5.7.),	p 186
OFF Setpoint (2.8.1.6.),	p 148
Offset Correction (2.11.1.9.),	p 166
Offset Reading (2.12.6.),	p 179
ON Setpoint (2.8.1.5.),	p 148
Order Number (3.1.4.),	p 191
Other Control (2.10.),	p 158
Override Time Delay (2.9.1.4.),	p 156
Parameter Index Location (4.11.),	p 203
Parity (4.6.),	p 202
PMD Dimensions (2.13.5.),	p 186
Power Resumption Delay (2.8.2.8.2.),	p 155
Power-ON Resets (3.2.2.),	p 192
Power-ON Time (3.2.3.),	p 192
Preset Applications (2.8.1.3.),	p 146
Primary Measuring Device (2.13.2.),	p 180
Process Temperature (2.11.1.3.),	p 163
Protocol (4.4.),	p 202
Protocol Selector (5.3.),	p 205
Pump by Rate (2.8.1.8.),	p 149
Pump Group (2.8.2.2.),	p 151
Pump Hours (3.2.7.2.),	p 196
Pump Records (3.2.7.),	p 196
Pump Records (3.2.7.),	p 196
Pump Records (3.2.7.),	p 196
Pump Records (3.2.7.),	p 196
Pump Run Time (3.2.7.3.),	p 196
Pump Run-ON (2.8.2.7.),	p 154

Parameter name (number), page

Pump Run-ONs (3.2.7.5.), p 197
Pump Start Delays (2.8.2.8.), p 154
Pump Starts (3.2.7.4.), p 196
Range Extension (2.2.7.), p 129
Rate (2.3.), p 130
Rate Filter (2.3.5.), p 131
Rate Filter Distance (2.3.7.), p 132
Rate Filter Time (2.3.6.), p 132
Raw mA Input Value (2.6.6.), p 140
Reading (3.2.6.2.), p 193
Reading Minimum (3.2.6.9.), p 194
Reform Echo (2.11.2.5.), p 167
Relay Dead Band (2.8.2.5.), p 152
Relay Duration (2.10.1.3.), p 159
Relay Duration (2.10.2.4.), p 160
Relay Fail-safe (2.8.2.3.), p 152
Relay Function (2.8.1.4.), p 147
Relay Interval Setpoint (2.10.2.6.), p 161
Relay Interval Setpoint (2.8.2.4.), p 152
Relay Logic (2.8.1.11.), p 150
Relay Logic Test (3.2.5.), p 192
Relay Selector (2.10.3.1.), p 161
Relay Selector (2.8.1.1.), p 145
Relay Selector (2.8.2.1.), p 151
Relay Selector (2.8.2.7.2.), p 154
Relay Selector (3.2.4.), p 192
Relay Selector (3.2.7.1.), p 196
Relays (2.8.), p 145
Response Rate (2.3.4.), p 131
Run-ON Duration (2.8.2.7.3.), p 154
Run-ON Interval (2.8.2.7.1.), p 154
Running Totalizer High (2.14.2.), p 189
Running Totalizer Low (2.14.3.), p 190
Scaled mA Input Value (2.6.5.), p 139
Scan Delay (2.1.14.), p 126
Scan Time (2.1.15.), p 127
Security (5.), p 204
Sensor (2.1.), p 122
Sensor Mode (2.1.3.), p 123
Sensor Offset (2.2.5.), p 129
Serial Baud Rate (4.5.), p 202
Serial Number (3.1.5.), p 191
Service Ratio (2.8.1.12.), p 151
Setup (2.), p 122
Shaper Mode (2.11.3.5.), p 172
Short Confidence (3.2.9.3.), p 198
Short Echo Threshold (2.11.2.4.), p 167
Short Shot Bias (2.11.2.10.), p 169
Short Shot Duration (2.1.9.), p 125
Short Shot Floor (2.11.2.11.), p 169
Short Shot Frequency (2.1.7.), p 125
Short Shot Range (2.11.2.12.), p 169
Shot Delay (2.1.16.), p 127
Shot Synchro (2.1.13.), p 126
Shot/pulse Mode (2.1.17.), p 127
Signal Processing (2.11.), p 162
Simulation (3.3.), p 200

Parameter name (number), page

SmartLinx [®] Diagnostics (3.2.10.), p 199
Smartlinx [®] Module Type (3.2.10.4.), p 200
Smartlinx [®] Protocol (3.2.10.5.), p 200
SmartLinx [®] reserved parameters (4.12.1. to 4.12.5.) (4.12.), p 204
Sound Velocity (2.11.1.2.), p 163
Sound Velocity at 20°C (2.11.1.7.), p 165
Space (3.2.6.11.), p 195
Span (2.2.2.), p 127
Spike Filter (2.11.2.7.), p 168
Stop Bits (4.8.), p 203
Submergence Detection (2.11.2.8.), p 168
Table 1-8 (2.13.6.1.), p 186
Table 1-8 (2.7.8.), p 143
Table 17-24 (2.13.6.3.), p 188
Table 17-24 (2.7.10.), p 144
Table 25-32 (2.7.11.), p 145
Table 25-32 (2.13.6.4.), p 188
Table 9-16 (2.13.6.2.), p 187
Table 9-16 (2.7.9.), p 144
Tag (3.1.1.), p 191
Temperature and Velocity (2.11.1.), p 162
Temperature Peak Values (3.2.8.), p 197
Temperature Source (2.11.1.4.), p 163
Temperature Transducer Allocation (2.11.1.5.), p 164
Totalizer Decimal Position (2.14.4.), p 190
Totalizer Multiplier (2.14.5.), p 190
Totalizers (2.14.), p 189
Transducer (2.1.5.), p 124
Transducer Selector (2.1.4.), p 123
Transducer Selector (2.10.1.1.), p 158
Transducer Selector (2.11.1.1.), p 162
Transducer Selector (2.11.2.1.), p 166
Transducer Selector (2.11.3.1.), p 170
Transducer Selector (2.11.5.1.), p 175
Transducer Selector (2.13.1.), p 180
Transducer Selector (2.14.1.), p 189
Transducer Selector (2.3.1.), p 130
Transducer Selector (2.4.1.), p 133
Transducer Selector (2.7.6.), p 143
Transducer Selector (2.8.2.6.1.), p 153
Transducer Selector (2.9.1.1.), p 155
Transducer Selector (3.2.6.10.), p 195
Transducer Selector (3.2.8.1.), p 197
Transducer Selector (3.2.9.1.), p 198
Transducer Temperature (3.2.6.17.), p 196
Transducer Temperature Maximum (3.2.8.2.), p 197
Transducer Temperature Minimum (3.2.8.3.), p 197
TS-3 Temperature (3.2.6.18.), p 196
TS-3 Temperature Maximum (3.2.8.4.), p 197
TS-3 Temperature Minimum (3.2.8.5.), p 198
TVT Brkpt. 1 (2.11.4.1.1.), p 174
TVT Brkpt. 10 (2.11.4.1.10.), p 174
TVT Brkpt. 11 (2.11.4.2.1.), p 174
TVT Brkpt. 12 (2.11.4.2.2.), p 174
TVT Brkpt. 13 (2.11.4.2.3.), p 174
TVT Brkpt. 14 (2.11.4.2.4.), p 174
TVT Brkpt. 15 (2.11.4.2.5.), p 174

Parameter name (number), page

TVT Brkpt. 16 (2.11.4.2.6.), p 174
TVT Brkpt. 17 (2.11.4.2.7.), p 174
TVT Brkpt. 18 (2.11.4.2.8.), p 174
TVT Brkpt. 19 (2.11.4.2.9.), p 174
TVT Brkpt. 2 (2.11.4.1.2.), p 174
TVT Brkpt. 20 (2.11.4.2.10.), p 174
TVT Brkpt. 21 (2.11.4.3.1.), p 174
TVT Brkpt. 22 (2.11.4.3.2.), p 174
TVT Brkpt. 23 (2.11.4.3.3.), p 174
TVT Brkpt. 24 (2.11.4.3.4.), p 174
TVT Brkpt. 25 (2.11.4.3.5.), p 174
TVT Brkpt. 26 (2.11.4.3.6.), p 174
TVT Brkpt. 27 (2.11.4.3.7.), p 174
TVT Brkpt. 28 (2.11.4.3.8.), p 174
TVT Brkpt. 29 (2.11.4.3.9.), p 174
TVT Brkpt. 3 (2.11.4.1.3.), p 174
TVT Brkpt. 30 (2.11.4.3.10.), p 174
TVT Brkpt. 31 (2.11.4.4.1.), p 174
TVT Brkpt. 32 (2.11.4.4.2.), p 174
TVT Brkpt. 33 (2.11.4.4.3.), p 174
TVT Brkpt. 34 (2.11.4.4.4.), p 174
TVT Brkpt. 35 (2.11.4.4.5.), p 175
TVT Brkpt. 36 (2.11.4.4.6.), p 175
TVT Brkpt. 37 (2.11.4.4.7.), p 175
TVT Brkpt. 38 (2.11.4.4.8.), p 175
TVT Brkpt. 39 (2.11.4.4.9.), p 175
TVT Brkpt. 4 (2.11.4.1.4.), p 174
TVT Brkpt. 40 (2.11.4.4.10.), p 175
TVT Brkpt. 5 (2.11.4.1.5.), p 174
TVT Brkpt. 6 (2.11.4.1.6.), p 174
TVT Brkpt. 7 (2.11.4.1.7.), p 174
TVT Brkpt. 8 (2.11.4.1.8.), p 174
TVT Brkpt. 9 (2.11.4.1.9.), p 174
TVT dB (2.11.3.7.), p 172
TVT ms (2.11.3.8.), p 173
TVT Setup (2.11.3.), p 170
TVT Shaper (2.11.4.), p 173
TVT Slope Minimum (2.11.3.9.), p 173
TVT Type (2.11.3.6.), p 172
Units (2.11.), p 122
Universal Head vs. Flow (2.13.6.), p 186
Up Sampling (2.11.5.2.), p 175
User PIN (5.2.), p 204
Vessel Shape (2.7.2.), p 140
Volume (2.7.), p 140
Volume 1 (2.7.8.2.), p 143
Volume 10 (2.7.9.4.), p 144
Volume 11 (2.7.9.6.), p 144
Volume 12 (2.7.9.8.), p 144
Volume 13 (2.7.9.10.), p 144
Volume 14 (2.7.9.12.), p 144
Volume 15 (2.7.9.14.), p 144
Volume 16 (2.7.9.16.), p 144
Volume 17 (2.7.10.2.), p 144
Volume 18 (2.7.10.4.), p 144
Volume 19 (2.7.10.6.), p 144
Volume 2 (2.7.8.4.), p 143

Parameter name (number), page

Volume 20 (2.7.10.8.), p 144
Volume 21 (2.7.10.10.), p 144
Volume 22 (2.7.10.12.), p 144
Volume 23 (2.7.10.14.), p 144
Volume 24 (2.7.10.16.), p 145
Volume 25 (2.7.11.2.), p 145
Volume 26 (2.7.11.4.), p 145
Volume 27 (2.7.11.6.), p 145
Volume 28 (2.7.11.8.), p 145
Volume 29 (2.7.11.10.), p 145
Volume 3 (2.7.8.6.), p 143
Volume 30 (2.7.11.12.), p 145
Volume 31 (2.7.11.14.), p 145
Volume 32 (2.7.11.16.), p 145
Volume 4 (2.7.8.8.), p 143
Volume 5 (2.7.8.10.), p 143
Volume 6 (2.7.8.12.), p 144
Volume 7 (2.7.8.14.), p 144
Volume 8 (2.7.8.16.), p 144
Volume 9 (2.7.9.2.), p 144
Wall Cling Reduction (2.8.2.6.), p 153
Write Protection (5.1.), p 204
Zero Head (2.13.4.5.), p 184

The HydroRanger 200 HMI requires no maintenance or cleaning under normal operating conditions.

Firmware updates

To update the HydroRanger 200 HMI firmware, please contact your Siemens representative to obtain the installer (self-executable **.exe** file). For a complete list of representatives, go to www.siemens.com/processinstrumentation.

Two installers are available: one to update the firmware in the Human Machine Interface (HMI) node, and one for the sensor node. One or both may be required, depending on the reason for the update.

To update, follow the steps below:

1. Connect your computer to the HydroRanger 200 HMI RJ-11 port.
2. Before running the **.exe** installer received from your Siemens representative, note the computer Comm. Port to which the HydroRanger 200 HMI is connected.
3. From your computer, double-click the **.exe** file and follow the installer steps. The first step will prompt for Communication Options. These options are set to factory defaults. Ensure the Comm. Port is set to that noted in step 2 above. No other changes are required.
4. Follow remaining installer steps.
5. Once complete, verify the update was successful by checking the current firmware revision:
 - If updating the **HMI node**, re-cycle the power on the HydroRanger 200 HMI. On power-up, you will see the current HMI firmware revision on the HydroRanger 200 HMI display.
 - If updating the **sensor node**, view parameter *3.1.7. Firmware Revision* (page 185) to see the current sensor node firmware revision.

Before re-entering parameters, complete a *3.2.1. Master Reset* (page 186) to factory defaults after a successful upgrade of the sensor node.

Decontamination declaration

Any device returned to Siemens for repair must be accompanied by a Decontamination Declaration. **With this declaration, you certify that the returned products/spare parts have been carefully cleaned and are free from any residues.**

If the device has been operated together with toxic, caustic, flammable or water-damaging products, clean the device before return by rinsing or neutralizing. Ensure that all cavities are free from dangerous substances. Then, doublecheck that the device completely cleaned.

Siemens will not service a device or spare part unless the declaration confirms proper decontamination of the device or spare part.

Shipments received without a declaration will be cleaned professionally at customer's expense before further processing.

The Decontamination Declaration form can be found online at www.siemens.com/processinstrumentation, under Service > Decontamination Declaration.

Troubleshooting

Notes:

- Many of the parameters referenced and techniques described here require a good understanding of ultrasonic technologies and Siemens echo processing software. Use this information with caution.
- If the setup becomes too confusing, do a *3.2.1. Master Reset* and start again.

Communication troubleshooting

General

1. Check the following:
 - There is power at the device.
 - The HMI is showing the relevant data.
 - The device can be programmed using the local push buttons.
 - If any fault codes are being displayed, see page 218 for a detailed list.
2. Verify that the wiring connections are correct.
3. A HydroRanger 200 HMI parameter is set via remote communications, but the parameter remains unchanged.
 - Try setting the parameter from the local push buttons. If it cannot be set using the buttons, ensure *5.1. Write Protection* is set to the unlock value (1954).

If you continue to experience problems, check the FAQ on our website: www.siemens.com/HydroRanger, or contact your Siemens representative.

General fault codes

Note: If two faults are present at the same time, the device status indicator and text for the fault with the higher priority will display.

HMI icon	Priority	Fault #	Fault text	Cause
	1	14	Trans. 1 Loss of Echo	Point 1 fail-safe.
	2	15	Trans. 2 Loss of Echo	Point 2 fail-safe.
	3	1	TS-3 short (TB:28/29)	TS-3 terminals shorted.
	4	2	Trans. 1 open (TB:1/2)	Transducer 1 open.
	5	3	Trans. 2 open (TB:3/4)	Transducer 2 open.
	6	4	Trans. 1 short (TB:1/2)	Transducer 1 short.
	7	5	Trans. 2 short (TB:3/4)	Transducer 2 short.
	8	6	Trans. 1 short (TB:1/2)	Transducer 1 short.
	9	7	Trans. 2 short (TB:3/4)	Transducer 2 short.
	10	8	Trans. 1 error (TB:1/2)	Transducer 1 specified incorrectly, connections reversed, faulty internal temp sensor.
	11	9	Trans. 2 error (TB:3/4)	Transducer 2 specified incorrectly, connections reversed, faulty internal temp sensor.
	12	10	Point 1 Temp. open	Temp sensor assigned to Point 1 open.
	13	11	Point 2 Temp. open	Temp sensor assigned to Point 2 open.
	14	12	Point 1 Temp. Error	Temp sensor assigned to Point 1 reversed, shorted cable, temp sensor failed.
	15	13	Point 2 Temp. Error	Temp sensor assigned to Point 2 reversed, shorted cable, temp sensor failed.

Common problems chart

Symptom	Possible cause	Action
Display blank, transducer not pulsing	No power, incorrect power	Check mains voltage at terminals. Check fuse. Check wiring connections. Check wiring.
Display blank, transducer is pulsing	Loose or disconnected display cable	Reconnect display cable.
Display active, transducer not pulsing	Incorrect transducer connections or wiring; Incorrect transducer selection (or set to NO Transducer); Transducer has been disabled through the software	Verify terminal connections. Check transducer field wiring. Check any junction box connections. Check that transducer is enabled (see 2.1.5. <i>Transducer</i> on page 118).

Symptom	Cause	Action
Reading fluctuates while material level is still	Material level is changing	Visually verify, if possible.
	Strong false echoes	Determine source of false echoes; relocate transducer to avoid source.
	Incorrect damping	Adjust damping. See <i>2.3.4. Response Rate</i> on page 125.
	Improper echo algorithm selection	Set algorithm to default. If no improvement, try a different algorithm. See <i>2.11.2.2. Algorithm</i> on page 160.
	High noise levels	Verify source and minimize. See <i>Noise problems</i> on page 226.
	Weak echo	Determine cause. Check noise, confidence, and echo strength. See <i>3.2.9. Echo Quality</i> on page 192.
	Foam on surface of material	Eliminate source of foaming. Use stilling well.
	Rapid temperature changes	Use an external temperature sensor. See <i>2.11.1.4. Temperature Source</i> on page 157.
	Faulty temperature sensor	Verify operation; replace if required, or use fixed temperature. See <i>2.11.1.4. Temperature Source</i> on page 157.
Vapors	If fluctuation is unacceptable, consider an alternative technology. Contact your Siemens representative.	

Symptom	Cause	Action
Reading is fixed, but material level changes or reading does not follow material level	Incorrect speed of response	Verify response speed setting is adequate for process (set in Quick Start Wizard, see <i>Response Rate</i> on page 36).
	Loss of Echo condition (LOE)	Check Noise, Echo Strength, Confidence. See <i>3.2.9. Echo Quality</i> on page 192. Ensure that LOE Timer is not set too short. See <i>2.4.2. LOE Timer</i> on page 127.
	Agitator blade stopped in front of transducer (false echo)	Ensure agitator is running.
	Foam on surface of material	Eliminate source of foaming. Use stilling well
	Incorrect Algorithm used	Set algorithm to default. If no improvement, try a different algorithm. See <i>2.11.2.2. Algorithm</i> on page 160.
	Transducer mounting: wrong location or incorrectly mounted	Ensure beam has a clear path to material surface; Verify transducer is not too tight; Use an isolation coupling.
	Incorrect transducer used for the application	Use correct transducer. Contact your Siemens representative.
	Unavoidable false echoes from obstructions	Relocate transducer to ensure beam has a clear path to material surface; use manual TVT shaping or Auto False Echo Suppression. See <i>2.11.4. TVT Shaper</i> on page 167 or <i>2.11.3.2. Auto False Echo Suppression</i> on page 164.

Symptom	Cause	Action
Accuracy varies	Faulty temperature sensor	Verify operation; replace if required, or use fixed temperature. See <i>2.11.1.4. Temperature Source</i> on page 157.
	Vapors present in varying concentrations	Eliminate vapors or consider a different technology. Contact your Siemens representative.
	Thermal gradients	Insulate vessel; consider external temperature sensor.
	Calibration required	If accuracy is better when level is close to transducer, and worse when level is far from it, perform calibration [see <i>2.11.1.8. Auto Sound Velocity</i> on page 159]. If accuracy is consistently incorrect, use <i>2.2.5. Sensor Offset</i> on page 123 or perform calibration.
Reading erratic	Transducer mounting: wrong location or incorrectly mounted	Ensure beam has a clear path to material surface. Verify transducer is not too tight. Use an isolation coupling.
	Unavoidable false echoes from obstructions	Use Auto False Echo Suppression. See <i>2.11.3.2. Auto False Echo Suppression</i> on page 164.
	Confidence too low	Check Noise, Echo Strength, Confidence. See <i>3.2.9. Echo Quality</i> on page 192. Check LOE Timer is not set too short. See <i>2.4.2. LOE Timer</i> on page 127.
	Multiple echoes	Check mounting location; verify material is not entering Blanking range zone. See <i>2.2.6. Blanking</i> on page 123.
	Noise in the application	Verify source and minimize. See <i>Noise problems</i> on page 226.

Symptom	Cause	Action
Incorrect reading (mA output and/or displayed value)	mA function not assigned to correct measurement	Check mA assignment. See <i>2.5.3. Current Output Function</i> on page 130.
	When device is configured for flow: exponent or breakpoint is not correctly selected	Check configuration: if <i>2.1.3. Sensor Mode</i> is set to Flow , verify correct exponent (<i>2.13.4.1. Flow Exponent</i> on page 175) and breakpoints (<i>2.13.6. Universal Head vs. Flow</i> on page 180).
	Incorrect vessel or PMD dimensions	For volume application: verify vessel dimensions. See <i>2.7.2. Vessel Shape</i> on page 134. For flow application: verify PMD dimensions. See <i>2.13.5. PMD Dimensions</i> on page 180
Relay not activating	Relay not programmed	Program relay.
	Incorrect relay setpoints	Verify setpoints.
Relay not activating correctly	Incorrect relay setpoints	Verify setpoints.

Symptom	Cause	Action
Configuration error 130 displayed	<p>Relay/pump configuration errors - possible causes include:</p> <ul style="list-style-type: none"> • A relay is assigned to more than one function (e.g. Relay 2 is assigned to both an external totalizer and a pump). • Pump setpoints are out of order. • Wall cling adjustment range is too large. 	<ul style="list-style-type: none"> • Verify that each relay is assigned to one function only. Review relay assignments under <i>2.8.1.1. Relay Selector</i> on page 139 and <i>2.10. Other Control</i> on page 152. • Verify that all ON setpoints are greater than their respective OFF setpoints for pump down applications (or vica versa for pump up applications). • Ensure range set in <i>2.8.2.6.2. Level Setpoint Variation</i> on page 147 has not caused ON or OFF setpoints to overlap.
Echo profile request results in an error icon that displays for 5 seconds before returning to the echo profile request menu.	Another external communication is trying to access an echo profile at the same time.	Wait for several seconds and then retry the echo profile request, or disconnect / disable any external communications that may be requesting an echo profile.
Display blank, transducer not pulsing.	No power.	Check power supply, wiring, or power fuse.
No response to programmer.	Obstructed infrared interface, defective programmer.	Check programmer usage: 15 cm (6") from faceplate pointed at upper target.
Displays Short and tb:(#) .	Short circuited transducer cable, or defective transducer at indicated terminal block number.	Repair or replace as necessary.
Displays Open and tb:(#) .	Transducer not connected or connection reversed.	Check connection to displayed terminal blocks.
	Open circuited transducer cable, or defective transducer at indicated terminal block number.	Repair or replace as necessary.
Displays LOE .	Weak or non-existent echo.	Relocate and/or re-aim transducer at material.
		Proceed to <i>Measurement difficulties</i> on page 228.
Displays Error and tb:(#) .	Wrong transducer selected (<i>2.1.4. Transducer Selector</i> on page 117.)	Verify transducer type and re-enter value.
	Transducer connected in "two-wire" method.	Do not tie white and shield together. Use all three terminal blocks.
	Transducer connected backwards.	Reverse black and white wires on terminal block.

Displays EEEE	Value too large to display in 4 or 5 characters.	Select larger units (2.1.1. <i>Units</i> on page 116), or lower convert reading (2.12.5. <i>Convert Reading</i> on page 172).
Reading fluctuates while material level is still (or vice versa).	Incorrect measurement stabilization.	Alter rate of response (2.3.4. <i>Response Rate</i> on page 125) or rate filter (2.3.5. <i>Rate Filter</i> on page 125) accordingly.
Reading is fixed, regardless of the actual material level.	Transducer acoustic beam obstructed, standpipe too narrow, or transducer ringing (reads over 100%).	Relocate and / or re-aim transducer at material level or object. Proceed to <i>Measurement difficulties</i> on page 228.
Material level reported is always incorrect by the same amount.	Incorrect empty (zero) reference for level operation (2.1.3. <i>Sensor Mode = *Level</i>).	See 2.2.4. <i>Empty</i> on page 122, 2.12.6. <i>Offset Reading</i> on page 173, 2.2.5. <i>Sensor Offset</i> on page 123, and 2.11.1.9. <i>Offset Correction</i> on page 160.
Measurement accuracy improves as level nears transducer.	Incorrect Sound Velocity used for distance calculation.	Use a transducer with a built-in temperature sensor or a TS-3 temperature sensor. See 2.11.1.2. <i>Sound Velocity</i> on page 157.
Reading is erratic, with little or no relation to material level.	True echo too weak or wrong echo being processed.	Relocate and/or re-aim transducer at material. Check noise parameters. See <i>Noise problems</i> on page 226.

Noise problems

Incorrect readings can be the result of noise problems, either acoustic or electrical, in the application.

The noise present at the input to the ultrasonic receiver can be determined by viewing the echo profile locally via the HMI, or alternatively, using remote software such as SIMATIC PDM. View also parameters *3.2.9.5. Noise Average* and *3.2.9.6. Noise Peak*. In general, the most useful value is the average noise.

With no transducer attached, the noise is under 5 dB. This is often called the noise floor. If the value with a transducer attached is greater than 5 dB, signal processing problems can occur. High noise decreases the maximum distance that can be measured. The exact relationship between noise and maximum distance is dependent on the transducer type and the material being measured. An average noise level greater than 30 dB may be cause for concern if the installed transducer's maximum operation range matches the range of the application (for example: 8 m application using an 8 m XRS-5). Using a larger transducer with greater transmitted energy should help to improve performance in a noise condition.

Determine the noise source

Disconnect the transducer from the HydroRanger 200 HMI. If the measured noise is below 5 dB, then continue reading this section. If the measured noise is above 5 dB, go to *Non-transducer noise sources* below.

1. Connect only the shield wire of the transducer to the HydroRanger 200 HMI. If the measured noise is below 5 dB, continue with the next step. If the noise is above 5 dB, go to *Avoiding common wiring problems*, below.
 2. Connect the white and black transducer wires to the HydroRanger 200 HMI. Record the average noise.
 3. Remove the black wire of the transducer. Record the average noise.
 4. Re-connect the black wire and remove the negative wire. Record the average noise.
- Using the table below, determine the appropriate next step. The terms Higher, Lower and Unchanged refer to the noise recorded in the previous steps.

These are guidelines only. If the suggested solution does not solve the problem, try the other options.

	- Removed	+ Removed	Go to:
Noise	Higher	Higher	<i>Reducing electrical noise on page 227</i>
		Unchanged	<i>Avoiding common wiring problems on page 227</i>
		Lower	<i>Reducing acoustical noise on page 227</i>
	Unchanged	Higher	<i>Reducing electrical noise on page 227</i>
		Unchanged	Contact Siemens representative.
		Lower	<i>Reducing acoustical noise on page 227</i>
	Lower	Higher	<i>Reducing electrical noise on page 227</i>
		Unchanged	<i>Avoiding common wiring problems on page 227</i>
		Lower	<i>Reducing acoustical noise on page 227</i>

Acoustical noise

To confirm that the problem is acoustical, place several layers of cardboard over the face of the transducer. If the noise is reduced, the noise is definitely acoustical.

Non-transducer noise sources

Remove all input and output cables from the HydroRanger 200 HMI individually while monitoring the noise. If removing a cable reduces the noise, that cable may be picking up noise from adjacent electrical equipment. Check that low voltage cables are not being run adjacent to high voltage cables or near to electrical noise generators such as variable speed drives.

Filtering cables is an option but is not recommended unless all others have been exhausted.

The HydroRanger 200 HMI is designed to work near heavy industrial equipment such as variable speed drives. Even so, it should not be located near high voltage wires or switch gear.

Try moving the electronics to a different location. Often, moving the electronics a few meters farther from the source of noise will fix the problem. Shielding the electronics is also an option, but it should be done as a last resort. Proper shielding is expensive and is difficult to install properly—the shielding box must enclose the HydroRanger 200 HMI electronics completely, and all wires must be brought to the box through grounded metal conduit.

Avoiding common wiring problems

- Make sure that the transducer shield wire is connected at the electronics end only. Do not ground it at any other location.
- Do not connect the transducer shield wire to the white wire.
- The exposed transducer shield wire must be as short as possible.
- Connections between the wire supplied with the transducer, and any customer-installed extension wire should only be grounded at the HydroRanger.
- On Siemens transducers, the white wire is negative and the black wire is positive. If the extension wire is colored differently, make sure that it is wired consistently.
- Extension wire must be shielded twisted pair. See the installation section for specifications.

Reducing electrical noise

- Ensure that the transducer cable does not run parallel to other cables carrying high voltage or current.
- Move the transducer cable away from noise generators like variable speed drives.
- Put the transducer cable in grounded metal conduit.
- Filter the noise source.
- Check grounding.

Reducing acoustical noise

- Move the transducer away from the noise source.
- Use a stilling well.
- Install a rubber or foam bushing or gasket between the transducer and the mounting surface.
- Relocate or insulate the noise source.
- Change the frequency of the noise. Ultrasonic devices are sensitive to noise in the frequency range of the transducer employed.
- Check that transducer is not mounted too tightly; hand-tighten only.

Measurement difficulties

If the *2.4.2. LOE Timer* expires due to a measurement difficulty, the *2.4.9. mA Fail-safe Value* displays. In rare cases, the HydroRanger 200 HMI may lock on to a false echo and report a fixed or wrong reading.

Loss of Echo (LOE)

The *2.4.9. mA Fail-safe Value* displays (seen in *2.5.9. Milliamp Output*) when the echo confidence is below the threshold value set in *2.11.2.3. Long Echo Threshold*.

LOE occurs when:

- The echo is lost and no echo is shown above the ambient noise. See **confidence** (*3.2.9.2. Long Confidence* and *3.2.9.3. Short Confidence*) and **echo strength** (*3.2.9.4. Echo Strength*).
- Two echoes are too similar to differentiate (when BLF Best F-L algorithm is used). See **confidence** (*3.2.9.2. Long Confidence* and *3.2.9.3. Short Confidence*) and **echo strength** (*3.2.9.4. Echo Strength*).
- No echo can be detected within the programmed range.

If *2.4.9. mA Fail-safe Value* is displayed, ensure the following conditions:

- Surface monitored is within the transducer maximum range.
- *2.1.5. Transducer* matches the transducer used.
- Transducer is located and aimed properly.
- Transducer that has no submergence shield is not submerged.

Adjust transducer aiming

See the transducer manual for range, mounting, and aiming details. For optimum performance, adjust transducer aiming to provide the best *3.2.9.2. Long Confidence* and *3.2.9.4. Echo Strength* for all material levels within the measurement range.

Displaying echoes

Check for echoes remotely using SIMATIC PDM.

Increase fail-safe timer value

Increase the *2.4.2. LOE Timer* value if fail-safe operation will not be compromised by doing so. Try this only if LOE exists for short periods of time.

Install a transducer with a narrower beam

A consistently incorrect level reading may be due to interference echoes from the sides of a vessel. If this occurs, try installing a longer range (narrower beam) transducer, enter the new transducer model, and (if necessary) optimize aiming and frequency again.

Always contact Siemens service personnel before selecting a transducer to solve this type of problem.

Fixed reading

If the reading is a fixed value, regardless of the transducer to material surface distance, ensure the following conditions:

1. Transducer acoustic beam is free from obstruction.
2. Transducer is properly aimed.
3. Transducer is not in contact with any metal object.
4. Material mixer (if used) and the HydroRanger 200 HMI are operating at the same time. If it the mixer is stopped, make sure that the blade is not stopped under the transducer.

Obstructions in the sound beam

Check for (and remove, if present) any acoustic beam obstruction, or relocate the transducer.

If an obstruction cannot be removed or avoided, adjust the Time Varying Threshold (TVT) curve to reduce the Echo Confidence derived from the sound reflected by the obstruction. Use SIMATIC PDM to adjust the TVT curve.

Nozzle mountings

If the transducer is mounted on or in a nozzle: grind smooth any burrs and welds on the inside or open end (the end that opens into the vessel). If the problem persists, install a larger diameter or shorter length nozzle, bevel the inside of the bottom end, or cut the open end of the nozzle at a 45° angle.

See the transducer manual for complete mounting instructions.

If the mounting hardware is overtightened, loosen it. Overtightening changes the resonance characteristics of the transducer and can cause problems.

Set the HydroRanger 200 HMI to ignore the bad echo

If the preceding remedies have not fixed the problem, the false echo has to be ignored.

If the echo is close to the transducer

If there is a static, incorrect high level reading from the HydroRanger 200 HMI, there is probably something reflecting a strong echo back to the transducer. If the material level never reaches that point, extend the *2.2.6. Blanking* to a distance just past the obstruction.

Adjust the TVT to ignore the echo

Use *2.11.3.2. Auto False Echo Suppression*. If this does not correct the problem, use *2.11.4. TVT Shaper* to manually shape around false echoes.

Wrong reading

If the reading is erratic, or jumps to some incorrect value periodically, ensure the following conditions:

1. Surface monitored is not beyond the HydroRanger 200 HMI's programmed range or the transducer's maximum range.
2. Material is not falling into the transducer's acoustic beam.
3. Material is not inside the blanking distance (*2.2.6. Blanking*) of the transducer.

Types of wrong readings

If a periodic wrong reading always produces the same value, see *Fixed reading* on page 229 .

If the wrong reading is random, ensure the distance from the transducer to the material surface is less than the *2.2.7. Range Extension* value plus one meter (that is, ensure you are still within the measurement range programmed in the device). If the material/object monitored is outside this range, increase *2.2.7. Range Extension* as required. This error is most common in OCM applications using weirs.

Liquid splashing

If the material monitored is a liquid, check for splashing in the vessel. Enter a lower response rate value (see *2.3.4. Response Rate* on page 125) to stabilize the reading, or install a stilling well. Contact your Siemens representative for assistance.

Adjust the Echo Algorithm

Use SIMATIC PDM to view echo profiles and make adjustments to the Algorithm parameter. See *2.11.2.2. Algorithm* on page 160 for details.

If narrow noise spikes are evident on the Echo Profile, widen the *2.11.2.6. Narrow Echo Filter*. Also, if the true echo has jagged peaks, use *2.11.2.5. Reform Echo*.

If multiple echoes appear on the Echo Profile, typical of a flat material profile (especially if the vessel top is domed), use the "TF" (True First) algorithm.

Should a stable measurement is still not attainable, contact your Siemens representative.

Transducer ringing

If the transducer is mounted too tightly, or if it is mounted so that its side touches something (such as a vessel wall, or standpipe), its resonance characteristics change and this can cause problems. Hand tighten only. Using PTFE tape is not recommended as it reduces friction, resulting in a tighter connection that can lead to ringing.

Normal ring down

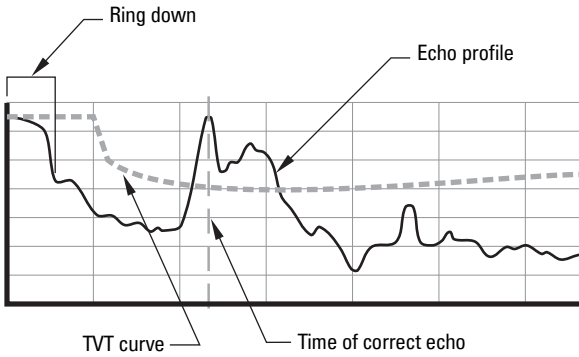

Poor ring down

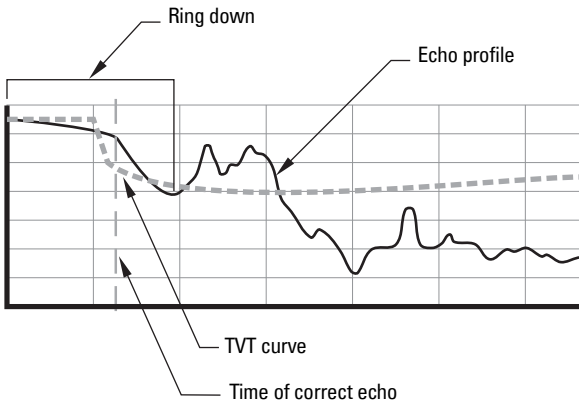

Ring down times that extend into the valid measurement range can be interpreted by the HydroRanger 200 HMI as the material level, and reported as a steady high level.

Unit repair and excluded liability

All changes and repairs must be done by qualified personnel only, and applicable safety regulations must be followed. Please note the following:

- The user is responsible for all changes and repairs made to the device.
- All new components must be provided by Siemens.
- Restrict repair to faulty components only.
- Do not re-use faulty components.

Technical data

Power

AC version

- 100-230 V AC \pm 15%, 50 / 60 Hz, 36 VA (17W)¹
- Fuse: F3: 2 AG, Slow Blow, 0.375A, 250V

DC version

- 12-30 V DC, 20W¹
- Fuse: F3: 2 AG, Slow Blow, 2A, 250V

Mounting

Location

- Indoor / outdoor

Altitude

- 2000 m max.

Ambient temperature

- -20 to 50 °C (-5 to 122 °F)

Relative humidity

- Wall Mount: suitable for outdoors (Type 4X / NEMA 4X, IP65 Enclosure)
- Panel Mount: suitable for outdoors (Type 3 / NEMA 3, IP54 Enclosure)

Installation category

- II

Pollution degree

- 4

Range

- 0.3 m (1 ft) to 15 m (50 ft), dependent on transducer

¹. Power consumption is listed at maximum.

Accuracy¹

- 0.25% of maximum range or 6 mm (0.24"), whichever is greater.

Resolution¹

- 0.1% of program range² or 2 mm (0.08"), whichever is greater.

Memory

- 2 MB static RAM with battery backup
- 1 MB flash EPROM

Programming

Primary

- Local push buttons

Secondary

- PC running SIMATIC PDM

Display

- Backlit HMI LCD display

Temperature compensation

- Range: -50 to 150 °C (-58 to 302 °F)

Source

- Integral transducer sensor
- TS-3 temperature sensor
- Programmable fixed temperature

Temperature error

Sensor

- 0.09 % of range

Fixed

- 0.17 % per °C deviation from programmed value

-
1. Measurement performance under reference operating conditions and configuration.
 2. Program range is defined as the empty distance from the face of the transducer (2.2.4. *Empty*, page 122) plus any range extension (2.2.7. *Range Extension*, page 123).

Outputs

mA Analog

Single- or dual-point versions include two mA outputs

- 0-20 mA
- 4-20 mA
- 750 ohm maximum
- Resolution of 0.1%
- Isolated

Relays¹

- Six:
 - 4-control
 - 2- alarm control
 - All relays rated 5A at 250 V AC, non-inductive.

Control relays

- 4 Form **A**, **NO** relays (numbers 1, 2, 4, 5)

Alarm relay

- 2 Form **C**, **NO**, or **NC** relay (numbers 3, 6)

Communication

- RS-232 running Modbus RTU and ASCII via RJ-11 connector
- RS-485 running Modbus RTU and ASCII via terminal blocks

Optional

- SmartLinX[®] communication card compatible

Inputs

mA (analog) (1)

- 0-20 or 4-20 mA, from alternate device, scalable

Discrete (2)

- 10-50 V DC switching level
- Logical 0 = < 0.5 V DC
- Logical 1 = 10 to 50 V DC
- 3 mA maximum draw

¹ All relays are certified only for use with equipment that fails in a state at or under the rated maximums of the relays.

Enclosure

Wall mount

- 240 mm (9.5") x 175 mm (6.9"). Width dimension includes hinges.
- Type 4X / NEMA 4X / IP65¹
- Polycarbonate

Panel mount

- 278 mm (10.93") x 198 mm (7.8") Width dimension includes flange.
- Type 3 / NEMA 3 / IP54
- Polycarbonate

Weight

- Wall mount: 1.22 kg (2.68 lb)
- Panel mount: 1.35 kg (2.97 lb)

Approvals

- See product nameplate

Compatible transducers

- Echomax series and STH series

Transducer frequency

- 44 kHz

¹ For watertight applications, use only approved, suitable-sized hubs in the enclosure's conduit holes.

Cable

- Using a co-axial cable with the HydroRanger 200 HMI is NOT recommended. If it is really necessary to use such cable, see *Appendix E: Upgrading, Co-axial transducer extension* on page 271 for instructions.
- Transducer and mA output signal to be 2 copper conductors, twisted with shield/drain wire, 300 Vrms, 0.324 - 0.823 mm² (22 - 18 AWG), nominal capacitance between adjacent conductors @ 1kHz = 62.3 pF/m (19 pF/ft). Nominal capacitance between conductor and shield @ 1kHz = 108.3 pF/m (33 pF/ft) (Belden[®] ¹ 8760 is acceptable).
- 365 m maximum

Note: The HydroRanger 200 HMI is to be used only in the manner outlined in this instruction manual or protection provided by the equipment may be impaired.

¹. Belden is a registered trademark of Belden Wire & Cable Company.

Appendix A: Technical reference

Transmit pulse

The transmit pulse consists of one or more electrical “shot” pulses, which are supplied to the transducer connected to the HydroRanger 200 HMI terminals. The transducer fires an acoustic “shot” for each electrical pulse supplied. After each shot is fired, sufficient time is provided for echo (shot reflection) reception before the next (if applicable) shot is fired. After all shots of the transmit pulse are fired, the resultant echoes are processed. The transmit pulse shot number, frequency, duration, delay, and associated measurement range are defined by the following:

Parameter	Page
<i>2.1.17. Shot/pulse Mode</i>	121
<i>2.1.11. Number of Short Shots</i>	120
<i>2.1.12. Number of Long Shots</i>	120
<i>2.1.7. Short Shot Frequency</i>	119
<i>2.1.8. Long Shot Frequency</i>	119
<i>2.1.10. Long Shot Duration</i>	119
<i>2.1.9. Short Shot Duration</i>	119
<i>2.1.1.2.10. Short Shot Bias</i>	163
<i>2.1.1.2.11. Short Shot Floor</i>	163
<i>2.1.1.2.12. Short Shot Range</i>	163

Echo processing

Echo processing consists of echo enhancement, true echo selection, and selected echo verification.

Echo Enhancement is achieved by filtering (*2.1.1.2.6. Narrow Echo Filter* and *2.1.1.2.7. Spike Filter*) and reforming (*2.1.1.2.5. Reform Echo*) the echo profile. The true echo (echo reflected by the intended target) is selected when that portion of the echo profile meets the evaluation criteria of Sonic Intelligence®. Insignificant portions of the echo profile outside of the measurement range (*2.2.2. Span + 2.2.7. Range Extension*), below the TVT Curve (*2.1.1.3.6. TVT Type, 2.1.1.4. TVT Shaper, 2.1.1.3.7. TVT dB, 2.1.1.3.8. TVT ms* and *2.1.1.3.9. TVT Slope Minimum*), and less than the Confidence Threshold (*2.1.1.2.3. Long Echo Threshold*) and Short Shot Floor (*2.1.1.2.11. Short Shot Floor*) are automatically disregarded. The remaining portions of the Echo Profile are evaluated using *2.1.1.2.2. Algorithm* and *2.1.1.2.10. Short Shot Bias*. The Echo Profile portion providing the best Echo Confidence (*3.2.9.2. Long Confidence*) is selected.

True echo verification is automatic. The position (relation in time after transmit) of the new echo is compared to that of the previously accepted echo. When the new echo is within the Echo Lock Window (*2.1.1.5.5. Echo Lock Window*), it is accepted and displays, outputs, and relays are updated per the *2.1.1.5.6. Fuzz Filter* and Rate Parameters (*2.3.2. Fill Rate/minute, 2.3.3. Empty Rate/minute, 2.3.9. Filling Indicator, and 2.3.10. Emptying Indicator*). If the new echo is outside of the Window, it is not accepted until *2.1.1.5.4. Echo Lock* requirements are satisfied.

TVT (Time Varying Threshold) curves

A TVT curve describes a threshold below which any echoes will be ignored. The default TVT curve is used, until *2.11.3.2. Auto False Echo Suppression* and *2.11.3.3. Auto Suppression Range* are used to create a new 'learned TVT curve'.

Auto False Echo Suppression

False echoes can be caused by an obstruction in the beam path (pipes, ladders, chains, and such). Such false echoes may rise above the default TVT curve.

2.11.3.3. Auto Suppression Range allows you to set a distance, and *2.11.3.2. Auto False Echo Suppression* then instructs the HydroRanger 200 HMI to 'learn' where the obstructions/false echoes are within that distance. The new TVT curve is set above the false echoes, screening them out.

Display before Auto False Echo Suppression

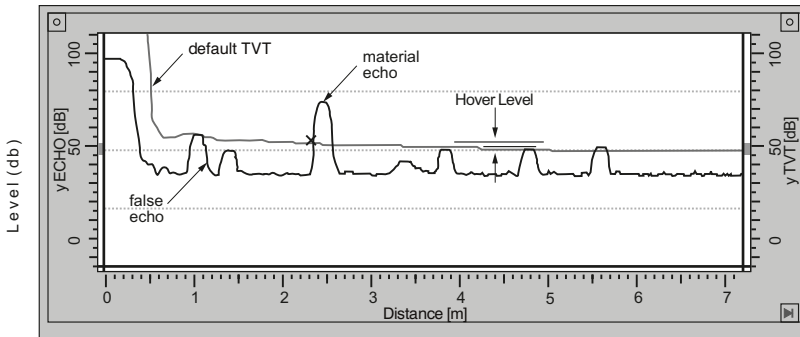

Distance (meters)

Display after Auto False Echo Suppression

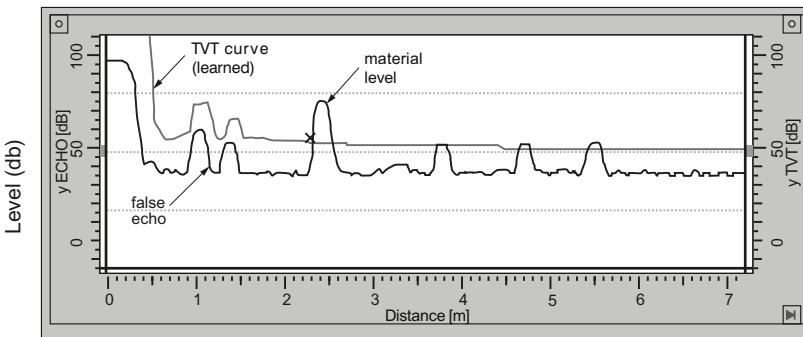

Distance (meters)

Algorithm

The true echo is selected based on the setting for the Echo selection algorithm. For a list of options see *2.11.2.2. Algorithm* on page 160. All algorithms ultimately use confidence to select the true echo.

Below are the preferred algorithm types because they provide the best echo selection results in most applications. Other algorithms (*2.11.2.2. Algorithm* on page 160) may produce better results in specialized applications, but they should only be used after consulting an experienced technical expert.

Algorithm	Echo Determination	Suggested Usage
TF	True First echo Selects the first echo that crosses TVT curve.	Use in liquids applications free of obstructions when confidence of first echo is high.
L	Largest echo Selects the largest echo above the TVT curve.	Use in long range liquids applications with large (tall) material return echoes.
BLF	Best of First and Largest echo Selects the echo (first and highest) with the highest confidence value.	Default and most commonly used. Use in all short to mid range general liquids and solids applications where there is a relatively large (tall), sharp echo.
ALF	Area, Largest, and First Selects the echo with the highest confidence value based on the three criterion (widest, highest, and first).	Use in mid to long range solids applications where the material return echo is wide and large, and where competing smaller echoes challenge BLF

Distance calculation

To calculate the transducer to material level (object) distance, the transmission medium (atmosphere) sound velocity (*2.11.1.2. Sound Velocity*) is multiplied by the acoustic transmission to reception time period. This result is divided by 2, to calculate the one way distance.

$$\text{Distance} = \text{Sound Velocity} \times \text{Time} / 2$$

The Reading displayed is the result of performing any additional modification to the calculated distance, as determined by any of the following:

Parameter	Page
<i>2.1.3. Sensor Mode</i>	117
<i>2.1.1. Units</i>	116
Volume Conversion	
<i>2.7.2. Vessel Shape</i>	134
<i>2.7.3. Maximum Volume</i>	136

2.7.4. Dimension A	136
2.7.5. Dimension L	137
Reading	
2.12.4. Decimal Position	172
2.12.5. Convert Reading	172
2.12.6. Offset Reading	173
OCM	
2.13.2. Primary Measuring Device	174
2.13.4.1. Flow Exponent	175
2.13.5. PMD Dimensions	180
2.13.4.2. Maximum Head	176
2.13.4.3. Maximum Flow	176
2.13.4.5. Zero Head	178
2.13.4.4. Flow Time Units	177
2.13.4.6. Flowrate Decimal	178
2.13.4.7. Flowrate Units	178
2.13.6.1.1. Head 1	180
2.13.6.1.2. Flow 1	181
Totalizer	
2.7.7. Inflow/discharge Adjust	137
2.14.4. Totalizer Decimal Position	184
2.14.5. Totalizer Multiplier	184

Sound Velocity

The sound velocity of the transmission medium is affected by the type, temperature, and vapor pressure of the gas or vapor present. As preset, the HydroRanger 200 HMI assumes the vessel atmosphere is air at 20°C (68°F). Unless altered, the sound velocity used for the distance calculation is 344.1 m/s (1129 ft/s).

Variable air temperature is automatically compensated when a Siemens ultrasonic/temperature transducer is used. If the transducer is exposed to direct sunlight, use a sunshield or a separate TS-3 temperature sensor.

Also, if the temperature varies between the transducer face and the liquid monitored, use a TS-3 temperature sensor (submerged in the liquid) in combination with an ultrasonic / temperature transducer. Set 2.11.1.4. *Temperature Source* for **both**, to average the transducer and TS-3 measurements.

Atmosphere composition other than air can pose a challenge for ultrasonic level measurement. However, excellent results may be obtained by performing a Sound Velocity Calibration (2.11.1.8. *Auto Sound Velocity*) if the atmosphere is homogeneous (well mixed), at a fixed temperature, and under consistent vapor pressure.

The HydroRanger 200 HMI automatic temperature compensation is based on the sound velocity / temperature characteristics of "air" and may not be suitable for the atmosphere present. If the atmosphere temperature is variable, perform frequent Sound Velocity Calibrations to optimize measurement accuracy.

Sound Velocity calibration frequency may be determined with experience. If the sound velocity in two or more vessels is always similar, future calibrations may be performed on one vessel and the resultant Velocity (2.11.1.2. *Sound Velocity*) entered directly for the other vessel(s).

If the sound velocity of a vessel atmosphere is found to be repeatable at specific temperatures, a chart or curve may be developed. Then, rather than performing a Sound Velocity Calibration each time the vessel temperature changes significantly, the anticipated Velocity (2.11.1.2. *Sound Velocity*) may be entered directly.

Scanning

HydroRanger 200 HMI

When echo processing is complete (if more than one vessel is monitored) the scanning relay changes state to supply the transmit pulse to the other transducer after the 2.114. *Scan Delay*.

Scan Delay is automatically set by 2.3.4. *Response Rate*. When high speed scanning is required (sometimes the case for equipment position monitoring), the Scan Delay may be reduced. Reduce the Scan Delay only as required, otherwise premature scanning relay fatigue could occur.

When two transducers are connected and configured in a dual-point unit, the HydroRanger 200 HMI will scan each in turn via the scanner relay. When a single-point HydroRanger 200 HMI is programmed for **differential** or **average** level Operation (2.1.3. *Sensor Mode* = Dual-Point Difference or Dual-Point Average), two transducers of the same type must be used.

Volume calculation

The unit provides a variety of volume calculation features (2.7.2. *Vessel Shape*, 2.7.3. *Maximum Volume*, 2.7.4. *Dimension A*, and 2.7.5. *Dimension L*).

If the vessel does not match any of the eight preset vessel shape calculations, a Universal Volume calculation may be used. Use the level/volume graph or chart provided by the vessel fabricator (or create one based on the vessel dimensions). Based on the graph, choose the Universal Volume calculation, and select the level vs. volume breakpoints to be entered (maximum of 32). Generally, the more breakpoints entered, the greater the accuracy.

Universal Linear

Set 2.7.2. *Vessel Shape* = Universal Linear.

This volume calculation creates a piece-wise linear approximation of the level/volume curve. This option provides best results if the curve has sharp angles joining relatively linear sections.

Enter a Level Breakpoint at each point where the level/volume curve bends sharply (minimum of two).

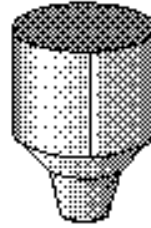

For combination curves (mostly linear but include one or more arcs), enter numerous breakpoints along the arc, for best volume calculation accuracy.

Universal Curved

Set 2.7.2. *Vessel Shape* = Universal Curved.

This calculation creates a cubic spline approximation of the level/volume curve, providing best results if the curve is non-linear, and there are no sharp angles.

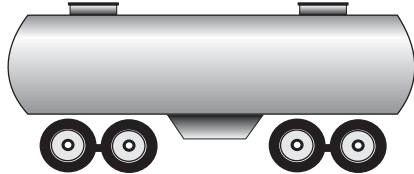
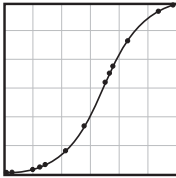

Select at least enough breakpoints from the curve to satisfy the following:

- Two breakpoints very near the minimum level.
- One breakpoint at the tangent points of each arc.
- One breakpoint at each arc apex.
- Two breakpoints very near the maximum level.

For combination curves, enter at least two breakpoints immediately before and after any sharp angle (as well as one breakpoint exactly at the angle) on the curve.

Flow calculation

The HydroRanger 200 HMI provides numerous OCM flow calculation features:

Parameter	Page
2.13.2. <i>Primary Measuring Device</i>	174
2.13.4.1. <i>Flow Exponent</i>	175
2.13.5. <i>PMD Dimensions</i>	180
2.13.4.2. <i>Maximum Head</i>	176
2.13.4.3. <i>Maximum Flow</i>	176
2.13.4.5. <i>Zero Head</i>	178
2.13.4.4. <i>Flow Time Units</i>	177
2.13.4.6. <i>Flowrate Decimal</i>	178
2.13.4.7. <i>Flowrate Units</i>	178
2.13.6.1.1. <i>Head 1</i>	180
2.13.6.1.2. <i>Flow 1</i>	181

If the PMD (primary measuring device) does not match any of the eight preset PMD calculations, or if a PMD is not used, select a Universal Volume calculation. Use the head/flow graph or chart provided by the PMD fabricator (or create one based on the PMD or channel dimensions).

Based on the graph, choose the Universal Flow calculation, and select the head versus flow breakpoints to be entered (maximum of 32). Generally, the more breakpoints entered, the greater the flow calculation accuracy.

Universal Linear

Set 2.13.2. *Primary Measuring Device* = Universal Linear Flow Calculation.

This flow calculation creates a piece-wise linear approximation of the head/flow curve. This option provides best results if the curve has sharp angles joining relatively linear sections.

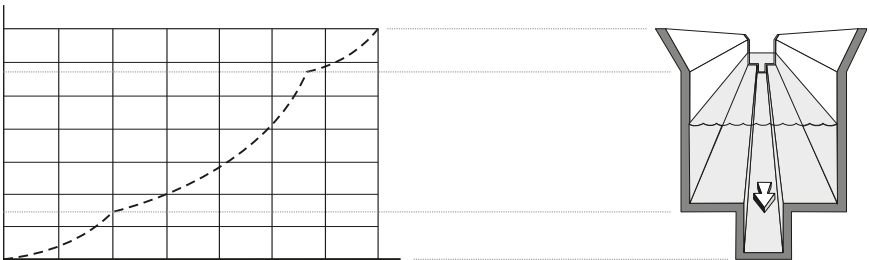

Enter a Head Breakpoint at each point where the head/flow curve bends sharply (minimum of two). For combination curves (mostly linear but include one or more arcs), enter numerous breakpoints along the arc, for best flow calculation accuracy.

See also *Typical flow characterization* on page 107.

Universal Curved

This calculation creates a cubic spline approximation of the head/flow curve, providing best results if the curve is non-linear, and there are no sharp angles.

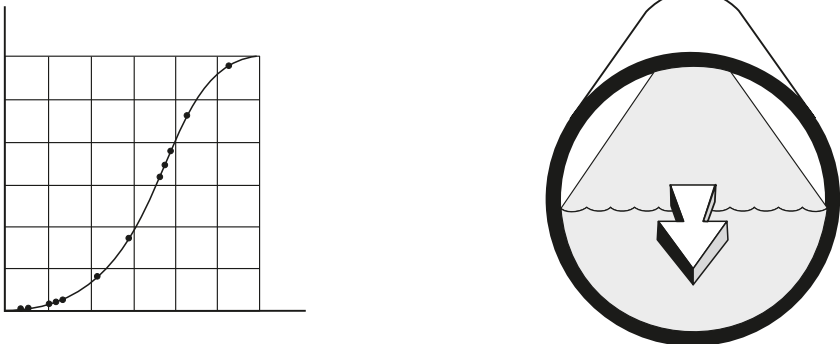

Select at least enough breakpoints from the curve to satisfy the following:

- Two breakpoints very near the minimum head.
- One breakpoint at the tangent points of each arc.
- One breakpoint at each arc apex.
- Two breakpoints very near the maximum head.

For combination curves, enter at least two breakpoints immediately before and after any sharp angle (as well as one breakpoint exactly at the angle) on the curve. For more information, see *Typical flow characterization* on page 107.

Response Rate

The HydroRanger 200 HMI's ability to respond to material level changes is designed to exceed even the most demanding installation requirements.

The *2.3.4. Response Rate* setting automatically presets various parameters affecting the HydroRanger 200 HMI response to material level changes as follows:

Parameter (units)	Values dependent on Response Rate		
	Slow	Medium	Fast
<i>2.4.2. LOE Timer</i> (min)	100	10	1
<i>2.3.2. Fill Rate/minute</i> (m/min)	0.1	1	10
<i>2.3.3. Empty Rate/minute</i> (m/min)	0.1	1	10
<i>2.3.9. Filling Indicator</i> (m/min)	0.01	0.1	1
<i>2.3.10. Emptying Indicator</i> (m/min)	0.01	0.1	1
<i>2.3.5. Rate Filter</i> (option)	10 min or 300 mm (11.8 in)	*1 min or 50 mm (2 in)	*1 min or 50 mm (2 in)
<i>2.11.5.6. Fuzz Filter</i> (% of Span)	100	50	10
<i>2.11.5.5. Echo Lock Window</i>	(per <i>2.3.3. Empty Rate/minute</i> <i>2.3.9. Filling Indicator</i> and time since last valid measurement)		
<i>2.1.14. Scan Delay</i> (seconds)	5	5	3
<i>2.1.12. Number of Long Shots</i>	10	5	2

If any of these parameters are independently altered, a *2.3.4. Response Rate* parameter alteration automatically resets the independently altered value.

Slower *2.3.4. Response Rate* provides greater measurement reliability.

Faster performance may be obtained by independently setting *2.3.2. Fill Rate/minute* and *2.3.3. Empty Rate/minute*. Maximum rates may be impeded by *2.11.5.4. Echo Lock*, *2.1.14. Scan Delay*, and *2.1.16. Shot Delay* values.

Analog Output

The mA output (current output) is proportional to material level in the range 4 to 20 mA. 0% and 100% are percentages of the full-scale reading (m, cm, mm, ft, in). Typically, mA output is set so that 4 mA equals 0% and 20 mA equals 100%.

Current Output Function

2.5.3. Current Output Function controls the mA output and applies any relevant scaling. By default, it is set to Level. Other options are Space, Distance, Volume, Flow, or Head.

You can also set the mA output to report when the device is in an error condition and the fail-safe timer has expired. By default, the reported value depends on the device type. A standard device reports the last valid reading, and a NAMUR NE43 compliant device reports the user-defined value for *2.4.9. mA Fail-safe Value* (3.58 mA by default).

Loss of Echo (LOE)

A loss of echo (LOE) occurs when the calculated measurement is judged to be unreliable because the echo confidence value has dropped below the echo confidence threshold.

If the LOE condition persists beyond the time limit set in *2.4.2. LOE Timer*, the LCD displays the Service Required icon, and the text region displays the fault code **0** and the text **LOE**.

If two faults are present at the same time, the device status indicator and text for the highest priority fault will display. For example, if both Loss of Echo and Broken cable faults are present, the Broken cable fault will display.



1 Broken cable

Fail-safe Mode

The purpose of the Fail-safe setting is to put the process into a safe mode of operation in the event of a fault or failure. The value to be reported in the event of a fault (as displayed in *2.5.9. Milliamp Output*) is selected so that a loss of power or loss of signal triggers the same response as an unsafe level.

2.4.2. LOE Timer determines the length of time a Loss of Echo (LOE) condition will persist before a fail-safe state is activated. The default setting is 100 seconds.

2.4.5. Material Level determines the mA value (corresponding to the selected PV) to be reported when *2.4.2. LOE Timer* expires.

Upon receiving a reliable echo, the loss of echo condition is aborted, the Maintenance Required icon and error message are cleared, and the mA output returns to the current material level. [The Primary reding on the HMI display will show dashes (----) when a fault that causes fail-safe is present, and will return to the current reading when the fault is cleared.]

Appendix B: Pump control reference

The HydroRanger 200 HMI has the pump control strategies to suit nearly any water/wastewater application. This section details these strategies for engineers requiring in-depth knowledge of the system and how it operates.

Pump control options

The various methods of pump control are made up of a combination of two control variables:

Pump duty

Indicates in what sequence pumps are started.

Pump start method

Indicates whether new pumps start and run with any currently running pumps (most common) or whether new pumps start and shut off currently running pumps.

Pump groups

The HydroRanger 200 HMI groups pumps that use identical pumping strategies based on the value of Relay Control Function (*2.8.1.4. Relay Function*). Generally, one group of pumps corresponds to one wet well or reservoir.

Pump by rate

To trigger pump starts by the rate of change in material level, use *2.8.1.8. Pump by Rate*. New pumps are started, one at a time, until the rate setpoint (*2.3.9. Filling Indicator*, or *2.3.10. Emptying Indicator*) is reached.

Pump control algorithms

Fixed

Starts pumps based on individual setpoints and always starts the same pumps in the same sequence.

Alternate

Starts pumps based on the duty schedule and always leads with a new pump.

Service Ratio

Starts pumps based on user-defined ratio of running time.

Fixed Duty Assist

2.8.1.4. *Relay Function = Fixed Duty Assist ties the indexed pump relay directly to the indexed setpoint.*

Relay operation (for 2.8.1.11. *Relay Logic = Positive*)

The relay contact closes at the ON setpoint and opens at the OFF setpoint. Multiple relay contacts in the pump group can be closed at the same time.

Relay table

The following table shows relay status when each setpoint is reached.

Setpoints	Index	Relays		
		1	2	3
	ON 3	ON	ON	ON
	ON 2	ON	ON	OFF
	ON 1	ON	OFF	OFF
	OFF	OFF	OFF	OFF

Fixed Duty Backup

2.8.1.4. *Relay Function = Fixed Duty Backup ties the indexed pump relay directly to the indexed setpoint.*

Relay operation (for 2.8.1.11. *Relay Logic = Positive*)

The relay contact closes at the ON setpoint and opens at the OFF setpoint. When a new relay trips the previously closed relay contact opens to shut down the running pump.

Only one relay contact in the pump group can be closed at any one time.

Relay table

The following table shows relay status when each setpoint is reached.

Setpoints	Index	Relays		
		1	2	3
	ON 3	OFF	OFF	ON
	ON 2	OFF	ON	OFF
	ON 1	ON	OFF	OFF
	OFF	OFF	OFF	OFF

Alternate Duty Assist

2.8.1.4. *Relay Function = Alternate Duty Assist alternates the lead pump each time the material level cycles and runs all pumps together.*

Relay operation
(for 2.8.1.11. *Relay Logic = Positive*)

The setpoints associated with the relays are grouped so that they can be rotated.

Setpoint 1 does not relate directly to Relay 1. The pumping algorithm manages the mapping of setpoints to relays.

When pumps are run, they RUN in parallel.

Relay table

Cycle 1		Relays		
		1	2	3
Setpoints	ON 3	ON	ON	ON
	ON 2	ON	ON	OFF
	ON 1	ON	OFF	OFF
	OFF	OFF	OFF	OFF
Cycle 2		Relays		
		1	2	3
Setpoints	ON 3	ON	ON	ON
	ON 2	OFF	ON	ON
	ON 1	OFF	ON	OFF
	OFF	OFF	OFF	OFF
Cycle 3		Relays		
		1	2	3
Setpoints	ON 3	ON	ON	ON
	ON 2	ON	OFF	ON
	ON 1	OFF	OFF	ON
	OFF	OFF	OFF	OFF

Alternate Duty Backup

2.8.1.4. *Relay Function = Alternate Duty Backup alternates the lead pump each time the material level cycles.*

Relay operation
(for 2.8.1.11. *Relay Logic = Positive*)

The setpoints associated with the relays are grouped so that they can be rotated.

Setpoint 1 does not relate directly to Relay 1. The pumping algorithm manages the mapping of setpoints to relays. When pumps are run, they can RUN only one at a time.

Relay table

Cycle 1		Relays		
		1	2	3
Setpoints	ON 3	OFF	OFF	ON
	ON 2	OFF	ON	OFF
	ON 1	ON	OFF	OFF
	OFF	OFF	OFF	OFF
Cycle 2		Relays		
		1	2	3
Setpoints	ON 3	ON	OFF	OFF
	ON 2	OFF	OFF	ON
	ON 1	OFF	ON	OFF
	OFF	OFF	OFF	OFF
Cycle 3		Relays		
		1	2	3
Setpoints	ON 3	OFF	ON	OFF
	ON 2	ON	OFF	OFF
	ON 1	OFF	OFF	ON
	OFF	OFF	OFF	OFF

Service Ratio Duty Assist

2.8.1.4. Relay Function = Service Ratio Duty Assist selects the lead pump based on number of hours each pump has run and the specified ratios that each pump requires. Multiple pumps can run at one time.

Relay operation

(for 2.8.1.1. Relay Logic = Positive)

The setpoints associated with the relays are grouped so they can be redistributed based on pump RUN time ratios. The next pump to start or stop is the one with the required time to actual time ratio.

Over time, the number of hours demanded of each pump will conform to the ratios specified. Usually, the ratios are specified in percent values.

To create a grouping of pumps where two pumps make up 50% of the run time and the third pump makes up the other 50%, 2.8.1.2. *Service Ratio* is set to the following:

Relay Index	Value
1	25
2	25
3	50

Service Ratio Duty Backup

2.8.1.4. Relay Function = Service Ratio Duty Backup selects the lead pump based on the number of hours each pump has run and the specified ratios that each pump requires. Only one pump can run at a time.

This algorithm is the same as Service Ratio Duty Assist except that it will **run only one** pump at a time. When the next pump in the sequence starts, the previous pump stops.

First In First Out

*2.8.1.4. Relay Function = First In First Out selects the lead pump based on the **Alternate** duty, but uses staggered OFF setpoints and shuts down pumps based on the **first in, first out** rule.*

This algorithm starts pumps in the same way as Alternate Duty Assist but uses staggered OFF setpoints to shut the pumps down. When the first OFF setpoint is reached, the FIFO rule shuts down the first pump started. For example: pumps started in sequence 2,3,1 would be shut down in sequence 2,3,1.

Pump by Rate

Pump by Rate (2.8.1.8.) starts pumps until the level is changing at the rate specified in 2.3.9. Filling Indicator or 2.3.10. Emptying Indicator.

Pumping costs can be less because only the highest ON setpoint needs to be programmed and this results in a lower difference in Head to the next wet well which, in turn, results in less energy being used to pump out the well.

Other pump controls

There are a number of other controls available to modify pump behavior.

Pump Run-ON

(2.8.2.7.1. Run-ON Interval, 2.8.2.7.3. Run-ON Duration)

Extends the RUN period for a pump based on a set time interval. This allows for the wet well to be pumped lower than usual, and reduces sludge build-up on the well bottom.

Wall Cling Reduction

(2.8.2.6.2. Level Setpoint Variation)

Varies the ON and OFF setpoints to keep a fat ring from forming around the walls of the wet well.

Pump Group

(2.8.2.2. Pump Group)

Allows for two different Alternate Duty Assist or Alternate Duty Backup pump groups in the same application.

Flush Device

(2.10.3.2. Flush Pump, 2.10.3.3. Flush Cycles, 2.10.3.4. Flush Interval, 2.10.3.5. Flush Duration)

Operates a flush valve or special flush device based on the number of pump starts, usually to aerate wet well wastewater.

Appendix C: Communications

HydroRanger 200 HMI communication systems

The HydroRanger 200 HMI is an integrated level controller capable of communicating process information to a Supervisory Control and Data Acquisition (SCADA) system, via a serial device such as a radio modem, leased line, or dial-up modem.

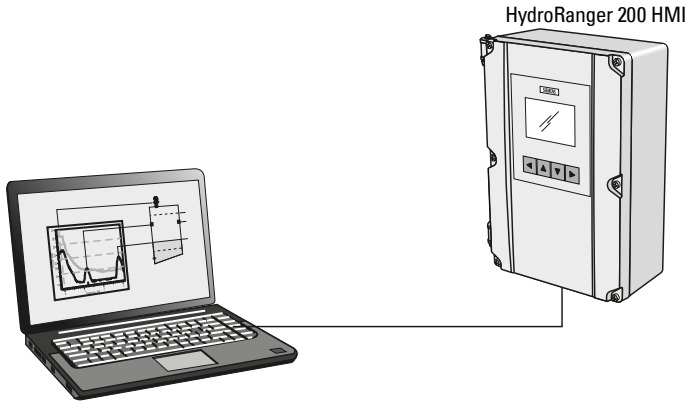

Connection via radio modem, dial-up modem, or leased line modem

Modbus

The HydroRanger 200 HMI supports the Modbus protocol, an industry standard used by SCADA and HMI systems. HydroRanger 200 HMI uses Modbus to communicate via the RS-485 port.

Optional SmartLinx[®] Cards

The standard HydroRanger 200 HMI unit may also be enhanced with Siemens SmartLinx[®] communication modules that provide an interface to popular industrial communication systems.

This manual only describes the built-in communications. Please consult the appropriate SmartLinx[®] manual for other information.

Communication systems

The HydroRanger 200 HMI is capable of communicating with most SCADA systems, PLCs, and PCs. The supported protocols are:

- Modbus RTU/ASCII – built-in, supported on both RS-232 and RS-485 ports.
- PROFIBUS DPV0 – optional SmartLinx[®] module.
- PROFIBUS DPV1 – optional SmartLinx[®] module.
- DeviceNet[®] ¹ – optional SmartLinx[®] module.

¹ DeviceNet is a registered trademark of Open DeviceNet Vendor Association.

Communication ports

The HydroRanger 200 HMI comes with two communications ports on the base unit.

Port	Connection	Location	Interface
1	RJ-11 connector	Inside enclosure on main board.	RS-232
2	Terminal block	Terminal block	RS-485

RS-232

Note: The RS-232 port is not intended for connection to a network (bus). Use it only for direct connection to a laptop, PC, or modem.

The RJ-11 jack connects to a laptop computer for the following:

- Initial setup
- Configuration
- Troubleshooting
- Periodic maintenance
- Firmware updates

RS-485

The RS-485 port on the terminal blocks connects into industrial communications wiring and has the following advantages:

- Runs communications cable farther
- Allows multiple slave units on the network, addressed by parameter *4.2. Device Address*.

Modbus

The Modbus protocol is supported in the base unit and can be configured using the *4. Communication* parameters on page 195.

To set up communications with a Modbus RTU master device on Port 2 using RS-485, set the following parameters:

Parameter	Index	Value/Mode
<i>4.4. Protocol</i>	2	*Modbus RTU slave serial
<i>4.2. Device Address</i>	2	1
<i>4.5. Serial Baud Rate</i>	2	9.6 kbaud
<i>4.6. Parity</i>	2	No Parity
<i>4.7. Data Bits</i>	2	8 data bits
<i>4.8. Stop Bits</i>	2	1 stop bit
<i>4.9. Modem Available</i>	2	No modem connected
<i>4.11. Parameter Index Location</i>	2	Global

SmartLinX®

Other protocols are available through optional SmartLinX® communications modules. Details on how to install and program these modules are contained in the SmartLinX® documentation.

Communications installation

Wiring guidelines

- The RJ-11 cable maximum length is 3 meters.
- RS-485 maximum length is 1,200 meters (4,000 feet).
- Use 24 AWG (minimum).
- Use good quality communication grade (shielded twisted pairs) cable that is recommended for RS-485 for port 2 (Belden 9842).
- Run the communication cable separately from power and control cables (do not tie wrap your RS-232 or RS-485 cable to the power cable or have them in the same conduit).
- Use shielded cable and connect to ground at one end only.
- Follow proper grounding guidelines for all devices on the bus.

Note: Improper wiring and incorrect choice of cables are two of the most common causes of communication problems.

Ports 1 and 2

Port	Wall mount
1	RS-232 port (RJ-11 modular telephone jack) is generally used with a laptop computer or modem.
2	Connections for the RS-485 port are on the terminal block.

Ports 1 and 2: RS-232 RJ-11 jack and RS-485 locations

The RJ-11 jack and the RS-485 port are inside the enclosure of the unit.

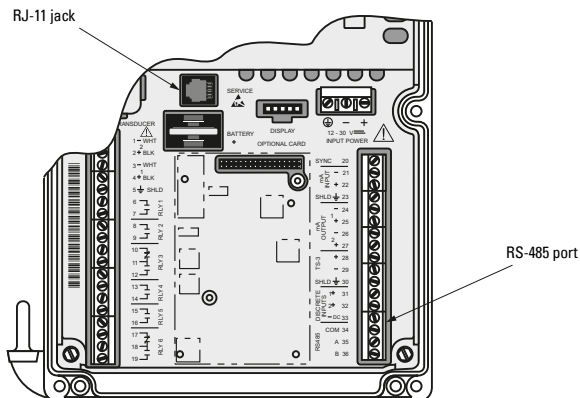

Port 1: RS-232 RJ-11 jack

To connect the unit to a PC using an RS-232 jack, use the cable as shown:

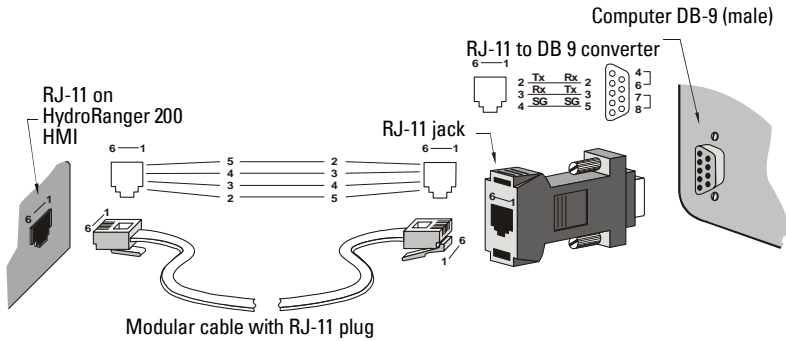

Note: Jumper pins 4-6 and 7-8 at the DB-9.

To connect the unit to a modem using an RS-232 jack:

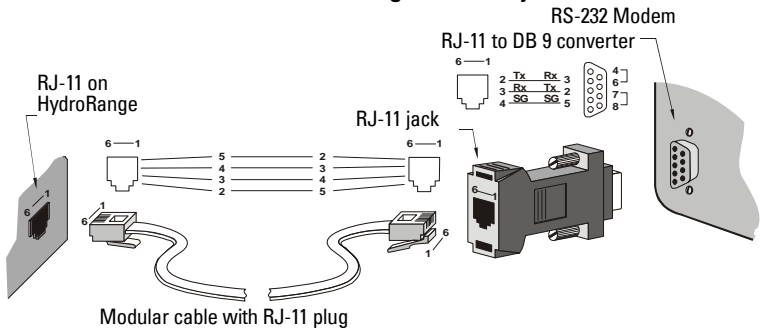

Note: Jumper pins 4-6 and 7-8 at the DB-9.

Port 2: RS-485

To connect the unit to an RS-232 modem:

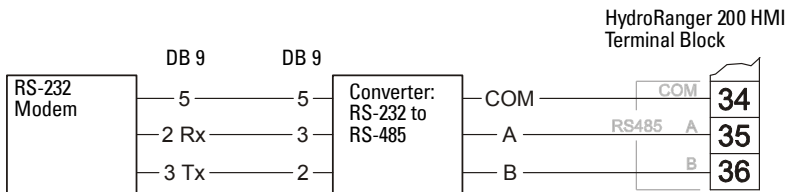

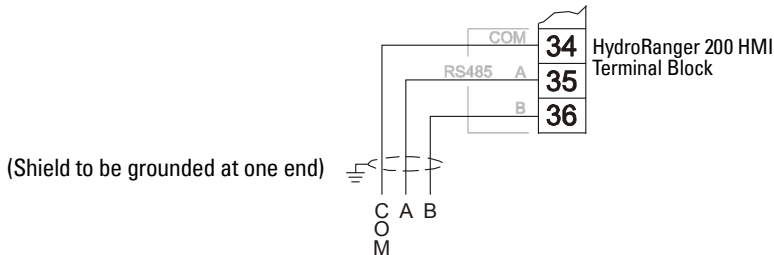

To connect the unit to a modem using an RS-485 port:

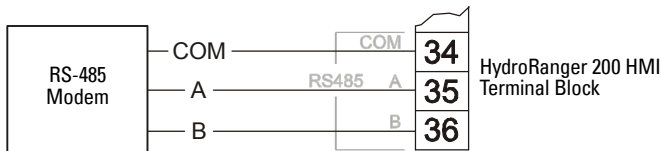

Configuring communications ports (parameters)

The parameters listed below are indexed to the two communications ports, unless otherwise noted.

Port	Description
1	RS-232 port (RJ-11 modular telephone)
2	The RS-485 port is on the terminal blocks

Parameter	Page
<i>4.4. Protocol</i>	196
<i>4.2. Device Address</i>	195
<i>4.5. Serial Baud Rate</i>	196
<i>4.6. Parity</i>	196
<i>4.7. Data Bits</i>	197
<i>4.8. Stop Bits</i>	197
<i>4.9. Modem Available</i>	197
<i>4.10. Modem Inactivity Timeout</i>	197
<i>4.11. Parameter Index Location</i>	197

SIMATIC Process Device Manager (PDM)

SIMATIC PDM is a software package for parameterizing, commissioning, diagnosing and maintaining process devices. For the HydroRanger 200 HMI, SIMATIC PDM connects directly to the device using Modbus over Port 1 (the RJ-11 jack) or Port 2 (RS-485 on the terminal block).

The HydroRanger 200 HMI comes with Port 1 (the RJ-11 jack) set for communications to SIMATIC PDM.

SIMATIC PDM contains a simple process monitor of the process values, alarms and status signals of the device. Using SIMATIC PDM, you can do the following to process device data:

- Display
- Set
- Change
- Compare
- Check the plausibility
- Manage
- Simulate

More information about SIMATIC PDM is available at www.siemens.com/processinstrumentation: go to Communication and Software > Process Device Manager. Please consult the operating instructions or online help for details on using SIMATIC PDM. An Application Guide on using HydroRanger 200 HMI with PDM and Modbus is available on our website: www.siemens.com/processinstrumentation.

Device description

To use Process Device Manager (PDM) with HydroRanger 200 HMI, you need the Device Description for HydroRanger, which will be included with new versions of PDM. You can locate the Device Description in **Device Catalog**, under **Sensors/Level/ Echo/Siemens Milltronics**. If you do not see HydroRanger under Siemens Milltronics, you can download it from our website: www.siemens.com/processinstrumentation. Go to the HydroRanger 200 HMI product page and click Downloads.

Modbus register map

The memory map of the HydroRanger 200 HMI occupies the Modbus holding registers (R40,001 and up). This map is used when the protocol is Modbus RTU slave or Modbus ASCII slave.

Register map for most common data

Legend	
Type	The type of data held in the group of registers.
Start	The first register to hold the referenced data.
Data type	The possible values of the data in the register. See <i>Data types on page 268</i> for more information.
Description	The type of data held in the individual registers.
#R	The number of registers used for the referenced data.
Read/Write	Indicates whether the register is readable, writeable or both.

Type	Description	Start	#R ¹	Data type	Read/Write
	Word order	40,062		0/1	R/W
Map ID	Register map type	40,063	1	0/1 = P782	R/W
ID	Siemens Product Code	40,064	1	4 = HydroRanger 200 HMI	R
Single Parameter Access (SPA)		R40,090	7	See <i>Single Parameter Access (SPA)</i> on page 274.	
Point	Reading (3) ²	41,010	2	-20,000 to 20,000	R
Data	Volume (2) ³	41,020	2	-20,000 to 20,000	R

1. Maximum registers shown; fewer may be used depending on options installed.
2. **HydroRanger 200 HMI:** Available as Reading 1, Reading 2, and Average or Difference when in either single- or dual-point mode. In single-point mode, Points 2 and 3 are only available if 2.1.3. *Sensor Mode* = Dual-Point Average or Dual-Point Difference. In dual-point mode, Readings 1 and 2 are always available. Point 3 is only available if 2.1.3. *Sensor Mode* [3] = Dual-Point Average or Dual-Point Difference.
3. 2nd volume available in dual-point mode only.

Type	Description	Start	#R ¹	Data type	Read/Write
Point data	Temperature (2)	41,030	2	-50 to 150	R
	Totalizer for Points 1 and 2	41,040	4	UINT32	R/W
I/O	Discrete Inputs (2)	41,070	1	Bit Mapped	R
	Relay Outputs (3 or 6)	41,080	1	Bit Mapped	R/W
	mA Input (1)	41,090	1	0000 to 20,000	R
	mA Output (2)	41,110	2	0000 to 20,000	R/W
Pump Control	Pump ON Setpoint (3 or 6)	41,420	6	0000 to 10,000	R/W
	Pump OFF Setpoint (3 or 6)	41,430	6	0000 to 10,000	R/W
	Pumped Volume (2)	41,440	4	UINT32	R
	Pump Hours (3 or 6)	41,450	12	UINT32	R
	Pump Starts (3 or 6)	41,470	6	0000 to 10,000	R
Parameter Access		43,998 to 46999			R/W

1. Maximum registers shown; fewer may be used depending on options installed.

The HydroRanger 200 HMI was designed to make it easy for master devices to get useful information via Modbus. This chart gives an overview of the different sections. A more detailed explanation of each section follows below.

Word order (R40,062)

This determines the format of unsigned, double-register integers (UINT32).

- **0** indicates that the most significant word (MSW) is given first
- **1** indicates that the least significant word (LSW) is given first

See *Unsigned double precision integer (UINT32)* on page 268 for more information.

Map ID (R40,063)

This value identifies the register map used by the HydroRanger 200 HMI. See 4.11. *Parameter Index Location* on page 197, and *Parameter access (R43,998 – R46,999)* on page 263 for details.

Product ID (R40,064)

This value identifies the Siemens device type:

Device Type	Value
HydroRanger 200 HMI	32

Point data (R41,010 – R41,031)

Level Point data contain the current instrument readings. These are the values shown for the reading measurement for each Level Point. The reading is based on the setting for *2.1.3. Sensor Mode*, which can be set to **Level**, **Distance**, **OCM Flow**, or **Volume**. See page 117 for details.

The measurement registers are 41,010 to 41,012. The HydroRanger 200 HMI uses 41,010 when configured with a single transducer and 41,010 to 41,012 when configured with two transducers (*2.8.1.4. Relay Function* = Rate of Change or Temperature only). Two transducers can create three readings because they can generate an average or differential reading (R41,012) as well as the two level readings (R41,010 and R41,011).

Available registers:

Data	Registers	Parameter
Reading	41,010 to 41,012	<i>3.2.6.2. Reading</i>
Volume	41,020, 41,021	<i>3.2.6.13. Head</i>
Temperature	41,030 and 41,031	<i>3.2.6.17. Transducer Temperature</i>

The reading is expressed as a percentage of full scale, multiplied by 100:

Reading	Value
0	0.00%
5000	50.00%
7564	75.64%
20,000	200.00%

Totalizer (R41,040 – R41,043)

The totalizers are stored as 32-bit integers using two registers. The totalizers can be read with R41,040 and R41,041 as totalizer for Point 1, and R41,042 and R41,043 as totalizer for Point 2. The totalizer values can be reset to any value by writing that value to the registers. The values can be cleared by writing zero (0) to the registers.

Input/Output (R41,070 – R41,143)

The HydroRanger 200 HMI has discrete inputs, mA inputs, mA outputs and relay outputs. See below for details for each I/O type.

Discrete inputs (R41,070)

This table shows the current status of the discrete inputs. Only register 41,070 is used.

Discrete Input	Data Address
1	41,070, bit 1
2	41,070, bit 2

Relay outputs (R41,080)

This table shows the current status of the relays. A reading of **0** means that the relay function is not asserted and a **1** means that it is asserted. For example, a **1** for a pump relay means that the pump is running.

Relay	Data Address
1	41,080, bit 1
2	41,080, bit 2
3	41,080, bit 3
4	41,080, bit 4
5	41,080, bit 5
6	41,080, bit 6

Values are written to control a relay only if the Relay Control Function (2.8.1.4. *Relay Function*) is set to Communication. See *Relay function codes* (2.8.1.4. *Relay Function Only*) on page 271.

mA Input (R41,090)

The mA input is scaled from 0 to 2,000 (0 to 20 mA multiplied by 100). Parameter 2.6.5. *Scaled mA Input Value* displays the value of the input. It is indexed by the input number.

mA Output (R41,110-41,111)

The mA output is scaled from 0 to 2,000 (0 to 20 mA multiplied by 100). This is displayed in 2.5.9. *Milliamp Output*.

Pump control (R41,400 – R41,474)

Only relays set for pump control (2.8.1.4. *Relay Function*= Fixed Duty Assist, Fixed Duty Backup, or Alternate Duty Assist) are available. These registers have no effect on relays programmed for other uses.

Pump ON setpoint (R41,420 – R41,425)

The ON setpoint level (2.8.1.5. *ON Setpoint*) for the referenced pump relay.

The setpoint is scaled from 0 to 10,000 (0 to 100% of span multiplied by 100). So 54.02% is shown in the register as 5402.

Pump OFF setpoint (R41,430 – R41,435)

The OFF setpoint level (2.8.1.6. *OFF Setpoint*) for the referenced pump relay.

The setpoint is scaled from 0 to 10,000 (0 to 100% of span multiplied by 100). So 54.02% is shown in the register as 5402.

Pumped volume (R41,440 – R41,443)

The pumped volume registers hold the current total for all of the pumps associated with a level point. These registers are available only if operation is set to **pumped volume** (2.1.3. *Sensor Mode* = Pump Totalizer).

These volumes can become very large. Therefore, two registers are used to hold the value. See *Unsigned double precision integer (UINT32) on page 268* for more information.

The value in the registers is given as an integer value but must be interpreted as having the number of decimals set in 2.14.4. *Totalizer Decimal Position*. this number can be 0 to 3.

Ensure that your software accounts for these decimal places before you report the pumped volume totals.

Pump hours (R41,450 – R41,461)

The number of running hours for the referenced pump relay. The hours are given to three decimal places, so the integer must be divided by 1000 to get the correct value. For example 12,340 represents 12.34 hours.

This value comes from parameter 3.2.7.2. *Pump Hours*. See page 190 for details.

Pump starts (R41,470 – R41,475)

The number of pump starts for the referenced pump relay.

This value comes from parameter 3.2.7.4. *Pump Starts*. See page 190 for details.

Parameter access (R43,998 – R46,999)

Parameter values are given as integers in the range of registers from R44,000 to R44,999. The last three numbers of the register correspond to the parameter number.

Parameter Register #	Format Register #	Parameter
44,000	46,000	5.1. <i>Write Protection</i>
44,001	46,001	2.1.3. <i>Sensor Mode</i>
44,002	46002	2.1.6. <i>Material</i>
...
44,999	46,999	3.2.1. <i>Master Reset</i>

Usually, the parameters are all **read / write**.

Note:

- Parameters 5.1. *Write Protection* and 3.2.1. *Master Reset* are **Read only**.
- Parameter 3.2.1. *Master Reset* cannot be used via Modbus.
- See *Data types on page 268* for a description of the types associated with different parameters.

Each parameter register has a corresponding format register that holds the format information required to interpret the value. See *Format words (R46,000 to R46,999) on page 266*.

Parameter indexing

Many parameters are indexed. There are two possible indexes: a primary index and a secondary index. A secondary index is a sub-address of the primary index. Some indexed parameters affect multiple I/O devices.

The following is an example of a primary index:

2.8.1.4. Relay Function is the Relay Control Function. This parameter determines how a relay is controlled by the HydroRanger 200 HMI (used as an alarm, for pump control, etc.). Because there are up to six relays on the HydroRanger 200 HMI, *2.8.1.4. Relay Function* is indexed by six to allow each relay to be programmed independently.

A few parameters also have a secondary index. While a secondary index is important for setting up the HydroRanger 200 HMI, it is almost never needed through remote communications.

Indexing the parameter access area

Each parameter communicates its value to only one register. You must know the index(es) for the parameter in order to interpret the information in the register correctly.

For example, to make use of the value returned in register R44,111 you must know which relay it is referring to. See *Relay function codes (2.8.1.4. Relay Function Only)* on page 271 for details on *2.8.1.4. Relay Function* values.

To determine the index values, the primary and secondary index must be **read** or **write**. The two possible methods of handling these index values are described in *Global index method* and *Parameter-specific index method*, below.

Reading parameters

To read parameter values, follow the steps listed in either the Global or the Parameter-specific index methods that follow. You must be able to program your HMI or SCADA system before completing these methods.

Global index method

Set *4.11. Parameter Index Location* = Global.

Global format method sets index values for all parameters simultaneously. Use this method to read multiple values set to the same index values.

1. Write the primary index value into R43,999.

This is a value between **0** and **40** which specifies the input or output indexed by the parameter.

Examples are:

- Transducer 1 is Index 1.
- Discrete input 2 is Index 2.
- Relay 5 is Index 5.

2. Write the secondary index value into R43,998.

This is a value between **0** and **40** that specifies the secondary index on the parameter. This value is usually **0**.

3. Write the desired format value into the appropriate format register. Because the primary and secondary indexes are already specified, these portions of the format word are ignored and only the last digit is significant.
See *Format registers on page 266* for details.
4. Read the value from the appropriate parameter register.

Types of values are:

- *Numeric values on page 268*
- *Bit values on page 268*
- *Split values on page 269*
- *Text messages on page 270*
- *Relay function codes (2.8.1.4. Relay Function Only) on page 271*

A value of 22,222 indicates that an error has occurred. Specify a different format type and try again.

Parameter-specific index method

Set 4.11. *Parameter Index Location* = Parameter-specific.

The Parameter-specific index method sets the index values for each parameter independently. Use this method to read multiple parameters with different index values.

1. Write the primary index, secondary index, and data format values into the appropriate format register.

For example, send the integer value 01008 to register 46,921, in order to read the following information:

- Measured level (*3.2.6.3. Level*).
- In units with three decimal places.
- From Transducer 1.

2. Read the value from the appropriate parameter register (the example uses 44,921).

Types of values are:

- *Numeric values on page 268*
- *Bit values on page 268*
- *Split values on page 269*
- *Text messages on page 270*
- *Relay function codes (2.8.1.4. Relay Function Only) on page 271*

A value of 22,222 indicates that an error occurred. Specify a different format type and try again.

Writing parameters

The method of writing parameters is similar to the method of reading them. Become familiar with *Reading parameters on page 264* before attempting to write any.

To write parameter values to the HydroRanger 200 HMI, follow these steps:

Global index method

Set 4.11. *Parameter Index Location* = *Global.

1. Write the primary index value into R43,999.
2. Write the secondary index value into R43,998.
3. Write the desired format value into the appropriate format register.
4. Write the value to the appropriate parameter register.

Parameter-specific index method

Set 4.11. *Parameter Index Location* = *Parameter-specific*.

1. Write the primary index, secondary index, and data format values into the appropriate format register.
2. Write the value to the appropriate parameter register.

Format words (R46,000 to R46,999)

Format words are unsigned integers that contain up to three values (described below). The number of values used in the format words depends on the *4.11. Parameter Index Location* that is used.

4.11. Parameter Index Location, described on page 197, determines which of two methods is used to access the format words: Global Index Method or Parameter-specific Index Method.

Global index method

Set 4.11. *Parameter Index Location* = *Global.

Only the final digit of the format word determines the decimal offset (below).

Parameter-specific index method

Set 4.11. *Parameter Index Location* = *Parameter-specific*.

All three decimal fields are used to determine the parameter value's primary index, secondary index, and decimal offset.

Format registers

Each format register is made up of three decimal fields:

- Decimal offset
- Secondary index
- Primary index

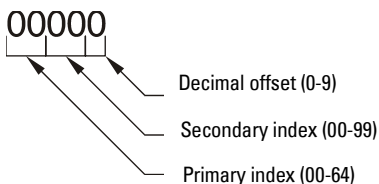

The primary and secondary indexes correspond to those that are used by the parameter.

The decimal offset indicates how the remote system must interpret the integer value that is stored in the parameter access register. The following table shows how different parameter values can be shown based on a register value (integer) of **1234**.

Decimal	Offset	Example
0	0	1,234
1	-1	12,340
2	-2	123,400
3	-3	1,234,000
4	-4	12,340,000
5	-5	123,400,000
6	+1	123.4
7	+2	12.34
8	+3	1.234
9	Percent	12.34%

Examples of using the format word for both the index values and the decimal offset value are shown below:

Format	Primary index	Secondary index	Decimal
00000	00	00	0
01003	01	00	3 right
02038	02	03	3 left
05159	05	15	Percent

To write these values you can use a decimal offset as follows: format word = (primary index x 1000) + (secondary index x 10) + (decimal).

Data types

The HydroRanger 200 HMI parameters do not always use integers to hold values. For the convenience of the programmer, those values are converted to and from a 16-bit integer number. This section describes the conversion process. The sections that follow describe where those values are in the discrete I/O and block transfer addresses, and how to get the parameters you need.

Numeric values

Numeric parameter values are the most common. For example, parameter *3.2.6.2 Reading* returns a number that represents the current reading (either **Level** or **Volume**, depending on the HydroRanger 200 HMI configuration).

Numeric values are requested or set in units or percent of span, and may be specified with a number of decimal places.

Numeric values must be in the range $-20,000$ to $+20,000$ to be valid. If a parameter is requested and its value is more than $+20,000$, the number *32,767* is returned; if it is less than $-20,000$, the number $-32,768$ is returned. If this overflow happens, decrease the number of decimal places.

If a parameter cannot be expressed in terms of percent of **Span**, or has no meaningful value, the number *22,222* is returned. Try requesting the parameter in units, or refer to *2.1.1. Units* on page 116.

Bit values

Bits are packed into registers in groups of 16 bits (1 word). In this manual, the bits are numbered from 1 to 16, with bit 1 as the least significant bit (LSB) and bit 16 as the most significant bit (MSB).

16	15	14	13	12	11	10	09	08	07	06	05	04	03	02	01
MSB															LSB

Unsigned double precision integer (UINT32)

Large numbers are put into unsigned 32-bit integers. By default, they are set up so that the first word (register) is the most significant word (MSW) and the second word (register) is the least significant word (LSW).

For example, if R41,442 is read as a UINT32, the 32 bits would look like this:

R41,442			R41,443		
16	MSW	1	16	LSW	1
32	32-bit integer value (UINT32)				1

The two registers are read as a 32-bit integer.

The most significant word (MSW) and least significant word (LSW) can be reversed to accommodate some Modbus drivers. See *Word order (R40,062) on page 260* for details.

The position of the decimal place is dependent on the register. For more details, see the description of the register.

Split values

Certain parameters are actually pairs of numbers separated by a colon, using this format: **xx:yy**.

One example is Echo Confidence as shown in Measurement View 2 (The LCD Display on page 25), where:

xx = the average noise value in dB

yy = the peak noise in dB

The number which corresponds to **xx:yy**, either for reading or setting a parameter, is determined by the following formula:

For storing to the device:

$$\text{value} = (\mathbf{xx} + 128) \times 256 + (\mathbf{yy} + 128)$$

For reading from the device:

$$\mathbf{xx} = (\text{value} / 256) - 128$$

$$\mathbf{yy} = (\text{value} \% 256) - 128$$

where % is the modulus operator.

The modulus can be computed by following these steps:

$$\text{value}_1 = \text{value} / 256$$

$$\text{value}_2 = \text{remainder of value}_1$$

$$\text{value}_3 = \text{value}_2 \times 256$$

$$\mathbf{yy} = \text{value}_3 - 128$$

It may simplify parameter to notice:

$$\mathbf{xx} = (\text{most significant byte of value}) - 128$$

$$\mathbf{yy} = (\text{least significant byte of value}) - 128$$

Text messages

If a device parameter returns a text message, that message is converted to an integer and provided in the register. The numbers are shown in the following table.

Number	Text message
22222	Invalid value
30000	OFF
30001	ON
30002	Parameter values of multiple points do not match.
30003	Parameter does not exist.
30004	ERR
30005	ERR1
30006	OPEN
30007	SHORT
30008	PASS
30009	FAIL
30010	HOLD
30011	LO
30012	HI
30013	DE
30014	EN
30015	Parameter has not been set.
-32768	Value is less than -20,000
32767	Value is greater than 20,000

Relay function codes (2.8.1.4. Relay Function Only)

Please note that the HydroRanger 200 HMI offers more function codes.

If a device parameter returns a relay function code, that message is converted to a number and is then provided in the register. The numbers are shown in the following table:

Control	Relay function code	Number	2.8.1.4. Relay Function
General	OFF, relay not used	0	*OFF
	Undesignated Level Alarm	1	Level
	Lo-Lo Level Alarm	2	Level – LL
	Low Level Alarm	3	Level – L
	High Level Alarm	4	Level – H
	Hi-Hi Level Alarm	5	Level – HH
	In-bounds Alarm	6	In-bounds
	Out-of-bounds Alarm	9	Out-of-bounds
	Rate of Level Change Alarm	12	Rate of Change
	Temperature Alarm	15	Temperature
	Loss of Echo (LOE) Alarm	20	LOE
	Transducer Cable Fault Alarm	16	Cable Fault
Flow	Totalizer	22	Totalizer
	Flow Sampler	23	Flow Sampler
Pump	Fixed Duty Assist	25	Fixed Duty Assist
	Fixed Duty Backup	26	Fixed Duty Backup
	Alternate Duty Assist	30	Alternate Duty Assist
	Alternate Duty Backup	31	Alternate Duty Backup
	Service Ratio Duty Assist	35	Service Ratio Duty Assist
	Service Ratio Duty Backup	36	Service Ratio Duty Backup
Control	First In First Out (FIFO)	40	First In First Out
	Flush Valve	65	Flush Valve
	Communication	66	Communication

See 2.8.1.4. Relay Function on page 141.

Error handling

Modbus responses

When polled by a Modbus Master, a slave device will do one of the following:

1. Not reply. This means that something went wrong with the transmission of the message.
2. Echo back the command with the correct response (see the Modbus specification for more details). This is the normal response.
3. Return an Exception Code. This reflects an error in the message.

HydroRanger 200 HMI uses the following exception codes:

Code	Name	Meaning
01	Illegal Function	The function code received in the query is not an allowable action for the slave.
02	Illegal Data Address	The data address received in the query is not an allowable address for the slave.
03	Illegal Data Value	A value contained in the query data field is not an allowable value for the slave.

Error handling

Errors can be traced to two general sources:

1. There is an error in transmission.

OR

2. The host tries to do something that is not a valid action.

In the first case, the HydroRanger 200 HMI does not respond and the master waits for a **response time out** error, which causes the master to re-send the message.

In the second case, the response depends on what the host tries to do. In general, HydroRanger 200 HMI will not give an error to the host request. Various actions and the expected outcome are as follows:

- If the host reads an invalid register, the host will get an undetermined value back.
- If the host writes an invalid register (a non-existing parameter or a **read only** parameter), the value will be ignored and no error response will be made. However, the current value will not reflect the desired new value.
- If the host writes a **read only** register, then the value will be ignored and no error response will be made. However, the current value will not reflect the desired new value.
- If *5.1. Write Protection* is activated, then the value will be ignored and no error response will be made. However, the current value will not reflect the desired new value.
- If the host attempts to write one or more registers that are out of range, an exception code **02** or **03** is generated, depending if the start address is valid.
- If the host used an unsupported function code, an exception code of **01** should be generated. However, this is not guaranteed and there may be no response.

Communication troubleshooting

General

1. Check the following:
 - There is power in the unit.
 - The LCD is showing the relevant data.
2. Check the wiring pin outs and verify that the connection is correct.
3. Verify that the settings in the computer used to communicate with the unit match the values in the set-up parameters listed below:

Parameter

4.4. Protocol

4.2. Device Address

4.5. Serial Baud Rate

4.6. Parity

4.7. Data Bits

4.8. Stop Bits

4.9. Modem Available

4.10. Modem Inactivity Timeout

4. Check that the port on the computer is correct. Sometimes, trying a different Modbus driver will solve the problem.

Specific

1. The HydroRanger 200 HMI is set to communicate via a modem but no communication is returning to the master.
 - Check that the parameters are set up correctly and that the correct port is configured
 - Verify the wiring diagram. Note that there is a difference between wiring directly to a computer and wiring to a modem.
 - Verify that the modem is set up correctly. Siemens has a series of application guides that may help. Please contact your local Siemens representative for more information on application guides.
2. A HydroRanger 200 HMI parameter is set via remote communications, but the parameter remains unchanged.
 - Some parameters can only be changed when the device is not scanning. Try putting the device in PROGRAM mode, using the operating mode function.
 - Try setting the parameter from the keypad. If it can not be set using the keypad, check *5.1. Write Protection* and set it to **1954**.

Single Parameter Access (SPA)

This section is intended to provide someone with advanced communications knowledge the ability to access any parameter value in any available format.

Built in to HydroRanger 200 HMI is an advanced handshaking area that can be used to read and write single registers to the HydroRanger 200 HMI. This section performs a similar function to the Parameter access section. The differences are:

1. Advanced section is more powerful and harder to program.
2. Advanced section only gives you access to one parameter at a time.

Mapping

Parameter Read and Write (40,090 – 40,097) is a series of eight registers used for reading and writing parameter values to and from the HydroRanger 200 HMI. The first three registers are always unsigned integers representing parameters and index values. The second five registers are the format and value(s) of the parameter.

Address	Description
40,090	Parameter (integer)
40,091	Primary index (integer)
40,092	Secondary index (integer)
40,093	Format word (bit mapped)
40,094	Read value, word 1
40,095	Read value, word 2
40,096	Write value, word 1
40,097	Write value, word 2

Reading parameters

To read parameters through Modbus, do the following steps:

1. Send the parameter, its primary index, and its secondary index (usually 0), and format to registers 40,090 to 40,093.
2. Wait until you can read the written values from the registers (40,090 to 40,093) to confirm that the operation is complete.
3. Read the value from registers 40,094 and 40,095.

Writing parameters

To set parameters through Modbus, do the following steps:

1. Send the parameter, its primary index, and its secondary index (usually **0**) to registers 40,090, 40,091, and 40,092.
2. Write the value to registers 40,096 and 40,097.
3. Write the desired format word to register 40,093 to enable the HydroRanger 200 HMI to interpret the value correctly.

Format register

Bits	Values	Description
1-8	0-2	Error Code
9-11	0-7	3-bit number representing decimal offset
12	0/1	Direction of offset (0 = right, 1 = left)
13	0/1	Numeric format: Fixed (0) or Float (1)
14	0/1	Read or Write of data, Read (0), Write (1)
15	0/1	Word order: Most Significant Word first (0), Least Significant Word first (1)
16		Reserved

For example, to format the level reading so that it is shown in percent with two decimal places shifted left, the format bits would look like this:

Bit numbers	16	15	14	13	12	11	10	09	08	07	06	05	04	03	02	01
Bit values	0	0	0	0	0	0	1	0	0	0	0	0	0	0	0	0
	Reserved	Most significant first	Read	Fixed format	Offset direction to right	Decimal offset of 2			No error code							

The value sent to the HydroRanger 200 HMI is 0001001000000000 binary or 512 decimal. The value **512** is sent as an integer to register 40,093 to format the output words 40,094 and 40,095 accordingly.

If the numeric data type is set for integer and the value contains decimal places, they are ignored. In this situation, use the decimal offset to ensure that you have an integer value and then write your code to recognize and handle the decimal offset.

Error codes

The error codes returned in the format area are 8-bit integers found in the lowest eight bits of the format word. This allows for 256 potential error codes.

Currently, the HydroRanger 200 HMI has two error codes available.

Values	Description
0	No error
1	Data not available as percent (available as units).
2-255	Reserved

Appendix D: Updating software

Please contact your Siemens representative to obtain the software update for the HydroRanger 200 HMI. A complete list of representatives is available here: www.siemens.com/processinstrumentation, and choose Service on the right side.

WARNINGS:

- 1. All parameter values will be lost during software update. Record your current parameters manually or using SIMATIC PDM before updating.**
- 2. Disable all pumps and alarms before updating software, as relays can change state during the procedure, causing pumps to turn ON or OFF.**

To install the software, please complete the following:

1. Connect your PC or laptop to the HydroRanger's RJ-11 RS-232 port.
2. Run the **.exe Downloader** program in the software. Use this to make the RS-232 settings match your HydroRanger 200 HMI. Please note that the software default settings will already match the default settings of the unit. Changes are only necessary if the RS-232 settings in the unit have been changed.
3. Complete the **Downloader** program steps.
4. Verify that **Downloader** confirms a successful upgrade before exiting.
5. Complete a master reset (*3.2.1. Master Reset* on page 186) after a successful upgrade before re-entering parameters.

Appendix E: Upgrading

The following procedure will assist you if you are upgrading from a MultiRanger Plus or HydroRanger 200 to a HydroRanger 200 HMI.

If the application is unchanged, copy the parameters in the MultiRanger Plus or HydroRanger 200 before de-commissioning the unit.

Mounting a HydroRanger 200 HMI

Please read the section on *Installing and mounting* on page 8, then follow these steps:

1. Turn OFF the MultiRanger Plus or HydroRanger 200.
2. Disconnect and label all cables from the terminal blocks.
3. Remove the enclosure from the wall and pull all cables through the conduit entries.
4. Install the new HydroRanger 200 HMI on the same mounting holes used by the MultiRanger Plus or HydroRanger 200.
5. Feed all cables through the conduit entries.
6. Connect all cables to the appropriate terminal block on HydroRanger 200 HMI.

Connecting the transducer

Important: Unlike in the MultiRanger Plus, co-axial cable is not recommended for use with the HydroRanger 200 HMI for transducer cable extensions. The HydroRanger 200 HMI circuit is designed to use shielded twisted pair cable. Ideally, the co-axial cable should be replaced with twisted pair.

If this is not practical, please refer to the section below.

Co-axial transducer extension

The HydroRanger 200 HMI uses a differential input receiver that works either directly connected to the transducer lead, or with a screened twisted pair extension cable via a field junction box. This arrangement, using two conductors and a screen, gives considerably better electrical noise immunity than the previous co-axial arrangement (up to 20 dB). It gives a more reliable operation in applications where the proximity of power cables, variable speed drives, etc. would have caused problems.

If you are installing a new HydroRanger 200 HMI system and an extension is required, we strongly recommend that you use a good quality screened, twisted pair cable. If the integral transducer cable is used, you only need to connect the HydroRanger 200 HMI and benefit from its superior performance.

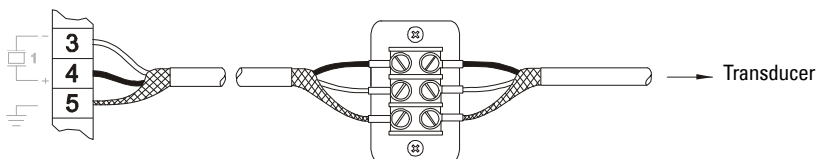

Connecting a transducer with RG62 co-axial extension cable

If you are replacing an older Siemens Milltronics Ultrasonic Level Controller with a new HydroRanger 200 HMI where an RG62 co-axial extension is fitted, and you are unable to replace the extension with a new cable, please refer to the connection diagram below. Please note that the noise immunity performance will be similar to our older model ultrasonic level controllers if you use a co-axial cable.

Existing installation

RG62 co-axial cable has been used to make the extension. The level controller might be a MultiRanger Plus, HydroRanger, HydroRanger Plus or our other similar devices.

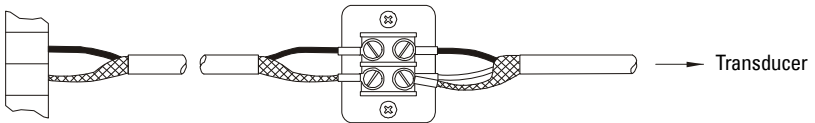

HydroRanger 200 HMI Installation (for retrofitting MultiRanger Plus installations)

Connect with a $0.1\mu\text{F}$ (100 V or greater) capacitor (included with HydroRanger 200 HMI) between the shield and negative terminals. Connect the center core of the co-axial to the positive terminal, and the screen to the negative terminal.

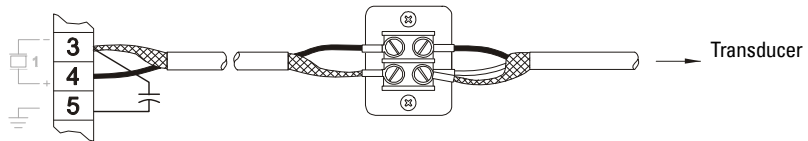

Appendix F: Conduit Entry for Class I, Div 2 Applications

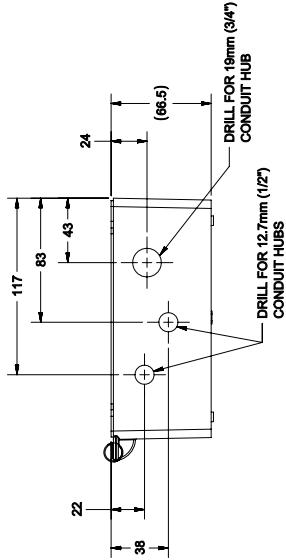
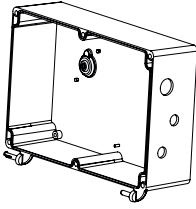
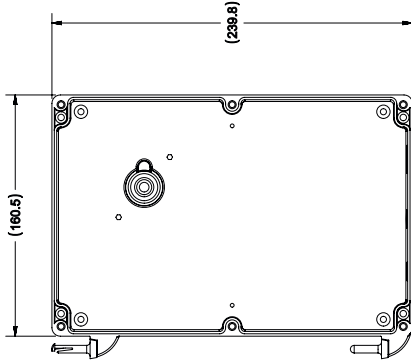

NOTES:

- 1) USE ONLY CONDUIT HUBS CERTIFIED/APPROVED AS TYPE 4X.
- 2) NON METALLIC ENCLOSURE DOES NOT PROVIDE GROUNDING BETWEEN CONDUIT CONNECTIONS. USE GROUNDING TYPE BUSHINGS AND JUMPER WIRES.
- WARNING: EXPLOSION HAZARD - SUBSTITUTION OF COMPONENTS MAY IMPAIR SUITABILITY FOR CLASS 1, DIVISION 2.**
- WARNING: EXPLOSION HAZARD - DO NOT REPLACE BATTERY UNLESS POWER HAS BEEN DISCONNECTED. NON-HAZARDOUS.**
- WARNING: EXPLOSION HAZARD - DO NOT PERFORM SERVICING UNLESS AREA IS KNOWN TO BE NON-HAZARDOUS.**
- WARNING: EXPLOSION HAZARD - DO NOT DISCONNECT TERMINAL CONNECTORS WHILE CIRCUIT IS LIVE UNLESS AREA IS KNOWN TO BE NON-HAZARDOUS.**

DIMENSIONS ARE IN MILLIMETERS

Part No.	6X9 VENTED ENCL. FOR CLASS 1, DIV 2
Material	PKRLE
Weight	0.8 kg
Volume	0.01 m ³
Manufacturer	PKRLE
Customer	205-59-94 Pkile
Approved	
Approved 1	U.A. SZ. PZ. RD. REC. ENG.
Drawn By	
Part No.	45 AA
Material	001
Manufacturer	ASE35806240A
Customer	
Approved	
Approved 1	
Drawn By	
Part No.	001
Material	001
Manufacturer	ASE35806240A
Customer	
Approved	
Approved 1	
Drawn By	
Part No.	001
Material	001
Manufacturer	ASE35806240A
Customer	
Approved	
Approved 1	
Drawn By	
Part No.	001
Material	001
Manufacturer	ASE35806240A
Customer	
Approved	
Approved 1	
Drawn By	
Part No.	001
Material	001
Manufacturer	ASE35806240A
Customer	
Approved	
Approved 1	
Drawn By	
Part No.	001
Material	001
Manufacturer	ASE35806240A
Customer	
Approved	
Approved 1	
Drawn By	
Part No.	001
Material	001
Manufacturer	ASE35806240A
Customer	
Approved	
Approved 1	
Drawn By	
Part No.	001
Material	001
Manufacturer	ASE35806240A
Customer	
Approved	
Approved 1	
Drawn By	
Part No.	001
Material	001
Manufacturer	ASE35806240A
Customer	
Approved	
Approved 1	
Drawn By	
Part No.	001
Material	001
Manufacturer	ASE35806240A
Customer	
Approved	
Approved 1	
Drawn By	
Part No.	001
Material	001
Manufacturer	ASE35806240A
Customer	
Approved	
Approved 1	
Drawn By	
Part No.	001
Material	001
Manufacturer	ASE35806240A
Customer	
Approved	
Approved 1	
Drawn By	
Part No.	001
Material	001
Manufacturer	ASE35806240A
Customer	
Approved	
Approved 1	
Drawn By	
Part No.	001
Material	001
Manufacturer	ASE35806240A
Customer	
Approved	
Approved 1	
Drawn By	
Part No.	001
Material	001
Manufacturer	ASE35806240A
Customer	
Approved	
Approved 1	
Drawn By	
Part No.	001
Material	001
Manufacturer	ASE35806240A
Customer	
Approved	
Approved 1	
Drawn By	
Part No.	001
Material	001
Manufacturer	ASE35806240A
Customer	
Approved	
Approved 1	
Drawn By	
Part No.	001
Material	001
Manufacturer	ASE35806240A
Customer	
Approved	
Approved 1	
Drawn By	
Part No.	001
Material	001
Manufacturer	ASE35806240A
Customer	
Approved	
Approved 1	
Drawn By	
Part No.	001
Material	001
Manufacturer	ASE35806240A
Customer	
Approved	
Approved 1	
Drawn By	
Part No.	001
Material	001
Manufacturer	ASE35806240A
Customer	
Approved	
Approved 1	
Drawn By	
Part No.	001
Material	001
Manufacturer	ASE35806240A
Customer	
Approved	
Approved 1	
Drawn By	
Part No.	001
Material	001
Manufacturer	ASE35806240A
Customer	
Approved	
Approved 1	
Drawn By	
Part No.	001
Material	001
Manufacturer	ASE35806240A
Customer	
Approved	
Approved 1	
Drawn By	
Part No.	001
Material	001
Manufacturer	ASE35806240A
Customer	
Approved	
Approved 1	
Drawn By	
Part No.	001
Material	001
Manufacturer	ASE35806240A
Customer	
Approved	
Approved 1	
Drawn By	
Part No.	001
Material	001
Manufacturer	ASE35806240A
Customer	
Approved	
Approved 1	
Drawn By	
Part No.	001
Material	001
Manufacturer	ASE35806240A
Customer	
Approved	
Approved 1	
Drawn By	
Part No.	001
Material	001
Manufacturer	ASE35806240A
Customer	
Approved	
Approved 1	
Drawn By	
Part No.	001
Material	001
Manufacturer	ASE35806240A
Customer	
Approved	
Approved 1	
Drawn By	
Part No.	001
Material	001
Manufacturer	ASE35806240A
Customer	
Approved	
Approved 1	
Drawn By	
Part No.	001
Material	001
Manufacturer	ASE35806240A
Customer	
Approved	
Approved 1	
Drawn By	
Part No.	001
Material	001
Manufacturer	ASE35806240A
Customer	
Approved	
Approved 1	
Drawn By	
Part No.	001
Material	001
Manufacturer	ASE35806240A
Customer	
Approved	
Approved 1	
Drawn By	
Part No.	001
Material	001
Manufacturer	ASE35806240A
Customer	
Approved	
Approved 1	
Drawn By	
Part No.	001
Material	001
Manufacturer	ASE35806240A
Customer	
Approved	
Approved 1	
Drawn By	
Part No.	001
Material	001
Manufacturer	ASE35806240A
Customer	
Approved	
Approved 1	
Drawn By	
Part No.	001
Material	001
Manufacturer	ASE35806240A
Customer	
Approved	
Approved 1	
Drawn By	
Part No.	001
Material	001
Manufacturer	ASE35806240A
Customer	
Approved	
Approved 1	
Drawn By	
Part No.	001
Material	001
Manufacturer	ASE35806240A
Customer	
Approved	
Approved 1	
Drawn By	
Part No.	001
Material	001
Manufacturer	ASE35806240A
Customer	
Approved	
Approved 1	
Drawn By	
Part No.	001
Material	001
Manufacturer	ASE35806240A
Customer	
Approved	
Approved 1	
Drawn By	
Part No.	001
Material	001
Manufacturer	ASE35806240A
Customer	
Approved	
Approved 1	
Drawn By	
Part No.	001
Material	001
Manufacturer	ASE35806240A
Customer	
Approved	
Approved 1	
Drawn By	
Part No.	001
Material	001
Manufacturer	ASE35806240A
Customer	
Approved	
Approved 1	
Drawn By	
Part No.	001
Material	001
Manufacturer	ASE35806240A
Customer	
Approved	
Approved 1	
Drawn By	
Part No.	001
Material	001
Manufacturer	ASE35806240A
Customer	
Approved	
Approved 1	
Drawn By	
Part No.	001
Material	001
Manufacturer	ASE35806240A
Customer	
Approved	
Approved 1	
Drawn By	
Part No.	001
Material	001
Manufacturer	ASE35806240A
Customer	
Approved	
Approved 1	
Drawn By	
Part No.	001
Material	001
Manufacturer	ASE35806240A
Customer	
Approved	
Approved 1	
Drawn By	
Part No.	001
Material	001
Manufacturer	ASE35806240A
Customer	
Approved	
Approved 1	
Drawn By	
Part No.	001
Material	001
Manufacturer	ASE35806240A
Customer	
Approved	
Approved 1	
Drawn By	
Part No.	001
Material	001
Manufacturer	ASE35806240A
Customer	
Approved	
Approved 1	
Drawn By	
Part No.	001
Material	001
Manufacturer	ASE35806240A
Customer	
Approved	
Approved 1	
Drawn By	
Part No.	001
Material	001
Manufacturer	ASE35806240A
Customer	
Approved	
Approved 1	
Drawn By	
Part No.	001
Material	001
Manufacturer	ASE35806240A
Customer	
Approved	
Approved 1	
Drawn By	
Part No.	001
Material	001
Manufacturer	ASE35806240A
Customer	
Approved	
Approved 1	
Drawn By	
Part No.	001
Material	001
Manufacturer	ASE35806240A
Customer	
Approved	
Approved 1	
Drawn By	
Part No.	001
Material	001
Manufacturer	ASE35806240A
Customer	
Approved	
Approved 1	
Drawn By	
Part No.	001
Material	001
Manufacturer	ASE35806240A
Customer	
Approved	
Approved 1	
Drawn By	
Part No.	001
Material	001
Manufacturer	ASE35806240A
Customer	
Approved	
Approved 1	
Drawn By	
Part No.	001
Material	001
Manufacturer	ASE35806240A
Customer	
Approved	
Approved 1	
Drawn By	
Part No.	001
Material	001
Manufacturer	ASE35806240A
Customer	
Approved	
Approved 1	
Drawn By	
Part No.	001
Material	001
Manufacturer	ASE35806240A
Customer	
Approved	
Approved 1	
Drawn By	
Part No.	001
Material	001
Manufacturer	ASE35806240A
Customer	
Approved	
Approved 1	
Drawn By	
Part No.	001
Material	001
Manufacturer	ASE35806240A
Customer	
Approved	
Approved 1	
Drawn By	
Part No.	001
Material	001
Manufacturer	ASE35806240A
Customer	
Approved	
Approved 1	
Drawn By	
Part No.	001
Material	001
Manufacturer	ASE35806240A
Customer	
Approved	
Approved 1	
Drawn By	
Part No.	001
Material	001
Manufacturer	ASE35806240A
Customer	
Approved	
Approved 1	
Drawn By	
Part No.	001
Material	001
Manufacturer	ASE35806240A
Customer	
Approved	
Approved 1	
Drawn By	
Part No.	001
Material	001
Manufacturer	ASE35806240A
Customer	
Approved	
Approved 1	
Drawn By	
Part No.	001
Material	001
Manufacturer	ASE35806240A
Customer	
Approved	
Approved 1	
Drawn By	
Part No.	0

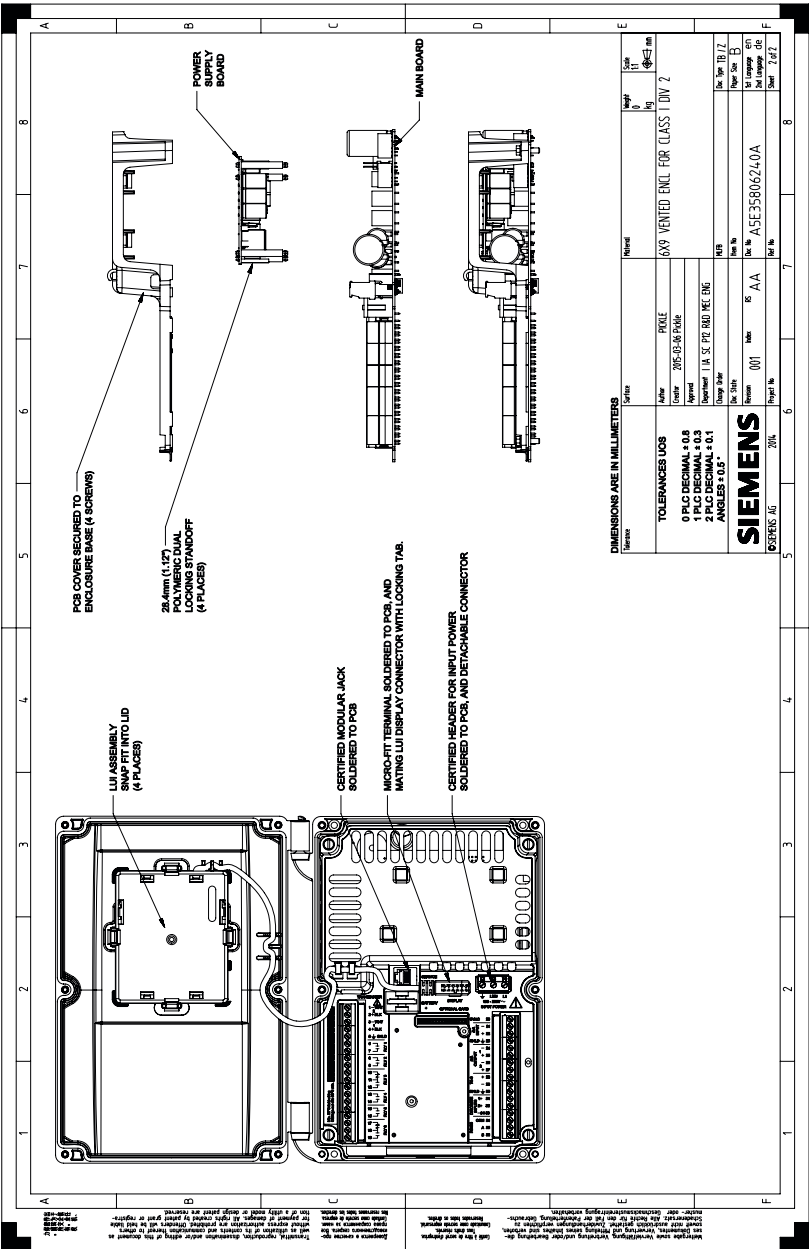

DIMENSIONS ARE IN MILLIMETERS

Material	Color	Temp	Code
ROKLE	RAL 7035	0	0825
6X9 VENTED ENC FOR CLASS DIV 2			
Address	ROKLE		
Order	205-55-86-040A		
Approved			
Approved by	1.1A, S1, P12, R03, KEE, ENG		
Design Date		Doc. Type	TR / Z
Doc. Status		Rev. No.	05
Revision	001	Rev. Date	15
Part No.	AA	1st Issuance	01
Project No.	AA	2nd Issuance	01
Doc. No.	AA	3rd Issuance	01
Doc. Title	AA	Doc. No.	AA
Doc. No.	AA	Doc. Title	AA
Doc. Title	AA	Doc. No.	AA
Doc. Title	AA	Doc. No.	AA

SIEMENS

6ES7 306-1EA00-0AB0

Programming chart

Altered Values for Indices/Point Numbers			
Parameter	1	2	3
Security			
5.1. Write Protection			
5.2. User PIN			
Quickstart			
2.1.3. Sensor Mode			
2.1.6. Material			
2.3.4. Response Rate			
2.1.5. Transducer			
2.1.1. Units			
2.2.4. Empty			
2.2.2. Span			
Volume			
2.7.2. Vessel Shape			
2.7.3. Maximum Volume			
2.7.4. Dimension A			
2.7.5. Dimension L			
Reading Value			
2.12.4. Decimal Position			
2.12.5. Convert Reading			
2.12.6. Offset Reading			
2.9.1.2. Discrete Input Number			
2.9.1.3. Level Override Value			
2.9.1.4. Override Time Delay			
Fail-safe			
2.4.2. LOE Timer			
2.4.5. Material Level			
2.4.6. Fail-safe Advance			
Relays			
2.8.1.2. Level Source			
2.8.1.3. Preset Applications			
2.8.1.4. Relay Function			
2.8.1.5. ON Setpoint			
2.8.1.6. OFF Setpoint			
2.8.2.4. Relay Interval Setpoint			

Altered Values for Indices/Point Numbers			
Parameter	1	2	3
2.8.2.5. Relay Dead Band			
2.8.1.11. Relay Logic			
3.2.5. Relay Logic Test			
Pump Setpoint Modifiers			
2.8.1.8. Pump by Rate			
2.8.1.12. Service Ratio			
Independent Relay Fail-safe			
2.8.2.3. Relay Fail-safe			
Advanced Pump Control Modifiers			
2.8.2.7.1. Run-ON Interval			
2.8.2.7.3. Run-ON Duration			
2.8.2.8.1. Delay Between Starts			
2.8.2.8.2. Power Resumption Delay			
2.8.2.6.2. Level Setpoint Variation			
2.8.2.2. Pump Group			
Flush Systems			
2.10.3.2. Flush Pump			
2.10.3.3. Flush Cycles			
2.10.3.4. Flush Interval			
2.10.3.5. Flush Duration			
mA Output			
2.5.2. mA Output Range			
2.5.3. Current Output Function			
2.5.4. mA Output Allocation			
Independent mA Setpoints			
2.5.5. 4 mA Setpoint			
2.5.6. 20 mA Setpoint			
mA Output Limits			
2.5.7. Minimum mA Limit			
2.5.8. Maximum mA Limit			
mA Output Trim			
2.5.11. 4 mA Output Trim			
2.5.12. 20 mA Output Trim			
2.4.4. Fail-safe Mode			
mA Input			
2.6.1. mA Input Range			
2.6.2. 0/4 mA Level Value			

Altered Values for Indices/Point Numbers			
Parameter	1	2	3
2.6.3. 20 mA Level Value			
2.6.4. mA Damp Filter			
2.6.5. Scaled mA Input Value			
2.6.6. Raw mA Input Value			
Discrete Input Functions			
2.9.2.1. Discrete Input 1			
2.9.2.2. Discrete Input 2			
2.9.2.3. Discrete Input 1 Scaled State			
3.3.1.4. Discrete Input 2 Scaled State			
Record Temperatures			
3.2.8.2. Transducer Temperature Maximum			
3.2.8.3. Transducer Temperature Minimum			
3.2.8.4. TS-3 Temperature Maximum			
3.2.8.5. TS-3 Temperature Minimum			
Record Readings			
3.2.7. Pump Records			
3.2.6.9. Reading Minimum			
Pump Records			
3.2.7.3. Pump Run Time			
3.2.7.2. Pump Hours			
3.2.7.4. Pump Starts			
3.2.7.5. Pump Run-ONs			
Flow Records			
3.2.7. Pump Records			
3.2.6.16. Flow Minimum			
Installation Records			
3.1.9. Manufacture Date			
3.2.3. Power-ON Time			
3.2.2. Power-ON Resets			
Open Channel Monitoring			
2.13.2. Primary Measuring Device			
2.13.4.1. Flow Exponent			
2.13.5. PMD Dimensions			
2.13.4.2. Maximum Head			
2.13.4.3. Maximum Flow			
2.13.4.5. Zero Head			

Altered Values for Indices/Point Numbers

Parameter	1	2	3
2.13.4.4. Flow Time Units			
2.13.4.6. Flowrate Decimal			
2.13.4.7. Flowrate Units			
2.13.6.1.1. Head 1			
2.13.6.1.2. Flow 1			
2.13.4.8. Low Flow Cutoff			
2.13.3. Auto Zero Head			
Pumped Volume Totalizer			
2.7.7. Inflow/discharge Adjust			
Totalizer			
2.14.5. Totalizer Multiplier			
2.14.4. Totalizer Decimal Position			
2.10.1.2. Multiplier			
2.10.2.2. Mantissa			
2.10.2.3. Exponent			
2.10.2.4. Relay Duration			
Range Calibration			
2.2.5. Sensor Offset			
2.11.1.8. Auto Sound Velocity			
2.11.1.9. Offset Correction			
2.11.1.2. Sound Velocity			
2.11.1.7. Sound Velocity at 20°C			
Temperature Compensation			
2.11.1.4. Temperature Source			
2.11.1.6. Fixed Temperature			
2.11.1.5. Temperature Transducer Allocation			
2.11.1.3. Process Temperature			
Rate			
2.3.2. Fill Rate/minute			
2.3.3. Empty Rate/minute			
2.3.9. Filling Indicator			
2.3.10. Emptying Indicator			
2.3.5. Rate Filter			
2.3.6. Rate Filter Time			
2.3.7. Rate Filter Distance			
3.2.6.15. Flow Maximum			

Altered Values for Indices/Point Numbers

Parameter	1	2	3
3.2.7. Pump Records			
Measurement Verification			
2.11.5.6. Fuzz Filter			
2.11.5.4. Echo Lock			
2.11.5. Measurement Verification			
2.11.5.5. Echo Lock Window			
Transducer Scanning			
2.1.13. Shot Synchro			
2.1.14. Scan Delay			
2.1.16. Shot Delay			
2.1.15. Scan Time			
Display			
2.12.7. Default Auxiliary Reading			
2.12.8. Display Delay			
2.12.1. Local Display Backlight			
4.3. Communications Timeout			
SmartLinX® Reserved			
Communications			
4.2. Device Address			
4.4. Protocol			
4.5. Serial Baud Rate			
4.6. Parity			
4.7. Data Bits			
4.8. Stop Bits			
4.9. Modem Available			
4.10. Modem Inactivity Timeout			
4.11. Parameter Index Location			
SmartLinX® Hardware Testing			
3.2.10.1. Hardware Status			
3.2.10.2. Hardware Status Code			
3.2.10.3. Hardware Error Count			
3.2.10.4. Smartlinx® Module Type			
3.2.10.5. Smartlinx® Protocol			
5.4. Communications Control			
Echo Processing			
2.2.6. Blanking			
2.2.7. Range Extension			

Altered Values for Indices/Point Numbers

Parameter	1	2	3
2.11.2.8. Submergence Detection			
2.1.17. Shot/pulse Mode			
2.11.2.3. Long Echo Threshold			
3.2.9.2. Long Confidence			
3.2.9.4. Echo Strength			
Advanced Echo Processing			
3.2.9.7. Echo Time Filtered			
3.2.9.8. Echo Time Raw			
2.11.2.2. Algorithm			
2.11.2.7. Spike Filter			
2.11.2.6. Narrow Echo Filter			
2.11.2.5. Reform Echo			
2.11.2.9. Echo Marker			
Advanced TVT Adjustment			
2.11.3.6. TVT Type			
2.11.3.5. Shaper Mode			
2.11.4. TVT Shaper			
2.11.3.7. TVT dB			
2.11.3.8. TVT ms			
2.11.3.9. TVT Slope Minimum			
2.11.3.2. Auto False Echo Suppression			
2.11.3.3. Auto Suppression Range			
2.11.3.4. Hover Level			
Advanced Shot Adjustment			
2.1.11. Number of Short Shots			
2.1.12. Number of Long Shots			
2.1.7. Short Shot Frequency			
2.1.8. Long Shot Frequency			
2.1.10. Long Shot Duration			
2.1.9. Short Shot Duration			
2.11.2.10. Short Shot Bias			
2.11.2.11. Short Shot Floor			
2.11.2.12. Short Shot Range			
3.1.7. Firmware Revision			
2.5.9. Milliamp Output			
3.2.6.17. Transducer Temperature			
3.2.6.18. TS-3 Temperature			

Altered Values for Indices/Point Numbers			
Parameter	1	2	3
3.2.6.19. mA Input			
Measurement			
3.2.6.2. Reading			
3.2.6.3. Level			
3.2.6.11. Space			
3.2.6.12. Distance			
3.2.6.4. Distance (%)			
3.2.6.13. Head			
3.2.6.13. Head			
3.2.6.14. Flow			
3.2.1. Master Reset			

LCD Menu Structure

LCD Menu Structure



Notes:

- In Navigation mode **ARROW keys** navigate the menu in the direction of the arrow.
- See *Quick Start Wizards* on page 31 and *Parameters* on page 111 for detailed information and instructions.

MAIN MENU

1. WIZARDS

1.1. QUICK START

1.1.1. QS LEVEL

START OF QS LEVEL WIZARD
MEASUREMENT POINT SELECTOR*
TRANSDUCER
OPERATION
TEMPERATURE SOURCE
 FIXED TEMPERATURE
UNITS
EMPTY
SPAN
RESPONSE RATE
CONFIGURE ANOTHER MEASUREMENT POINT
END OF QS LEVEL WIZARD

1.1.2. QS VOLUME

START OF QS VOLUME WIZARD
MEASUREMENT POINT SELECTOR*
TRANSDUCER
OPERATION
TEMPERATURE SOURCE
 FIXED TEMPERATURE
VESSEL SHAPE
UNITS
EMPTY
SPAN
RESPONSE RATE
DIMENSION A**
DIMENSION L**
MAXIMUM VOLUME
CONFIGURE ANOTHER MEASUREMENT POINT
END OF QS VOLUME WIZARD

1.1.3. QS FLOW

START OF QS FLOW WIZARD
MEASUREMENT POINT SELECTOR*
TRANSDUCER
TEMPERATURE SOURCE
 FIXED TEMPERATURE
UNITS
EMPTY
SPAN
RESPONSE RATE

PRIMARY MEASURING DEVICE
FLOW EXPONENT***
FLOWRATE UNITS***
V-NOTCH ANGLE***
PMD DIMENSIONS***
MAXIMUM HEAD
ZERO HEAD
MAXIMUM FLOW
FLOWRATE DECIMAL
FLOW TIME UNITS
LOW FLOW CUTOFF
CONFIGURE ANOTHER MEASUREMENT POINT
END OF QS FLOW WIZARD

1.2. PUMP CONTROL

START OF QS PUMP CONTROL WIZARD
RELAY SELECTOR
RELAY FUNCTION
LEVEL SOURCE
SERVICE RATIO****
PUMP HOURS****
ON SETPOINT
OFF SETPOINT
CONFIGURE ANOTHER RELAY
END OF QS PUMP CONTROL WIZARD

2. SETUP

2.1. SENSOR

2.1.1. UNITS
2.1.2. LEVEL SELECTOR
2.1.3. SENSOR MODE
2.1.4. TRANSDUCER SELECTOR
2.1.5. TRANSDUCER
2.1.6. MATERIAL
2.1.7. SHORT SHOT FREQUENCY
2.1.8. LONG SHOT FREQUENCY
2.1.9. SHORT SHOT DURATION
2.1.10. LONG SHOT DURATION
2.1.11. NUMBER OF SHORT SHOTS
2.1.12. NUMBER OF LONG SHOTS
2.1.13. SHOT SYNCHRO
2.1.14. SCAN DELAY
2.1.15. SCAN TIME
2.1.16. SHOT DELAY
2.1.17. SHOT/PULSE MODE

2.2. CALIBRATION

2.2.1. LEVEL SELECTOR

- 2.2.2. SPAN
- 2.2.3. TRANSDUCER SELECTOR
- 2.2.4. EMPTY
- 2.2.5. SENSOR OFFSET
- 2.2.6. BLANKING
- 2.2.7. RANGE EXTENSION
- 2.3. RATE
 - 2.3.1. TRANSDUCER SELECTOR
 - 2.3.2. FILL RATE/MINUTE
 - 2.3.3. EMPTY RATE/MINUTE
 - 2.3.9. FILLING INDICATOR
 - 2.3.5. RATE FILTER
 - 2.3.6. RATE FILTER TIME
 - 2.3.7. RATE FILTER DISTANCE
 - 2.3.8. LEVEL SELECTOR
 - 2.3.9. FILLING INDICATOR
 - 2.3.10. EMPTYING INDICATOR
- 2.4. FAIL-SAFE
 - 2.4.1. TRANSDUCER SELECTOR
 - 2.4.2. LOE TIMER
 - 2.4.3. LEVEL SELECTOR
 - 2.4.4. FAIL-SAFE MODE
 - 2.4.5. MATERIAL LEVEL
 - 2.4.6. FAIL-SAFE ADVANCE
 - 2.4.7. mA OUTPUT SELECTOR
 - 2.4.8. mA FAIL-SAFE MODE
 - 2.4.9. mA FAIL-SAFE VALUE
- 2.5. CURRENT OUTPUT
 - 2.5.1. mA OUTPUT SELECTOR
 - 2.5.2. mA OUTPUT RANGE
 - 2.5.3. CURRENT OUTPUT FUNCTION
 - 2.5.4. mA OUTPUT ALLOCATION
 - 2.5.5. 4 mA SETPOINT
 - 2.5.6. 20 mA SETPOINT
 - 2.5.7. MINIMUM mA LIMIT
 - 2.5.8. MAXIMUM mA LIMIT
 - 2.5.9. MILLIAMP OUTPUT
 - 2.5.10. FAIL-SAFE MODE
 - 2.5.11. 4 mA OUTPUT TRIM
 - 2.5.12. 20 mA OUTPUT TRIM
- 2.6. CURRENT INPUT
 - 2.6.1. mA INPUT RANGE
 - 2.6.2. 0/4 mA LEVEL VALUE
 - 2.6.3. 20 mA LEVEL VALUE
 - 2.6.4. mA DAMP FILTER
 - 2.6.5. SCALED mA INPUT VALUE

- 2.6.6. RAW mA INPUT VALUE
- 2.7. VOLUME
 - 2.7.1. LEVEL SELECTOR
 - 2.7.2. VESSEL SHAPE
 - 2.7.3. MAXIMUM VOLUME
 - 2.7.4. DIMENSION A
 - 2.7.5. DIMENSION L
 - 2.7.6. TRANSDUCER SELECTOR
 - 2.7.7. INFLOW/DISCHARGE ADJUST
 - 2.7.8. TABLE 1-8
 - 2.7.8.1. LEVEL 1
 - 2.7.8.2. VOLUME 1
 - 2.7.8.3. LEVEL 2
 - 2.7.8.4. VOLUME 2
 - 2.7.8.5. LEVEL 3
 - 2.7.8.6. VOLUME 3
 - 2.7.8.7. LEVEL 4
 - 2.7.8.8. VOLUME 4
 - 2.7.8.9. LEVEL 5
 - 2.7.8.10. VOLUME 5
 - 2.7.8.11. LEVEL 6
 - 2.7.8.12. VOLUME 6
 - 2.7.8.13. LEVEL 7
 - 2.7.8.14. VOLUME 7
 - 2.7.8.15. LEVEL 8
 - 2.7.8.16. VOLUME 8
 - 2.7.9. TABLE 9-16
 - 2.7.9.1. LEVEL 9
 - 2.7.9.2. VOLUME 9
 - 2.7.9.3. LEVEL 10
 - 2.7.9.4. VOLUME 10
 - 2.7.9.5. LEVEL 11
 - 2.7.9.6. VOLUME 11
 - 2.7.9.7. LEVEL 12
 - 2.7.9.8. VOLUME 12
 - 2.7.9.9. LEVEL 13
 - 2.7.9.10. VOLUME 13
 - 2.7.9.11. LEVEL 14
 - 2.7.9.12. VOLUME 14
 - 2.7.9.13. LEVEL 15
 - 2.7.9.14. VOLUME 15
 - 2.7.9.15. LEVEL 16
 - 2.7.9.16. VOLUME 16
 - 2.7.10. TABLE 17-24
 - 2.7.10.1. LEVEL 17
 - 2.7.10.2. VOLUME 17
 - 2.7.10.3. LEVEL 18
 - 2.7.10.4. VOLUME 18
 - 2.7.10.5. LEVEL 19
 - 2.7.10.6. VOLUME 19
 - 2.7.10.7. LEVEL 20
 - 2.7.10.8. VOLUME 20
 - 2.7.10.9. LEVEL 21
 - 2.7.10.10. VOLUME 21
 - 2.7.10.11. LEVEL 22

- 2.7.10.12. VOLUME 22
- 2.7.10.13. LEVEL 23
- 2.7.10.14. VOLUME 23
- 2.7.10.15. LEVEL 24
- 2.7.10.16. VOLUME 24
- 2.7.11. TABLE 25- 32
 - 2.7.11.1. LEVEL 25
 - 2.7.11.2. VOLUME 25
 - 2.7.11.3. LEVEL 26
 - 2.7.11.4. VOLUME 26
 - 2.7.11.5. LEVEL 27
 - 2.7.11.6. VOLUME 27
 - 2.7.11.7. LEVEL 28
 - 2.7.11.8. VOLUME 28
 - 2.7.11.9. LEVEL 29
 - 2.7.11.10. VOLUME 29
 - 2.7.11.11. LEVEL 30
 - 2.7.11.12. VOLUME 30
 - 2.7.11.13. LEVEL 31
 - 2.7.11.14. VOLUME 31
 - 2.7.11.15. LEVEL 32
 - 2.7.11.16. VOLUME 32
- 2.8. RELAYS
 - 2.8.1. BASIC SETUP
 - 2.8.1.1. RELAY SELECTOR
 - 2.8.1.2. LEVEL SOURCE
 - 2.8.1.3. PRESET APPLICATIONS
 - 2.8.1.4. RELAY FUNCTION
 - 2.8.1.5. ON SETPOINT
 - 2.8.1.6. OFF SETPOINT
 - 2.8.1.7. LEVEL SELECTOR
 - 2.8.1.8. PUMP BY RATE
 - 2.8.1.9. FILLING INDICATOR
 - 2.8.1.10. EMPTYING INDICATOR
 - 2.8.1.11. RELAY LOGIC
 - 2.8.1.12. SERVICE RATIO
 - 2.8.2. MODIFIERS
 - 2.8.2.1. RELAY SELECTOR
 - 2.8.2.2. PUMP GROUP
 - 2.8.2.3. RELAY FAIL-SAFE
 - 2.8.2.4. RELAY INTERVAL SETPOINT
 - 2.8.2.5. RELAY DEAD BAND
 - 2.8.2.6. WALL CLING REDUCTION
 - 2.8.2.6.1. TRANSDUCER SELECTOR
 - 2.8.2.6.2. LEVEL SETPOINT VARIATION
 - 2.8.2.7. PUMP RUN-ON
 - 2.8.2.7.1. RUN-ON INTERVAL
 - 2.8.2.7.2. RELAY SELECTOR
 - 2.8.2.7.3. RUN-ON DURATION
 - 2.8.2.8. PUMP START DELAYS
 - 2.8.2.8.1. DELAY BETWEEN STARTS
 - 2.8.2.8.2. POWER RESUMPTION DELAY
- 2.9. DISCRETE INPUTS
 - 2.9.1. BACKUP LEVEL OVERRIDE
 - 2.9.1.1. TRANSDUCER SELECTOR
 - 2.9.1.2. DISCRETE INPUT NUMBER

- 2.9.1.3. LEVEL OVERRIDE VALUE
- 2.9.1.4. OVERRIDE TIME DELAY
- 2.9.2. DISCRETE INPUT LOGIC
 - 2.9.2.1. DISCRETE INPUT 1
 - 2.9.2.2. DISCRETE INPUT 2
 - 2.9.2.3. DISCRETE INPUT 1 SCALED STATE
 - 3.3.1.4. DISCRETE INPUT 2 SCALED STATE
- 2.10. OTHER CONTROL
 - 2.10.1. EXTERNAL TOTALIZER
 - 2.10.1.1. TRANSDUCER SELECTOR
 - 2.10.1.2. MULTIPLIER
 - 2.10.1.3. RELAY DURATION
 - 2.10.2. EXTERNAL SAMPLER
 - 2.10.2.1. TRANSDUCER SELECTOR
 - 2.10.2.2. MANTISSA
 - 2.10.2.3. EXPONENT
 - 2.10.2.4. RELAY DURATION
 - 2.10.2.5. RELAY SELECTOR
 - 2.10.2.6. RELAY INTERVAL SETPOINT
 - 2.10.3. FLUSH SYSTEM
 - 2.10.3.1. RELAY SELECTOR
 - 2.10.3.2. FLUSH PUMP
 - 2.10.3.3. FLUSH CYCLES
 - 2.10.3.4. FLUSH INTERVAL
 - 2.10.3.5. FLUSH DURATION
- 2.11. SIGNAL PROCESSING
 - 2.11.1. TEMPERATURE AND VELOCITY
 - 2.11.1.1. TRANSDUCER SELECTOR
 - 2.11.1.2. SOUND VELOCITY
 - 2.11.1.3. PROCESS TEMPERATURE
 - 2.11.1.4. TEMPERATURE SOURCE
 - 2.11.1.5. TEMPERATURE TRANSDUCER ALLOCATION
 - 2.11.1.6. FIXED TEMPERATURE
 - 2.11.1.7. SOUND VELOCITY AT 20°C
 - 2.11.1.8. AUTO SOUND VELOCITY
 - 2.11.1.9. OFFSET CORRECTION
 - 2.11.2. ECHO SELECT
 - 2.11.2.1. TRANSDUCER SELECTOR
 - 2.11.2.2. ALGORITHM
 - 2.11.2.3. LONG ECHO THRESHOLD
 - 2.11.2.4. SHORT ECHO THRESHOLD
 - 2.11.2.5. REFORM ECHO
 - 2.11.2.6. NARROW ECHO FILTER
 - 2.11.2.7. SPIKE FILTER
 - 2.11.2.8. SUBMERGENCE DETECTION
 - 2.11.2.9. ECHO MARKER
 - 2.11.2.10. SHORT SHOT BIAS
 - 2.11.2.11. SHORT SHOT FLOOR
 - 2.11.2.12. SHORT SHOT RANGE
 - 2.11.3. TVT SETUP
 - 2.11.3.1. TRANSDUCER SELECTOR
 - 2.11.3.2. AUTO FALSE ECHO SUPPRESSION
 - 2.11.3.3. AUTO SUPPRESSION RANGE
 - 2.11.3.4. HOVER LEVEL
 - 2.11.3.5. SHAPER MODE
 - 2.11.3.6. TVT TYPE

- 2.11.3.7. TVT dB
- 2.11.3.8. TVT MS
- 2.11.3.9. TVT SLOPE MINIMUM
- 2.11.4. TVT SHAPER
 - 2.11.4.1. BRKPT. 1-10
 - 2.11.4.1.1. TVT BRKPT. 1
 - 2.11.4.1.2. TVT BRKPT. 2
 - 2.11.4.1.3. TVT BRKPT. 3
 - 2.11.4.1.4. TVT BRKPT. 4
 - 2.11.4.1.5. TVT BRKPT. 5
 - 2.11.4.1.6. TVT BRKPT. 6
 - 2.11.4.1.7. TVT BRKPT. 7
 - 2.11.4.1.8. TVT BRKPT. 8
 - 2.11.4.1.9. TVT BRKPT. 9
 - 2.11.4.1.10. TVT BRKPT. 10
 - 2.11.4.2. BRKPT. 11-20
 - 2.11.4.2.1. TVT BRKPT. 11
 - 2.11.4.2.2. TVT BRKPT. 12
 - 2.11.4.2.3. TVT BRKPT. 13
 - 2.11.4.2.4. TVT BRKPT. 14
 - 2.11.4.2.5. TVT BRKPT. 15
 - 2.11.4.2.6. TVT BRKPT. 16
 - 2.11.4.2.7. TVT BRKPT. 17
 - 2.11.4.2.8. TVT BRKPT. 18
 - 2.11.4.2.9. TVT BRKPT. 19
 - 2.11.4.2.10. TVT BRKPT. 20
 - 2.11.4.3. BRKPT. 21-30
 - 2.11.4.3.1. TVT BRKPT. 21
 - 2.11.4.3.2. TVT BRKPT. 22
 - 2.11.4.3.3. TVT BRKPT. 23
 - 2.11.4.3.4. TVT BRKPT. 24
 - 2.11.4.3.5. TVT BRKPT. 25
 - 2.11.4.3.6. TVT BRKPT. 26
 - 2.11.4.3.7. TVT BRKPT. 27
 - 2.11.4.3.8. TVT BRKPT. 28
 - 2.11.4.3.9. TVT BRKPT. 29
 - 2.11.4.3.10. TVT BRKPT. 30
 - 2.11.4.4. BRKPT. 31-40
 - 2.11.4.4.1. TVT BRKPT. 31
 - 2.11.4.4.2. TVT BRKPT. 32
 - 2.11.4.4.3. TVT BRKPT. 33
 - 2.11.4.4.4. TVT BRKPT. 34
 - 2.11.4.4.5. TVT BRKPT. 35
 - 2.11.4.4.6. TVT BRKPT. 36
 - 2.11.4.4.7. TVT BRKPT. 37
 - 2.11.4.4.8. TVT BRKPT. 38
 - 2.11.4.4.9. TVT BRKPT. 39
 - 2.11.4.4.10. TVT BRKPT. 40
- 2.11.5. MEASUREMENT VERIFICATION
 - 2.11.5.1. TRANSDUCER SELECTOR
 - 2.11.5.2. UP SAMPLING
 - 2.11.5.3. DOWN SAMPLING
 - 2.11.5.4. ECHO LOCK
 - 2.11.5.5. ECHO LOCK WINDOW
 - 2.11.5.6. FUZZ FILTER

2.12. DISPLAY

2.12.1. LOCAL DISPLAY BACKLIGHT

- 2.12.2. LCD CONTRAST
- 2.12.3. LEVEL SELECTOR
- 2.12.4. DECIMAL POSITION
- 2.12.5. CONVERT READING
- 2.12.6. OFFSET READING
- 2.12.7. DEFAULT AUXILIARY READING
- 2.12.8. DISPLAY DELAY

2.13. FLOW

- 2.13.1. TRANSDUCER SELECTOR
- 2.13.2. PRIMARY MEASURING DEVICE
- 2.13.3. AUTO ZERO HEAD
- 2.13.4. BASIC SETUP
 - 2.13.4.1. FLOW EXPONENT
 - 2.13.4.2. MAXIMUM HEAD
 - 2.13.4.3. MAXIMUM FLOW
 - 2.13.4.4. FLOW TIME UNITS
 - 2.13.4.5. ZERO HEAD
 - 2.13.4.6. FLOWRATE DECIMAL
 - 2.13.4.7. FLOWRATE UNITS
 - 2.13.4.8. LOW FLOW CUTOFF
- 2.13.5. PMD DIMENSIONS
 - 2.13.5.1. OCM DIMENSION 1
 - 2.13.5.2. OCM DIMENSION 2
 - 2.13.5.3. OCM DIMENSION 3
 - 2.13.5.4. OCM DIMENSION 4
 - 2.13.5.5. OCM DIMENSION 5
 - 2.13.5.6. OCM DIMENSION 6
- 2.13.6. UNIVERSAL HEAD VS. FLOW
 - 2.13.6.1. TABLE 1-8
 - 2.13.6.1.1. HEAD 1
 - 2.13.6.1.2. FLOW 1
 - 2.13.6.1.3. HEAD 2
 - 2.13.6.1.4. FLOW 2
 - 2.13.6.1.5. HEAD 3
 - 2.13.6.1.6. FLOW 3
 - 2.13.6.1.7. HEAD 4
 - 2.13.6.1.8. FLOW 4
 - 2.13.6.1.9. HEAD 5
 - 2.13.6.1.10. FLOW 5
 - 2.13.6.1.11. HEAD 6
 - 2.13.6.1.12. FLOW 6
 - 2.13.6.1.13. HEAD 7
 - 2.13.6.1.14. FLOW 7
 - 2.13.6.1.15. HEAD 8
 - 2.13.6.1.16. FLOW 8
 - 2.13.6.2. TABLE 9-16
 - 2.13.6.2.1. HEAD 9
 - 2.13.6.2.2. FLOW 9
 - 2.13.6.2.3. HEAD 10
 - 2.13.6.2.4. FLOW 10
 - 2.13.6.2.5. HEAD 11
 - 2.13.6.2.6. FLOW 11
 - 2.13.6.2.7. HEAD 12
 - 2.13.6.2.8. FLOW 12

- 2.13.6.2.9. HEAD 13
- 2.13.6.2.10. FLOW 13
- 2.13.6.2.11. HEAD 14
- 2.13.6.2.12. FLOW 14
- 2.13.6.2.13. HEAD 15
- 2.13.6.2.14. FLOW 15
- 2.13.6.2.15. HEAD 16
- 2.13.6.2.16. FLOW 16
- 2.13.6.3. TABLE 17-24
 - 2.13.6.3.1. HEAD 17
 - 2.13.6.3.2. FLOW 17
 - 2.13.6.3.3. HEAD 18
 - 2.13.6.3.4. FLOW 18
 - 2.13.6.3.5. HEAD 19
 - 2.13.6.3.6. FLOW 19
 - 2.13.6.3.7. HEAD 20
 - 2.13.6.3.8. FLOW 20
 - 2.13.6.3.9. HEAD 21
 - 2.13.6.3.10. FLOW 21
 - 2.13.6.3.11. HEAD 22
 - 2.13.6.3.12. FLOW 22
 - 2.13.6.3.13. HEAD 23
 - 2.13.6.3.14. FLOW 23
 - 2.13.6.3.15. HEAD 24
 - 2.13.6.3.16. FLOW 24
- 2.13.6.4. TABLE 25-32
 - 2.13.6.4.1. HEAD 25
 - 2.13.6.4.2. FLOW 25
 - 2.13.6.4.3. HEAD 26
 - 2.13.6.4.4. FLOW 26
 - 2.13.6.4.5. HEAD 27
 - 2.13.6.4.6. FLOW 27
 - 2.13.6.4.7. HEAD 28
 - 2.13.6.4.8. FLOW 28
 - 2.13.6.4.9. HEAD 29
 - 2.13.6.4.10. FLOW 29
 - 2.13.6.4.11. HEAD 30
 - 2.13.6.4.12. FLOW 30
 - 2.13.6.4.13. HEAD 31
 - 2.13.6.4.14. FLOW 31
 - 2.13.6.4.15. HEAD 32
 - 2.13.6.4.16. FLOW 32

2.14. TOTALIZERS

- 2.14.1. TRANSDUCER SELECTOR
- 2.14.2. RUNNING TOTALIZER HIGH
- 2.14.3. RUNNING TOTALIZER LOW
- 2.14.4. TOTALIZER DECIMAL POSITION
- 2.14.5. TOTALIZER MULTIPLIER

3. MAINTENANCE AND DIAGNOSTICS

3.1. IDENTIFICATION

- 3.1.1. TAG
- 3.1.2. DESCRIPTOR
- 3.1.3. MESSAGE

- 3.1.4. ORDER NUMBER
- 3.1.5. SERIAL NUMBER
- 3.1.6. HARDWARE REVISION
- 3.1.7. FIRMWARE REVISION
- 3.1.8. LOADER REVISION
- 3.1.9. MANUFACTURE DATE
- 3.1.10. DATE LAST CONFIGURED

3.2. DIAGNOSTICS

- 3.2.1. MASTER RESET
- 3.2.2. POWER-ON RESETS
- 3.2.3. POWER-ON TIME
- 3.2.4. RELAY SELECTOR
- 3.2.5. RELAY LOGIC TEST
- 3.2.6. MEASUREMENT VALUES
 - 3.2.6.1. LEVEL SELECTOR
 - 3.2.6.2. READING
 - 3.2.6.3. LEVEL
 - 3.2.6.4. DISTANCE (%)
 - 3.2.6.5. VOLUME
 - 3.2.6.6. RATE
 - 3.2.6.7. VOLUME RATE
 - 3.2.6.8. READING MAXIMUM
 - 3.2.6.9. READING MINIMUM
 - 3.2.6.10. TRANSDUCER SELECTOR
 - 3.2.6.11. SPACE
 - 3.2.6.12. DISTANCE
 - 3.2.6.13. HEAD
 - 3.2.6.14. FLOW
 - 3.2.6.15. FLOW MAXIMUM
 - 3.2.6.16. FLOW MINIMUM
 - 3.2.6.17. TRANSDUCER TEMPERATURE
 - 3.2.6.18. TS-3 TEMPERATURE
 - 3.2.6.19. MA INPUT
- 3.2.7. PUMP RECORDS
 - 3.2.7.1. RELAY SELECTOR
 - 3.2.7.2. PUMP HOURS
 - 3.2.7.3. PUMP RUN TIME
 - 3.2.7.4. PUMP STARTS
 - 3.2.7.5. PUMP RUN-ONS
- 3.2.8. TEMPERATURE PEAK VALUES
 - 3.2.8.1. TRANSDUCER SELECTOR
 - 3.2.8.2. TRANSDUCER TEMPERATURE MAXIMUM
 - 3.2.8.3. TRANSDUCER TEMPERATURE MINIMUM
 - 3.2.8.4. TS-3 TEMPERATURE MAXIMUM
 - 3.2.8.5. TS-3 TEMPERATURE MINIMUM
- 3.2.9. ECHO QUALITY
 - 3.2.9.1. TRANSDUCER SELECTOR
 - 3.2.9.2. LONG CONFIDENCE
 - 3.2.9.3. SHORT CONFIDENCE
 - 3.2.9.4. ECHO STRENGTH
 - 3.2.9.5. NOISE AVERAGE
 - 3.2.9.6. NOISE PEAK
 - 3.2.9.7. ECHO TIME FILTERED
 - 3.2.9.8. ECHO TIME RAW

3.2.10. SMARTLINX® DIAGNOSTICS

3.2.10.1. HARDWARE STATUS

3.2.10.2. HARDWARE STATUS CODE

3.2.10.3. HARDWARE ERROR COUNT

3.2.10.4. SMARTLINX® MODULE TYPE

3.2.10.5. SMARTLINX® PROTOCOL

3.3. SIMULATION

3.3.1. DISCRETE INPUTS

2.9.2.1. DISCRETE INPUT 1

2.9.2.2. DISCRETE INPUT 2

2.9.2.3. DISCRETE INPUT 1 SCALED STATE

3.3.1.4. DISCRETE INPUT 2 SCALED STATE

4. COMMUNICATION

4.1. COMMUNICATIONS PORT SELECTOR

4.2. DEVICE ADDRESS

4.3. COMMUNICATIONS TIMEOUT

4.4. PROTOCOL

4.5. SERIAL BAUD RATE

4.6. PARITY

4.7. DATA BITS

4.8. STOP BITS

4.9. MODEM AVAILABLE

4.10. MODEM INACTIVITY TIMEOUT

4.11. PARAMETER INDEX LOCATION

4.12. SMARTLINX® RESERVED PARAMETERS (4.12.1. TO 4.12.5.)

5. SECURITY

5.1. WRITE PROTECTION

5.2. USER PIN

5.3. PROTOCOL SELECTOR

5.4. COMMUNICATIONS CONTROL

6. LANGUAGE

* Available only on dual-point models.

** Depends on the choice of Vessel Shape.

*** Depends on the choice of Primary Measuring Device.

**** Displays only if a Service Ratio algorithm is selected for Relay Function.

A

- Accuracy 234
- Alarms 65, 79, 81
 - cable fault 81
 - discrete inputs, triggering alarms 29
 - fail-safe
 - bell trigger 92
 - I/O checkout
 - alarm sounds 115
 - in-bounds 65, 81, 148
 - LCD display
 - level alarm status 28
 - Level 65, 79, 80
 - common parameters 79
 - LOE (loss of echo) 82, 133
 - out-of-bounds 66, 81, 148
 - preset applications 146
 - programming
 - high level alarm 120
 - rake control
 - Level. See also Rake control. 97
 - rate
 - emptying 80
 - filling 80
 - rate of change 66
 - relays
 - alarm contact 150
 - bound alarm setpoints 152
 - cable fault 66
 - fail-safe 134, 152
 - function 65, 67
 - function codes 271
 - In-bounds 65
 - Level 65
 - Loss of Echo (LOE) 66
 - modes of operation 65
 - normal operating conditions, energized 68
 - ON and OFF setpoints 67
 - out-of-bounds 66
 - preset applications 70
 - Rate of Change 66
 - relay status navigation view 67
 - technical data 235
 - temperature 66
 - wiring test, logic test 68

- temperature 66, 81
- Volume 76

Alternate Duty Assist. See Pumps, Relays.

Alternate Duty Backup. See Pumps, Relays.

Altitude 233

Applications

- examples 58
- Flow 59
 - Parshall. See also Flumes. 59
- Level 58
- preset 69

Approvals and certificates 8, 236

Auto False Echo Suppression 170, 240

- troubleshooting 221, 222

B

Backlight. See LCD.

Backup level override 72

Battery 17

- memory battery backup 234

Bit values. See Data types.

C

Cables 21

- cable entry 11
- cable glands, entering through 13
- cable port 16
- co-axial 21
- connecting 19
- entry location 11
- routed through a conduit 12
- safety requirements 9
- transducer 23

Calibration

- parameters 127
 - Auto Sound Velocity 165
 - Offset Correction 166
 - Sound Velocity 163

CE Electromagnetic Compatibility (EMC). See Conformity.

Charts

- approvals and certificates 8
- characterization 77
 - typical flow 112
- common problems 219

- Modbus register map 259
- programming 283
- relay functions 147
- Communications
 - parameters
 - Communications Port Selector 201
 - Serial Baud Rate 202
 - ports, configuring 257
 - SCADA 253
 - SmartLinX® card 18, 235, 253
 - systems 253
 - troubleshooting 217, 224, 273
 - wiring guidelines 255
- Conduit entry 280
- Confidence
 - echo 229, 239
 - LOE 228, 247
 - parameters
 - Algorithm 166, 241
 - Default Auxiliary Reading 179
 - Long Confidence 198
 - Short Confidence 198
 - troubleshooting 221
- Conformity
 - CE Electromagnetic Compatibility 4
 - FCC 4
- Contrast. See LCD.
- D**
- Data types
 - Bit values 268
 - numeric values 268
 - Split values 269
 - Text messages 270
 - Unsigned double precision integer (UIN32) 268
- Decontamination declaration 215
- Dimensions
 - channel 245
 - converging dimension 59, 109
 - Dimension A 44, 142
 - Dimension L 45, 143
 - enclosure
 - mounting 15
 - panel mount 15, 236
 - cutout 14
 - wall mount 11, 236
 - measurement conditions 64
 - OCM 100, 186
 - PMD 51, 100, 186
 - names 186
 - PMD dimensions, troubleshooting 223
 - vessel 243
 - shape and dimensions 76
- Discrete inputs 25, 73
 - application testing 115
 - configuration testing 115
 - feature of HydroRanger 7
 - I/O 260, 261
 - LCD display 29
 - inactive and active 28
 - logic 73
 - parameter 155, 200
 - wiring 73
- Display. See LCD.
- Distance
 - Backup level override. See Backup level override.
 - calculation 241
 - LCD display 31
 - Level application 58
 - parameters
 - Current Output Function 136
 - Default Auxiliary Reading 179
 - Distance 195
 - Empty 128
 - Rate Filter Distance 132
 - Reading 193
 - Relay Dead Band 152
 - Sensor Mode 123
 - Shot/pulse Mode 127
 - Quick Start 38
 - troubleshooting 225
 - units 122
- Dolphin 202
- Dual-point Average (DPA) 123
- Dual-Point Difference (DPD) 123
- Dual-point model
 - average or differential 63
 - calibration 120
 - flush systems 161
 - general discussion 63
 - index types 121
 - outputs 235
 - overview 7
 - pump by rate 89
 - Quick Start Wizards 38–53
 - scanning 243

- sensor mode 61, 123
 - software 79, 83, 85
- Duration
- long shot 125
 - short shot 125
- E**
- Echo 239
- Echo processing 287
- advanced 288
 - algorithm 166
- Empty. See Distance
- parameters. 128
- Enclosure. See also Dimensions, Mounting.
- 236
- Error handling 272
- error codes 276
- F**
- Fail-safe
- advance 135
 - alarm 59, 92
 - application test 116
 - independent controls. See also Alarms, Pumps. 92
 - indexes 64
 - mA Fail-safe Mode 135, 138
 - mA Fail-safe Value 135
 - material level 64
 - mode 67, 134, 247
 - operation 64
 - parameter 133
 - Relay Fail-safe 70, 152
 - timer 64
 - increase value, troubleshooting 228
 - LOE 66, 133
- FCC. See Conformity.
- Firmware
- LCD display 28
 - parameter 191
 - revision history 2
 - updating
 - instructions 277
 - RJ-11 jack connection 254
- First In First Out. See Pumps, Relays.
- Fixed Duty Assist. See Pumps, Relays.
- Fixed Duty Backup. See Pumps, Relays.
- Flow
- application example 59
 - calculation 244
 - flow exponent 50
 - flow time units 53
 - flowrate 50, 53, 184, 187
 - flowrate decimal 52, 184
 - LCD display 30
 - low flow cutoff 53
 - Maximum Flow 52
 - parameters
 - breakpoints 187–189
 - Current Output Function 136
 - Default Auxiliary Reading 179
 - Exponent 160
 - Flow 195
 - Flow Exponent 181
 - Flow Maximum 196
 - Flow Minimum 195
 - Mantissa 159
 - Maximum Flow 182
 - Relay Function 147
 - point data 261
 - Quick Start 47–53
- Flow samplers 59, 98, 99
- parameters
 - Exponent 160
 - Mantissa 159
 - Relay Duration 160
 - Relay Function 147
- Flumes
- BS-3680 / ISO 4359 rectangular 104
 - Cut Throat 111
 - examples
 - Dual Range (nested) Parshall 113
 - trapezoidal 113
 - H-Flume 106
 - Leopold Lagco 110
 - Palmer-Bowlus 105
 - Parshall 109
- Flush device. See Pumps.
- Format register. See SPA.
- Frequency
- long shot 125
 - short shot 125
- H**
- Head 72, 89, 100, 107
- LCD display 30
 - parameters
 - Auto Zero Head 181
 - Current Output Function 136

- Default Auxiliary Reading 179
- Low Flow Cutoff 185
- Maximum Head 182
- Universal Head vs. Flow 186–189
- Zero Head 101, 104, 184
- Parshall Flume 59
- Quick Start 50
 - Low Flow Cutoff 53
 - Maximum Flow 52
 - Maximum Head 51
 - Zero Head 52
- units 122
- universal calculation support 112
- HMI (Human Machine Interface). See LCD.
- Humidity 233
- I**
- Inputs. See also mA inputs. 235
- Installation category. 233
- Installing
 - notes and warnings 9
- L**
- LCD 28
 - backlight 177
 - contrast 178
 - display
 - Auxiliary Reading 29
 - discrete inputs 29
 - field descriptions 29
 - relays 29
 - Measurement Mode 28
 - Multiple readings 30
 - display readout 71
 - parameters
 - Decimal Position 178
 - Totalizer Decimal Position 190
 - technical data
- Level 61–63, 74
 - alarms. See Alarms.
 - application example 58
 - Backup level override. See Backup level override.
 - LCD display 29
 - pumps. See Pumps.
 - Quick Start 37–40
 - system synchronization 23
 - temperature sensor 22
- LOE Timer. See Fail-safe.
- Long shots. See also Frequency, Duration.
- 126
- M**
- mA
 - calibrating 74
 - 20 mA output 75
 - 4 mA output 75
 - inputs 74, 115
 - index types 121
 - technical data 235
 - transducer parameter option 124
 - outputs 74, 115
 - analog 246
 - index types 121
 - technical data 235
 - troubleshooting 223
 - parameters
 - 0/4 mA Level Value 139
 - 20 mA Level Value 139
 - 20 mA Output Trim 138
 - 20 mA Setpoint 137
 - 4 mA Output Trim 138
 - 4 mA Setpoint 137
 - Current Output Function 136, 246
 - mA Damp Filter 139
 - mA Fail-safe Mode 135, 138
 - mA Fail-safe Value 135
 - mA Input 196
 - mA Input Range 139
 - mA Output Selector 135
 - mA Output Allocation 136
 - mA Output Range 136
 - mA Output Selector 136
 - Maximum mA Limit 137
 - Milliamp Output 138
 - Minimum mA Limit 137
 - Raw mA Input Value 140
 - Scaled mA Input Value 139
 - mA inputs and outputs (ma I/O). See also mA. 74
 - Material, types of 124
 - Measurement conditions 63
 - dimensions 64
 - fail-safe indexes 64
 - response rate 64
 - Memory 234
 - Modbus®
 - Application Guide 258
 - communications 7, 202, 253
 - technical data 235

- troubleshooting 273
 - communications control 205
 - device address 202
 - modem inactivity timeout 203
 - parameter index location 204
 - protocol 202
 - setting parameters 254
 - register map 1, 259–260
 - responses 272
 - SIMATIC PDM connection 7, 258
 - steps to
 - reading parameters 274
 - writing parameters 275
- Modes of operation 27
- PROGRAM 27–57
 - edit mode key functions 34
 - editing 33
 - Measurement mode key functions 31
 - navigating 33
 - RUN 27–57
- Mounting
- altitude 233
 - humidity 233
 - installation category 233
 - instructions 11–15
 - locations 10, 233
 - pollution degree 233
 - range 233
 - temperature 233
- N**
- Numeric values. See Data types.
- O**
- OCM (Open Channel Monitoring) 98–99
- common parameters 100
 - current output function 136
 - definitions 100
 - distance calculation 242
 - Exponent 160
 - exponential flow 107
 - external totalizers 98
 - flow calculation 244
 - flow characterization chart 112
 - flow exponent support 107
 - head level 72
 - Mantissa 159
 - multiplier 158
 - OCM Dimension parameters 186
 - point data 261
 - range extension 130
 - reading 193
 - errors and wrong readings 230
 - sensor mode 123
 - sensor offset 129
 - supported applications. See Flumes and Weirs.
 - totalized volume 103
 - zero head 101
- OFF Setpoints. See Relays.
- ON Setpoints. See Relays.
- Outputs. See also mA outputs, Relays, Alarms, and Communications. 235
- P**
- Parameters 117
- format registers 266
 - format words 266
- Index types
- Comm. Port 121
 - Discrete Input 121
 - Echo Profile 121
 - Global 121
 - Level 121
 - mA inputs 121
 - mA outputs 121
 - Relay 121
 - Transducer 121
 - View only 121
- indexing 118, 264
- LCD display 31
- numeric values 268
- parameter
 - Parameter Index Location 203
- Pump Control 122
- Quick Start Flow 122
- Quick Start Level 122
- Quick Start Volume 122
- reading the tables, key terms 117
- reading values 264
 - parameter-specific index method 264
- Sensor 122
- Setup 122
- split values 269
- text messages 270
- types
 - default 70
 - global 70
 - Read only 70
 - reset 71
 - writing 265

- global index method 266
 - parameter-specific index method 266
 - Pollution degree 233
 - Power 24, 233
 - Programming 234
 - alarms 79
 - relays. See Relays.
 - Programming, Program mode. See Modes of operation.
 - Pump Group. See Pumps.
 - Pump Run-ON. See Pumps.
 - Pumps 66, 248
 - control algorithms 248
 - alternate 248
 - Alternate Duty Assist 250
 - Alternate Duty Backup 250
 - First In First Out 252
 - fixed 248
 - Fixed Duty Assist 249
 - Fixed Duty Backup 249
 - service ratio 248
 - Service Ratio Duty Assist 251
 - Service Ratio Duty Backup 252
 - discrete inputs 73
 - Level 66
 - optional controls
 - flush valve 94
 - grouping 94
 - independent fail-safe 92
 - pump start delays 93
 - rate of level change 89
 - relay communications 95
 - Run-ON 92
 - service ratio 90
 - totalizing pumped volume 91
 - wall cling reduction 93
 - other pump controls 252
 - Flush device 252
 - Pump Group 252
 - Pump Run-ON 252
 - Wall cling reduction 252
 - preset applications 69
 - pump by rate 248, 252
 - pump control
 - algorithms 83
 - pump control options 248
 - pump down group 83
 - pump groups 248
 - pumped volume 76
 - relays
 - normal operating conditions, de-energized 68
 - ON and OFF setpoints 67
 - pump up (reservoir) group 84
 - relay status, navigation view 67
 - wiring test, logic test 68
 - usage 95
- ## Q
- Quick Start Wizards 35
 - Flow 47–53
 - Level 37–40
 - Level application parameters 58
 - local commissioning 27
 - parameters 122
 - Primary Reading 29
 - Pump Control 55–57
 - setting via graphical display 35
 - Volume 41–46
- ## R
- Rake control 96
 - Range. See also Mounting. 233
 - Rate 49
 - flowrate 50, 52
 - parameters 130
 - rate alarms 80
 - rate of change 66
 - response rate 40, 44, 49, 64
 - Relays
 - activation 68
 - alarm 65
 - Cable Fault 66
 - In-bounds 65
 - Level 65
 - Loss of Echo (LOE) 66
 - Out-of-bounds 66
 - Rate of Change 66
 - temperature 66
 - Alarm. See Alarms. 65
 - Alternate Duty Assist 84
 - configuring 35
 - Pump Control Wizard 57
 - contacts and connection 22
 - device features 7
 - display field descriptions 29
 - fail-safe
 - adjusting individual relays 70
 - general introduction 65
 - index 36

- LCD display 28
 - local commissioning 27
 - ON setpoints 86, 87
 - optional pump controls. See also Pumps. 89
 - other pump control algorithms 86
 - Alternate Duty Backup 86
 - OFF Setpoints 86
 - ON Setpoints 86
 - First In First Out 88
 - OFF Setpoints 88
 - ON Setpoints 88
 - Fixed Duty Assist 86
 - OFF Setpoints 86
 - ON Setpoints 86
 - Fixed Duty Backup 87
 - OFF Setpoints 87
 - ON Setpoints 87
 - Service Ratio Duty Assist 87
 - OFF Setpoints 87
 - ON Setpoints 87
 - pump down group
 - Alternate Duty Assist 84
 - common parameters 83
 - OFF Setpoints 84
 - ON setpoints 84
 - setting 83
 - pump up
 - Alternate Duty Assist 85
 - OFF Setpoints 85
 - ON Setpoints 85
 - reservoir group
 - common parameters 85
 - setting 84
 - pumps 66
 - Level 66
 - totalizing and sampling 66
 - related parameters 67
 - setpoints 67
 - relay function 55, 56, 65
 - relay logic is modified 68
 - relay selector 55, 56
 - setpoints and functionality 68
 - status in navigation view 67
- Resolution 234
- Response Rate 64
 - liquid splashing, troubleshooting 230
 - parameter 131
 - Quick Start Wizards 40, 44, 49
 - technical reference 246
- RS-232 25
- RS-485 25
- ## S
- SCADA 24, 253
 - mA I/O 74
 - mounting. See Mounting.
 - reading parameters 264
- Screen control. See Rake control. 96
- Sensor
 - mode 123
 - offset 129
- Service Ratio Duty Assist. See Pumps and Relays.
- Service Ratio Duty Backup. See Pumps.
- Short shots. See also Frequency, Duration. 126
- SIMATIC PDM 258
 - accessing Quick Start Wizards 35
 - connection. See also Modbus. 7
 - date last configured 191
 - digital communications 24
 - echo algorithm 230
 - noise problems 226
 - obstructions in the sound beam 229
 - technical data
 - programming 234
 - transducer aiming 228
 - TVT Shaper 173
 - updating software 277
- Single Parameter Access (SPA)
 - error codes. 275
 - format register 275
 - mapping 274
 - reading parameters 274
 - writing parameters 275
- Single-point model
 - flush systems 161
 - general discussion 62
 - index types 121
 - mA output allocation 137
 - outputs 235
 - overview 7
 - pump by rate 89
 - Quick Start Wizards 38–54
 - scanning 243
 - sensor mode 61, 119, 123
- SmartLinx®

- card 235, 253
 - conduit holes 12
 - installation 18
 - mounting the enclosure 15
 - communications
 - DeviceNet 7, 253
 - modules 254
 - PROFIBUS 7, 253
 - diagnostics 199
 - module type 200
 - protocol 200
 - reserved parameters 204
- Software. See Firmware.
- Sound Velocity 242
 - calibration 165
 - parameters
 - Auto Sound Velocity 165
 - Sound Velocity 163
 - Sound Velocity at 20°C 165
- Space
 - Backup level override. See Backup level override.
 - Level application 58
 - parameters
 - Blanking 129
 - Current Output Function 136
 - Default Auxiliary Reading 179
 - Level Override Value 156
 - Reading 193
 - Sensor Mode 123
 - Space 195
 - Units 122
 - Quick Start 38
- Span 127
- Split values. See Data types.
- Symbols
 - safety marking 3
 - used in the manual 1
- Synchronization 23
- ## T
- Temperature 81
 - alarms 66
 - compensation 234
 - error 234
 - fixed 39, 43, 48, 164, 234
 - LCD display 31
 - Modbus register map 260
 - mounting. See also Mounting. 10, 233
 - parameters
 - Default Auxiliary Reading 179
 - Process Temperature 163
 - Temperature and Velocity 162
 - Temperature Peak Values 197
 - Temperature Transducer Allocation 164
 - Transducer Temperature 196
 - Transducer Temperature Maximum 197
 - Transducer Temperature Minimum 197
 - TS-3 Temperature Maximum 197
 - TS-3 Temperature Minimum 198
 - point data 261
 - relay functions 147
 - function codes 271
 - sensor 19–22
 - TS-3 59, 196, 234
 - sound velocity 242
 - source 39, 43, 48, 58, 163, 234
- Terminal board 20
- Text messages. See Data types.
- Totalizers, external 98, 261
 - distance calculation 242
 - Modbus register map 260
 - parameters 117
 - External Totalizer 158
 - Low Flow Cutoff 185
 - Reset Totalizer 191
 - Running Totalizer 189
 - Totalizer 189
 - Totalizer Decimal Position 190
 - Totalizer Multiplier 190
 - relay function code 271
- Transducers
 - aiming 228
 - average or differential 62, 63
 - common chart problems 219–225
 - common wiring problems 227
 - conditions for optimum accuracy 22
 - connecting 21, 278
 - connecting with RG62 co-axial extension 279
 - distance calculation 241
 - Echomax and ST-H 22, 236
 - fixed reading 229
 - frequency 236
 - ignoring bad echo 229

- index types 121
 - installing a transducer with narrower beam 228
 - LOE 228
 - noise problems 226–227
 - nozzle mountings 229
 - obstructions in the sound beam 229
 - parameter
 - indexing 119
 - Siemens transducers connected 124
 - Point data 261
 - scanning 243
 - selector 119, 123
 - Siemens models connected 38, 42, 48
 - sound velocity 242
 - transmit pulse 239
 - wrong reading 230
 - XPS-10, preset to 61, 62
 - XRS-5 59
 - Transmit pulse 239
 - TVT (Time Varying Threshold) 240
 - advanced TVT adjustment 288
 - algorithm 241
 - parameters
 - Shaper Mode 172
 - TVT dB 172
 - TVT ms 173
 - TVT Setup 170
 - TVT Shaper 173–175
 - TVT Slope Minimum 173
 - TVT Type 172
- U**
- Universal calculation
 - support 112
 - Unsigned double precision integer (UINT32).
 - See Data types.
 - Upgrading 278
- V**
- Volume 76–78
 - calculation 243
 - conversion 241
 - dimensions 64
 - flow sampler. See also Flow samplers. 99
 - numeric values 268
 - OCM. See also OCM. 98
 - parameters
 - breakpoints (Table 1-8) 143–145
 - Current Output Function 136
 - Default Auxiliary Reading 179
 - Inflow/discharge Adjust 143
 - Maximum Volume 142
 - Sensor Mode 123
 - Volume 140
 - Volume Rate 196
 - point data 261
 - pumped volume 76, 98, 263
 - totalizing 91
 - totalized 103
 - troubleshooting 223
- W**
- Wall cling
 - adjustment 224
 - reduction 93, 153, 252
 - Weight. See also Enclosure, Mounting. 236
 - Weirs
 - applicable profiles 107
 - BS-3680 / ISO 1438/1 Thin Plate V-Notch weir 103
 - examples
 - Approximate exponential 113
 - Compound 113
 - Contracted rectangular 113
 - Poebing 113
 - non-applicable weir profiles 108
 - standard 107
 - Wet well 83
 - Wiring
 - avoiding common problems 227
 - checking the wiring pin outs 273
 - common problems chart 219–225
 - compartment 16
 - digital communications 24
 - discrete inputs 73
 - electrostatic discharge precautions 3
 - guidelines for communications installation 255
 - I/O checkout test 115
 - insulation 9
 - relay logic 150
 - test 193
 - relay wiring test 68
 - RS-485 254
 - safety during calibration 67
 - transducers 197
 - wiring to a modem 273

For more information

www.siemens.com/level

www.siemens.com/weighing

Siemens Canada Limited
1954 Technology Drive
P.O. Box 4225
Peterborough, ON
Canada K9J 7B1
email: techpubs.smpi@siemens.com

Subject to change without prior notice
A5E36281317 Rev. AA
© Siemens AG 2015



Printed in Canada

www.siemens.com/processautomation